

## BASEPLATE 9519332 Chevrolet Equinox

Pin height - 18"

Center - 22"

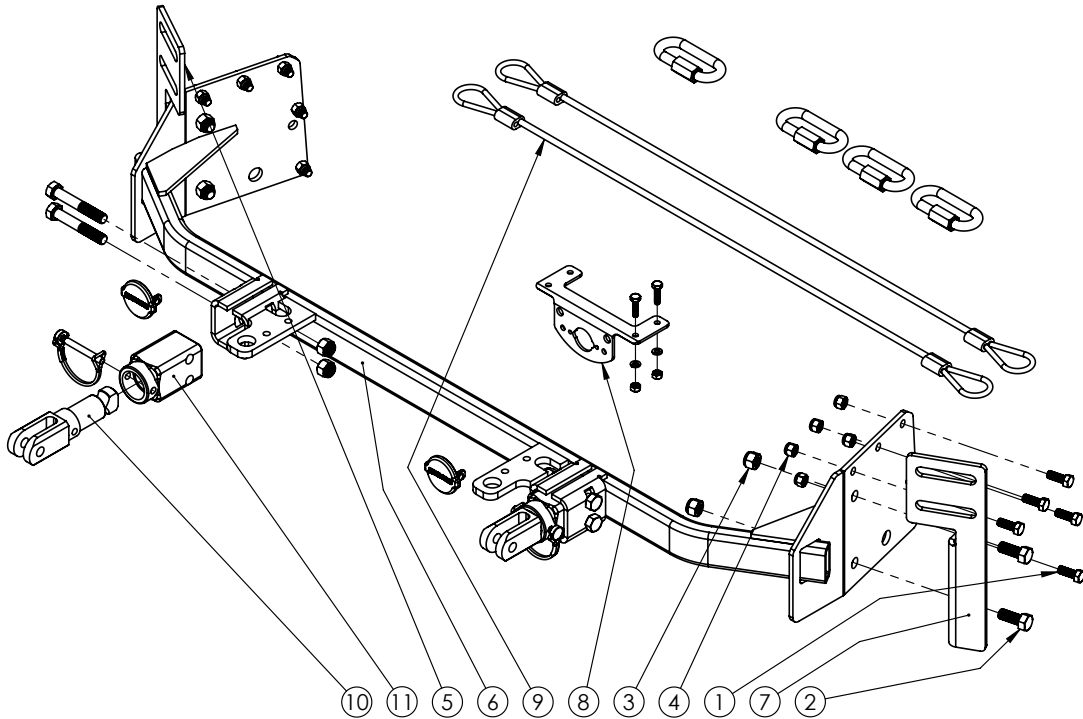

ITEM	PART #	QTY	DESCRIPTION
1	00907	10	BOLT, .375NC X 1.00 HEX HEAD GR.5
2	00967	4	BOLT, .50NC X 1.25
3	02178	4	NUT, .50NC LOCK, NY. INSERT
4	02592	10	NUT, .375NC NYLON LOCK
5	16123-72	1	SUPPORT BRACE PASSENGER F/ 9519332
6	16124-72	1	CROSSMEMBER F/ 9519332
7	16125-72	1	SUPPORT BRACE DRIVER F/ 9519332
8	5937	1	PLUG MOUNT
9	6155	1	BASEPLATE SAFETY CABLE KIT
10	6207	1	TABLESS PULL STUD KIT
11	6208	1	TABLESS PULL BLOCK KIT
-	12329	2	LOCTITE (NOT SHOWN)

Please order replacement parts by PART NO. and DESCRIPTION.

## INTRODUCTION

**WARNING: FAILURE TO FOLLOW THESE INSTRUCTIONS CAN RESULT IN LOSS OF TOWING VEHICLE CONTROL, SEPARATION OF THE TOW BAR FROM THE TOWING VEHICLE, SEPARATION OF THE TOWED VEHICLE FROM THE TOW BAR, CAUSING SEVERE PERSONAL INJURY, DEATH, OR PROPERTY DAMAGE.**

## WARRANTY POLICY, OPERATOR MANUALS & REGISTRATION

Go online to [www.demco-products.com](http://www.demco-products.com) to review Demco warranty policies, operator manuals and register your Demco product.

### CAUTION

Safety is of utmost importance at all times. There are several items that must be checked each time before using and while using a tow bar.

Before allowing anyone to hook up or operate a tow bar, be sure they have read and understand the proper operating procedure.

**DO NOT** use worn or damaged cables and/or pins.

Be sure the **SAFETY CABLES** are hooked, chassis to chassis, to both the towing and towed vehicles using the crisscross method.

Check clearance between vehicles in a turning situation.

Check base plate mounting bolts for tightness and frame for metal fatigue.

Do not load the towed vehicle with anything as you may exceed the towing capacity of the tow bar.

Keep fingers away from pivot points to prevent personal injury.

Be sure the steering components of the towed vehicle are properly aligned.

Demco baseplates are designed for use on factory vehicle suspension setups. Demco baseplates are not recommended for use on modified suspensions lowered or raised. Towing vehicle must be larger and at least 500 lbs. heavier than the towed vehicle and tow bar combined.

**NOTE:** This unit can be backed up in moderate increments. Any severe backwards cornering could result in damage to the Tow Bar and/or towed vehicle chassis.

**For automatic transmissions:** Consult your vehicle owners manual for towing suitability with the drive shaft connected. Otherwise, the towed vehicle will have to be equipped with a transmission pump or drive shaft disconnect.

Check to make sure that all lights are in proper working order.

**The information on towability of vehicles is reprinted with permission of MotorHome® Magazine,** and is believed to be reliable. However, **Demco does not** warrant the information to be correct. Always consult your towed vehicle owner's manual and follow towing instructions. Each year, **MotorHome® Magazine,** compiles a list of vehicles that can be towed four-down behind a motorhome with no modifications required.

 **Caution: MotorHome® Magazine** left out any vehicles that have towing speed limits slower than 55 m.p.h., or distance limits of less than 200 miles. At a minimum, these vehicles require significant modification, such as the use of an aftermarket product, to make them towable. The availability of a **Demco Tow Bar Base Plate** does not imply that these vehicles can be modified or that there is an aftermarket product available. Refer to your vehicle owner's manual or consult your dealer to determine whether your vehicle can be modified to make it towable. Failure to observe this precaution could result in property damage or personal injury.

## IMPORTANT INSTALLATION ITEMS

DEMCO products and accessories are intended to be installed by professional installers with experience, proper equipment and the ability to do modification work. Installers with these qualifications can be found in RV and Automotive Service Centers.

If the car to be towed has been in an accident, the chassis may be damaged in an area where the Base Plate attaches. It may no longer be suitable for towing. Extreme caution and careful examination are required in such a situation. It is also likely, even from a minor accident, that the hole alignment will be more difficult due to hole alignment problems.

Many DEMCO Base Plates are designed to use existing holes and hardware to mount the Base Plate to the towed vehicle. Even though the bolt is there, however, do not assume it is adequate for mounting the Base Plate. Manufacturers make many changes in hardware both within and between model years. Be sure the bolt is long enough to protrude past the nut a distance no less than 1/2 the diameter of the bolt, after the Base Plate is mounted. The threads should be in good condition. **We require that "LOCTITE® Blue" be used on all bolts.** If a new bolt is required, be sure it is SAE Grade 5 or Metric 8.8.

**NOTE: The dimensional variations between otherwise identical vehicles can be considerable. Some minor modifications may have to be made to ensure a proper fit.**

### BOLT TORQUE SPECIFICATIONS

STANDARD BOLTS:			METRIC BOLTS:		
Size	Grade	Torque	Size	Grade	Torque
5/16"	5	18 ft/lbs	8mm	8	23 ft/lbs
3/8"	5	30 ft/lbs	10mm	8	45 ft/lbs
7/16"	5	50 ft/lbs	12mm	8	78 ft/lbs
1/2"	5	75 ft/lbs	14mm	8	125 ft/lbs

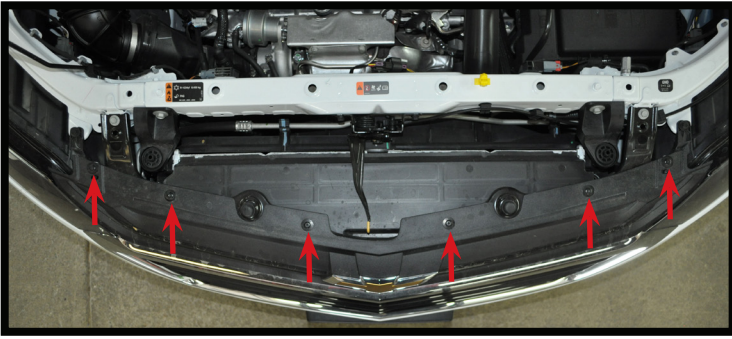

**1.** Using a T15 Torx, remove the six screws from the top edge of the fascia. There are three on each side.

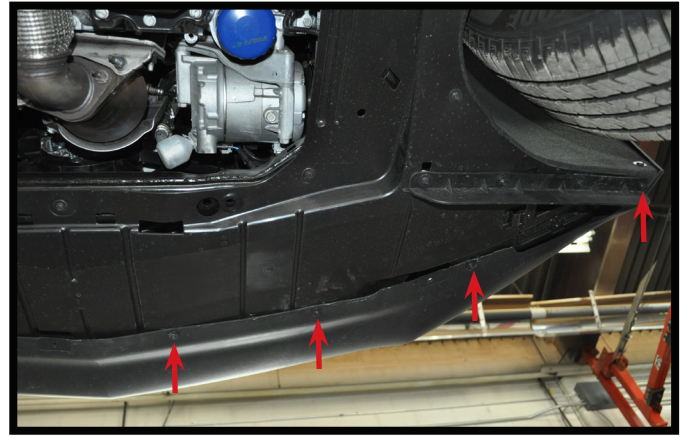

**4.** Using a 7MM socket, remove the eight bolts from the underside of the fascia, four on each side. Remove fascia and set aside to be reinstalled later.

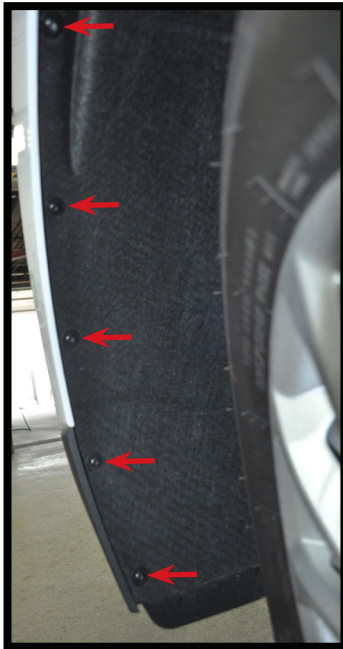

**2.** Using a T15 Torx, remove the five bolts from along the edge of the wheel well. Do this on both sides of the vehicle.



**2022 Models:** Gently pull the fascia as shown in the picture above.

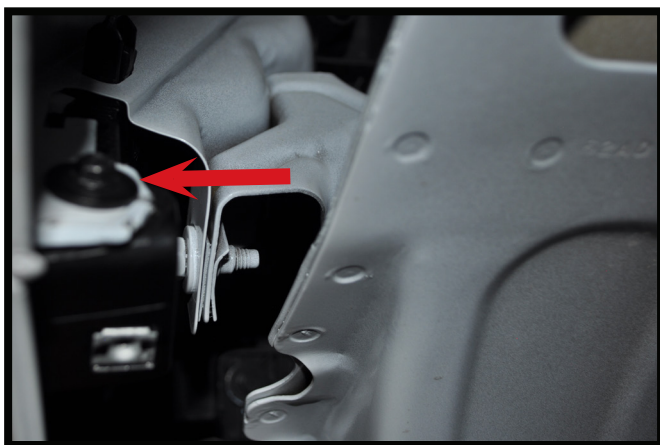

**3.** Using a 7MM socket, remove the bolt from inside the wheel well. Do this for both sides of the vehicle.

**5.** Using a 7MM socket remove the four bolts attaching the driver side head light. Remove and set aside to be reinstalled later.

**6.** Using a 10MM socket, remove all but the upper most bolt and one nut holding the windshield washer reservoir. Tie up the reservoir.

## INSTALLATION

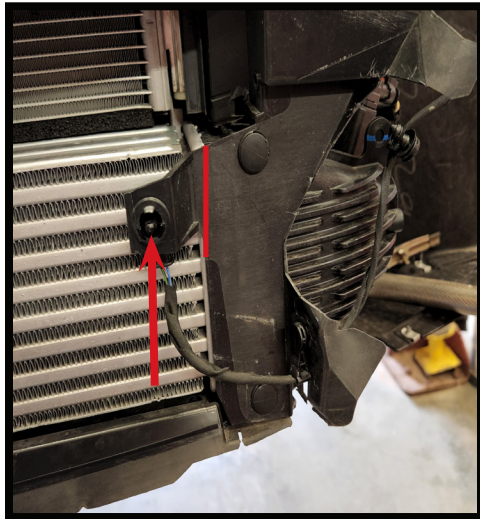
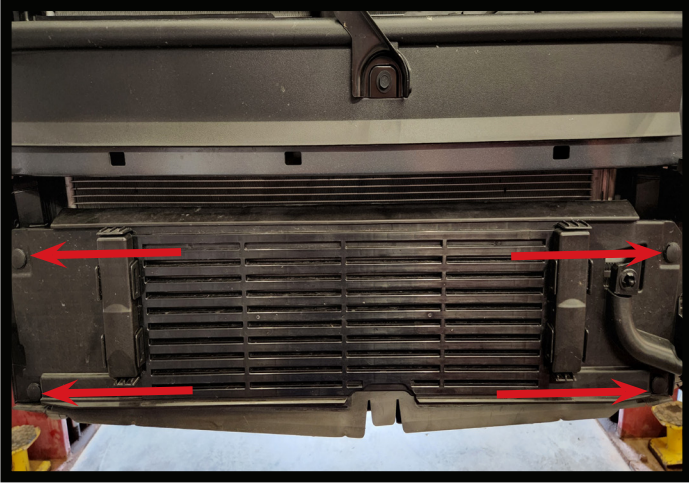

**2022-Present Models:** Remove the lower shutter system by taking out the four plastic push fasteners in the upper picture shown (the lower shutter system will not be reused). This will also take the air dam loose. Reinstall the air dam and place the four plastic push fasteners back in the same spot. Remove and relocate the air temp sensor. Trim the air temp sensor flush as shown above. Trim the plastic air dam as shown on both sides of the vehicle.

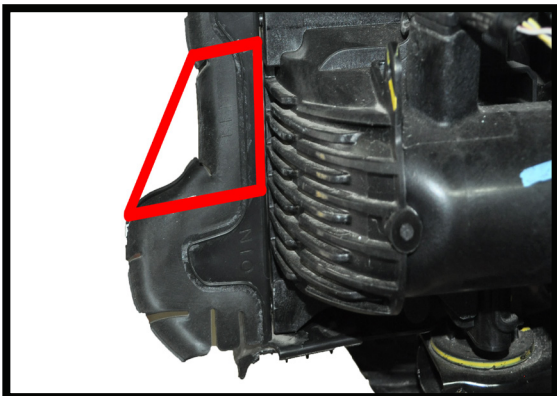

**7.** Cut plastic/rubber air deflector on both ends as shown in picture.

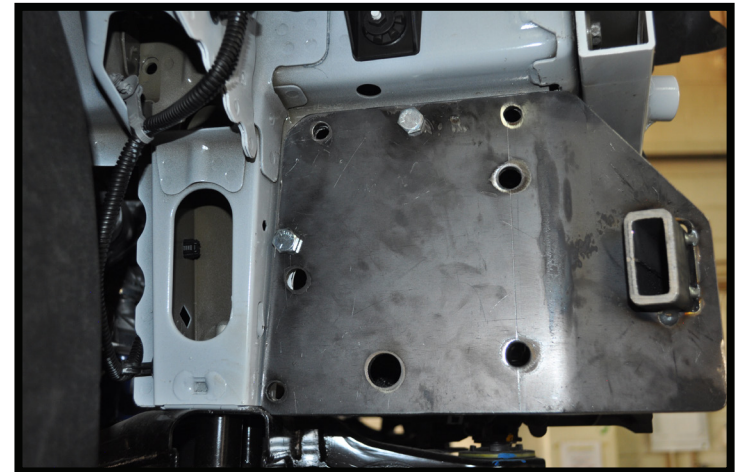
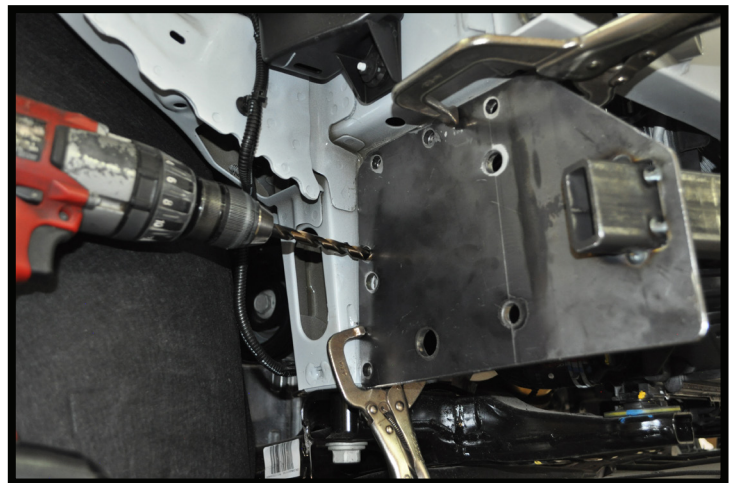

**8.** With an assistant, slide baseplate up into place, tight to the top and tight to the back, clamp two clamps on each side.

**9.** Drill two 3/8 holes on each side, one in the back flange and one in the top flange (see picture). Temporarily tighten with 3/8 x 1" bolts.

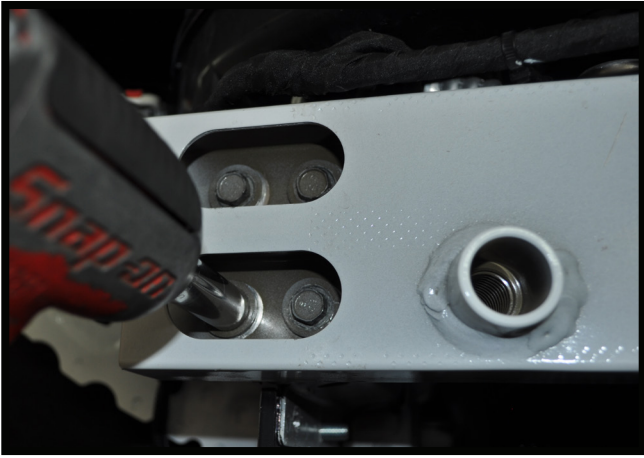

**10.** One side at a time, remove four bolts from bumper to frame.

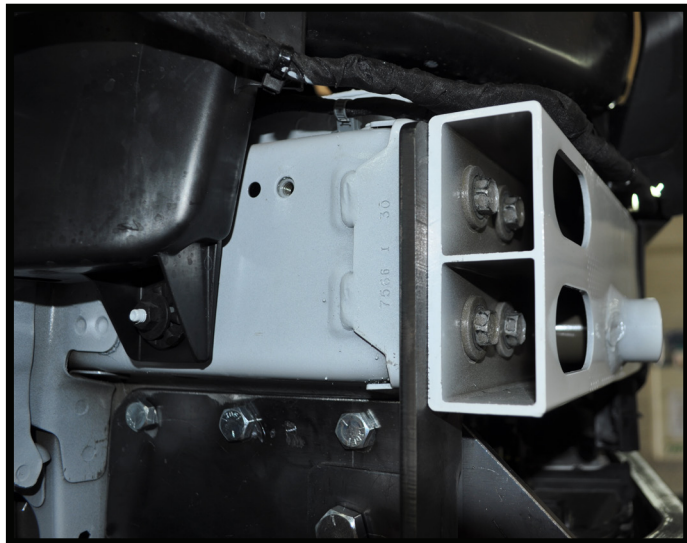
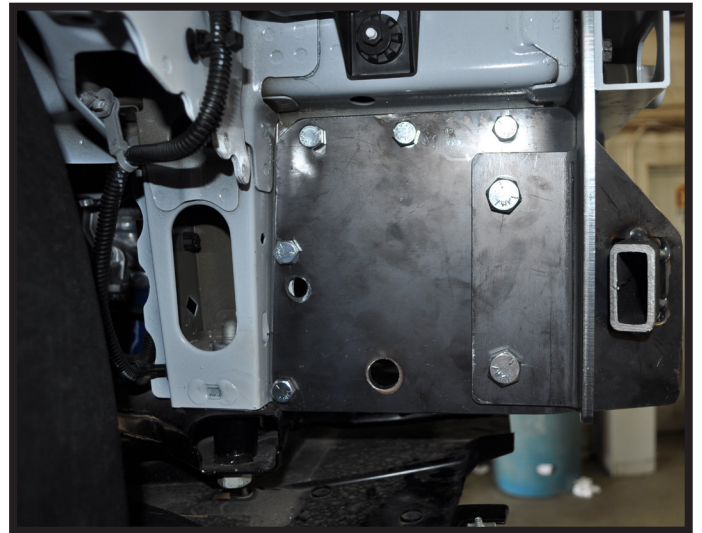
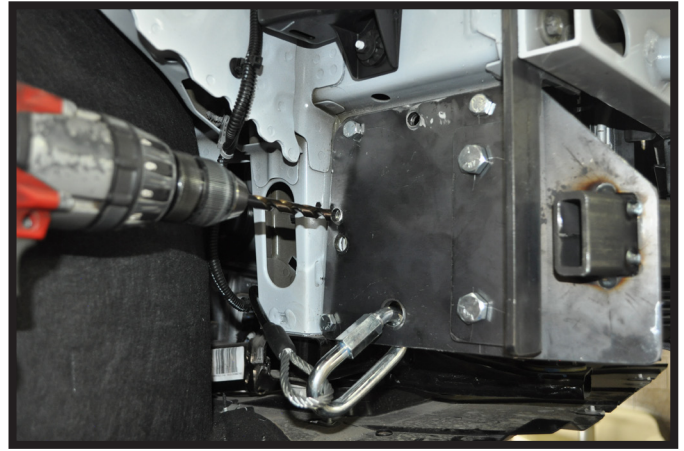

**11.** Pull out slightly and place baseplate Support Brace between bumper and frame. Reinstall bumper bolts through brace and leave loose.

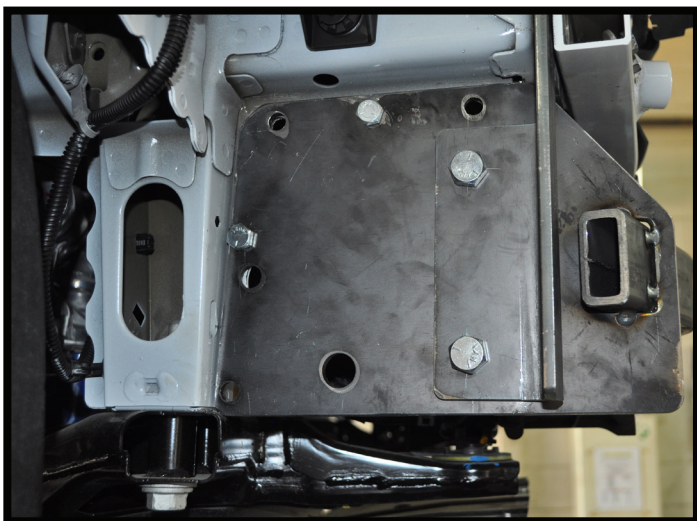

**12.** Install two 1/2 x 1-1/4 bolts, 1/2" lockwashers and 1/2" hex nuts from brace to baseplate. Tighten all previously installed bolts.

**13.** Drill three 3/8 holes on each side of the baseplate. Install 3/8 x 1" bolts and tighten.

## INSTALLATION



**14.** Cut fascia as shown in picture (this picture is taken from the passengers side of the vehicle). Further trimming may be necessary, trim as needed.

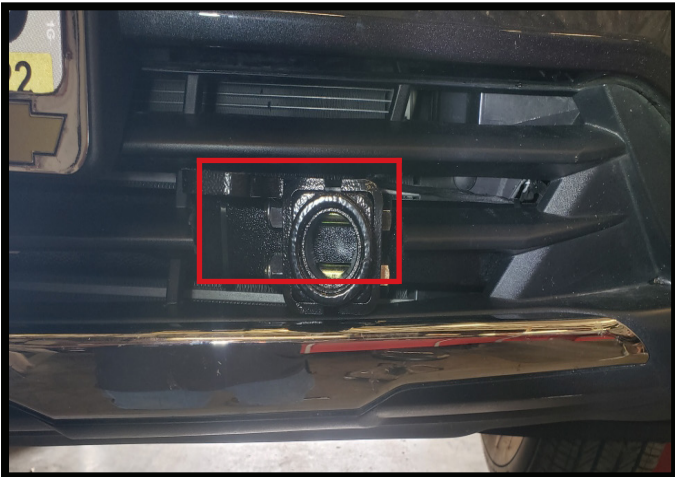

**2022 Models:** Cut fascia as shown in picture (this picture is taken from the drivers side of the vehicle). Further trimming may be necessary, trim as needed.



**15.** Reinstall fascia.



# INSTRUCTIONS

## TOWED VEHICLE BASEPLATE SAFETY CABLES & PARTS BREAKDOWN

### Example #1

Wrap the safety cable around the baseplate crossmember and attach with one quicklink. Attach the other end of the safety cable to the vehicles frame rail or crossmember of the vehicles frame using another quicklink. **See illustration below. NOTE:** when routing cable, make sure cable does not touch or rub against wires, brake hoses, brake lines or axle shafts. Do this on each side of the baseplate.

Baseplate pictured is for illustration only and is not your specific baseplate.

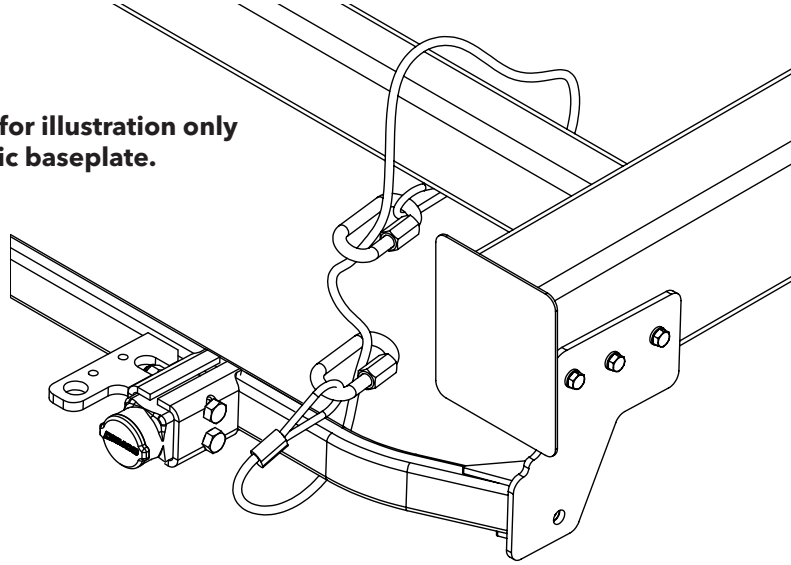

### Example #2

Some baseplate models have a hole to mount the quicklink and cable. Example: some baseplates may not have a crossmember from one side to the other, thus you have a quicklink mounting hole. **See illustration below:** this shows the use of just one quicklink. Other installs may require 2 quicklinks depending on baseplate model. **NOTE:** when routing cable, make sure cable does not touch or rub against wires, brake hoses, brake lines or axle shafts. Do this on each side of the baseplate.

Baseplate pictured is for illustration only and is not your specific baseplate.

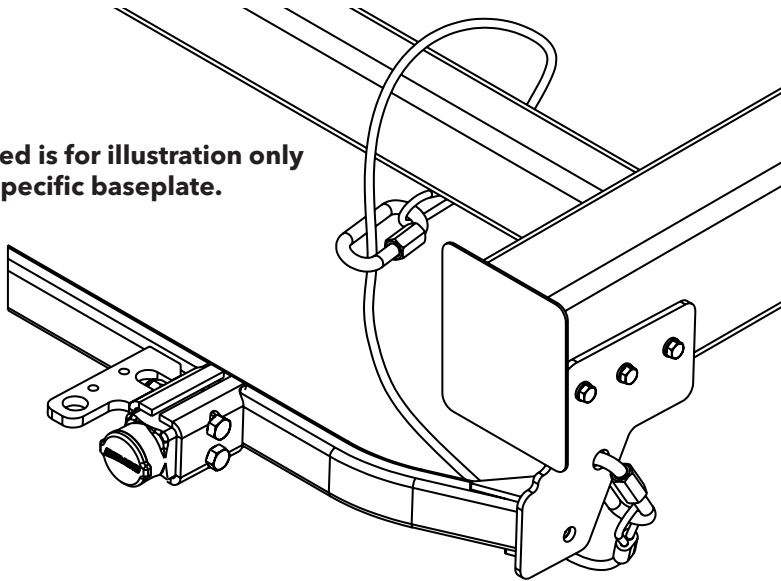

REF. NO.	PART NO.	QTY.	DESCRIPTION
-	6155	-	Safety Cable Kit
1.	-	2	36" Nylon coated safety cables rated @ 14,000 lbs. per pair
2.	-	4	1/2" Quicklinks rated @ 10,000 lbs. each



**Hooking Up Tow Bar to Baseplate**

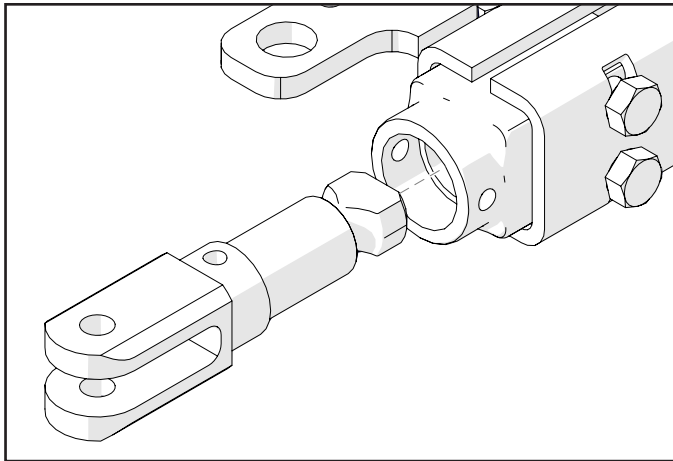

1. Insert pull tab into baseplate pull socket with the flat spot and locking hole facing up. Push pull tab into socket until it stops.

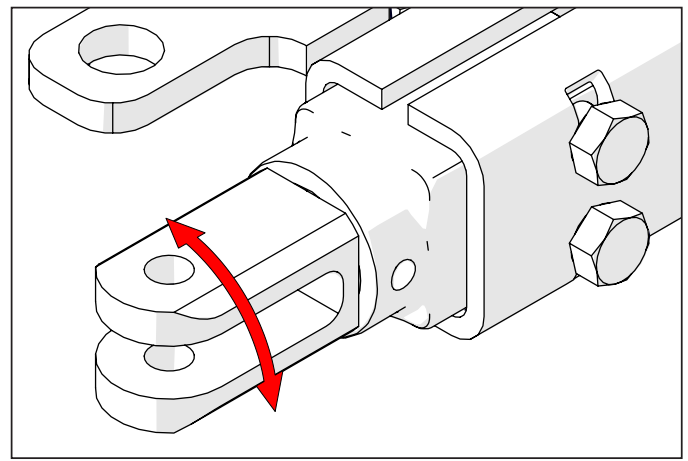

2. Rotate assembly 90° until lock pin holes line up. (Tab to clevis bolt will be horizontal while tow bar to clevis bolt will be vertical).

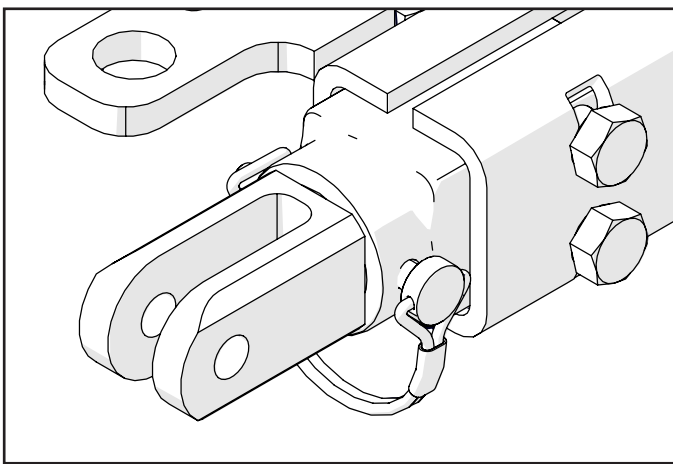

3. Insert locking pin into cross hole. If pin does not install, pull tab may not be installed correctly or try rotating tab 180° and try again. Hook up safety cables and other equipment required for towing your vehicle

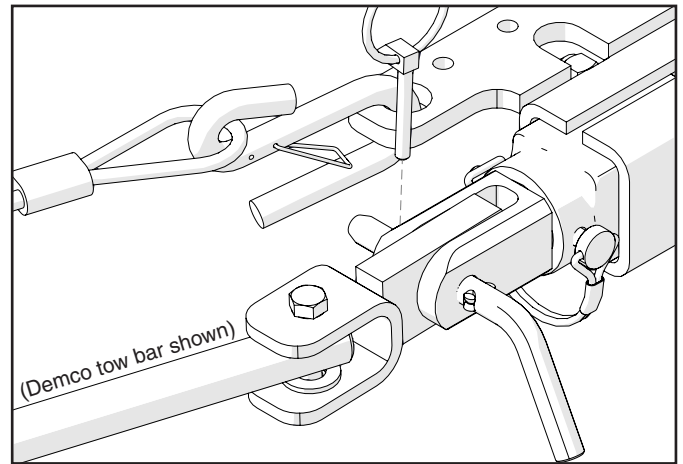

4. Attach tow bar connecting clevis to baseplate's pull tab with clevis pin and lynch pin. Attach safety cables to the chain anchor.

**Unhooking Tow Bar from Baseplate**

1. Release the pressure from tow bar as stated in your tow bar manual.

2. Reverse the hooking up process.

**Plug Cover Instructions**

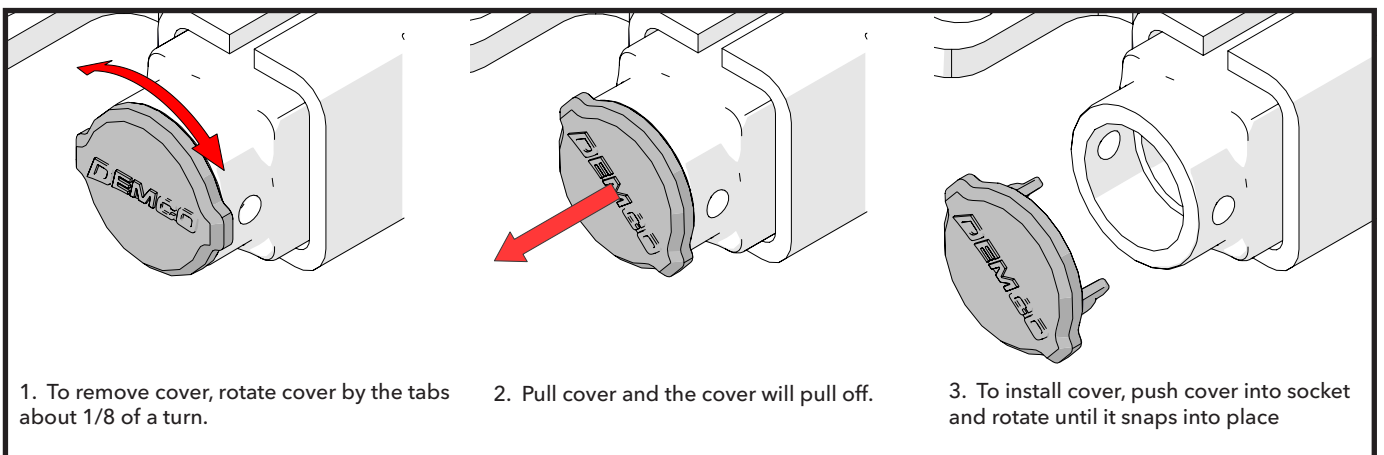

1. To remove cover, rotate cover by the tabs about 1/8 of a turn.

2. Pull cover and the cover will pull off.

3. To install cover, push cover into socket and rotate until it snaps into place





**DEMCO**

4010 320th St., Boyden, IA. 51234

Phone: (712) 725-2311

Fax: (712) 725-2380

Toll Free: 1-800-54DEMCO (1-800-543-3626)

**Demco warranty policies, operator manuals, and product registration  
can be found online:**

**[www.demco-products.com](http://www.demco-products.com)**