

ADAPTOR 9523127 Blue Ox Tow Bar to Demco Tableless Baseplate

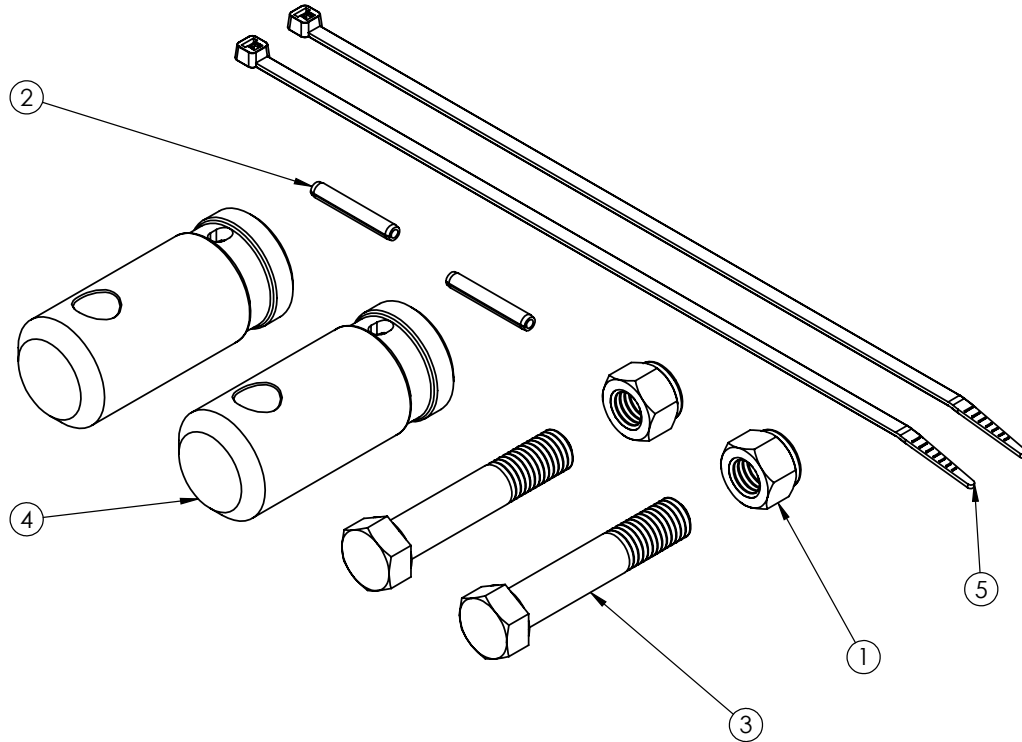

ITEM	PART #	DESCRIPTION	QTY
1	02178	NUT .50NC LOCK NYLON INSERT	2
2	02583	PIN, ROLL .188 X 1.25 ZINC	2
3	15352	BOLT .50NC X 2.75 w/ 1.75 SHANK	2
4	15630-81	BLUE OX TABLESS ADAPTOR	2
5	NHT11	HOSE TIE 11" NYLON	2
6	12329	THREAD LOCK BLUE TUBE (NOT SHOWN)	1

Please order replacement parts by PART NO. and DESCRIPTION



1. Cut plastic tie off of rubber boot on clevis end.



2. Use punch to drive out roll pin.



3. Use a vise grip with a rag or bench vise with rag to hold shaft and use a rod or wrench in the clevis to turn off clevis assembly.



4. Clean the threads and apply some thread lock to threads. Turn on the tableless adapter on shaft until it threads on all the way. Turn off until the hole in shaft lines up with hole in adapter. Drive the new roll pin in hole until flush with adapter.



5. With the hole facing up with tow bar, place the rubber boot over adapter and use the supplied plastic tie to clamp boot to adapter. Cut unused plastic tie.



6. Bolt tableless clevis to adapter making sure not to over tighten, the clevis should rotate freely.

DEMCO

4010 320th St., Boyden, IA. 51234

Phone: (712) 725-2311

Fax: (712) 725-2380

Toll Free: 1-800-54DEMCO (1-800-543-3626)

**Demco warranty policies, operator manuals, and product registration
can be found online:**

www.demco-products.com

