



Doing Our Best to Provide You the Best

HJ26040, Rev 3
07/20

5TH WHEEL SIDE RAIL ASSEMBLIES

#6040 Reese UMS Side Rail

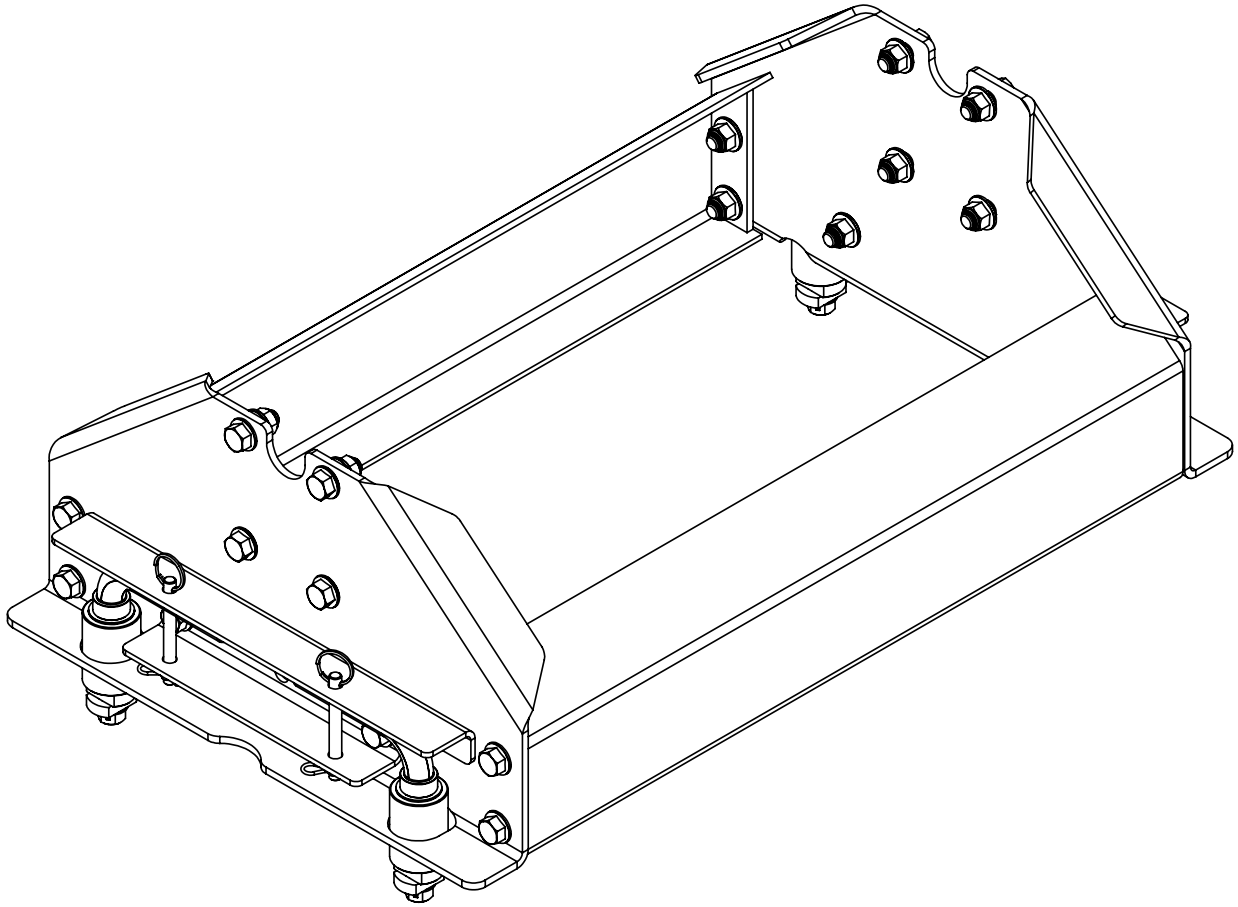

OPERATOR MANUAL

INTRODUCTION

WARRANTY POLICY, OPERATOR MANUALS, PARTS MANUALS & REGISTRATION

Go online to www.demco-products.com to review Demco warranty policies, operator manuals and register your Demco product.



TORQUE SPECIFICATION

Torque figures indicated are valid for non-greased or non-oiled threads and heads unless otherwise specified. Therefore, do not grease or oil bolts or capscrews unless otherwise specified in this manual. When using locking elements, increase torque values by 5%.

* GRADE or CLASS value for bolts and capscrews are identified by their head markings.

BOLT TORQUE DATA FOR STANDARD NUTS, BOLTS, AND CAPSCREWS.

Tighten all bolts to torques specified in chart unless otherwise noted. Check tightness of bolts periodically, using bolt chart as guide. Replace hardware with same grade bolt.

NOTE: Unless otherwise specified, high-strength Grade 5 hex bolts are used throughout assembly of equipment.

Bolt Torque for Standard bolts *						
"A"	GRADE 2		GRADE 5		GRADE 8	
	lb-ft	(N.m)	lb-ft	(N.m)	lb-ft	(N.m)
1/4"	6	(8)	9	(12)	12	(16)
5/16"	10	(13)	18	(25)	25	(35)
3/8"	20	(27)	30	(40)	45	(60)
7/16"	30	(40)	50	(70)	80	(110)
1/2"	45	(60)	75	(100)	115	(155)
9/16"	70	(95)	115	(155)	165	(220)
5/8"	95	(130)	150	(200)	225	(300)
3/4"	165	(225)	290	(390)	400	(540)
7/8"	170	(230)	420	(570)	650	(880)
1"	225	(300)	630	(850)	970	(1310)

Bolt Torque for Metric bolts *						
"A"	CLASS 8.8		CLASS 9.8		CLASS 10.9	
	lb-ft	(N.m)	lb-ft	(N.m)	lb-ft	(N.m)
6	9	(13)	10	(14)	13	(17)
7	15	(21)	18	(24)	21	(29)
8	23	(31)	25	(34)	31	(42)
10	45	(61)	50	(68)	61	(83)
12	78	(106)	88	(118)	106	(144)
14	125	(169)	140	(189)	170	(230)
16	194	(263)	216	(293)	263	(357)
18	268	(363)	--	--	364	(493)
20	378	(513)	--	--	515	(689)
22	516	(699)	--	--	702	(952)
24	654	(886)	--	--	890	(1206)

6040 UMS Side Rail Assembly Instructions

1. Place the side rail plates into the base rail holes in truck box.
2. Loosely bolt the saddle bracket (5990) to the side rails using the 1/2" x 1 1/2" bolts, flat washers, and lock nuts provided in the 6040 bolt package.
3. Loosely bolt the cross braces to the side rails using only 1/2" x 1 1/2" bolts and lock nuts (no flat washers). NOTE: A flat washer under the head of the bolts would prevent the locking pins from pivoting around far enough to allow the pins to release from the base rails.
4. Tighten all the bolts.
5. Unlock and remove the hitch assembly from the base rails and put to the side for later.

IMPORTANT NOTE: Apply a little grease or lubricant to the part of the pins that insert into the base rails to help maintain smooth operation and rotation of pins and to protect from the elements. Turn the pins occasionally to prevent them from seizing.

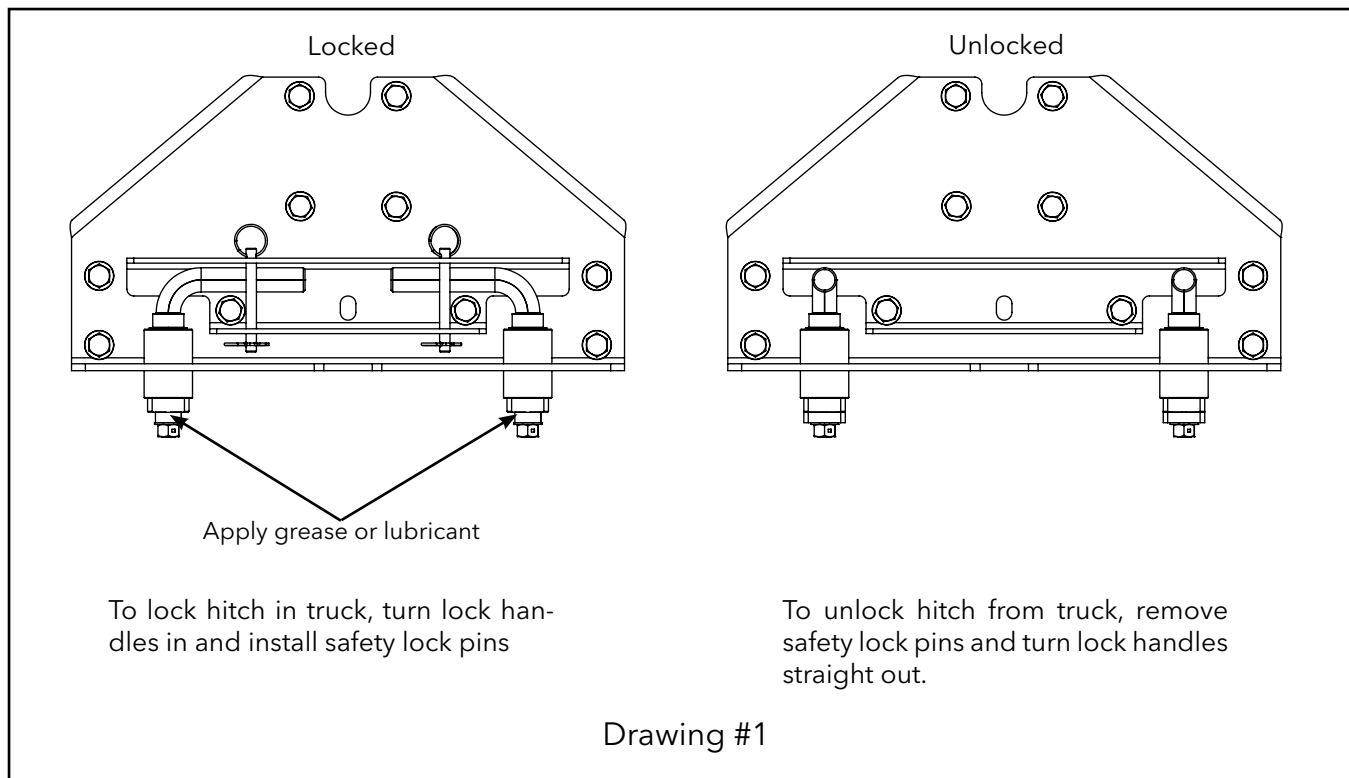

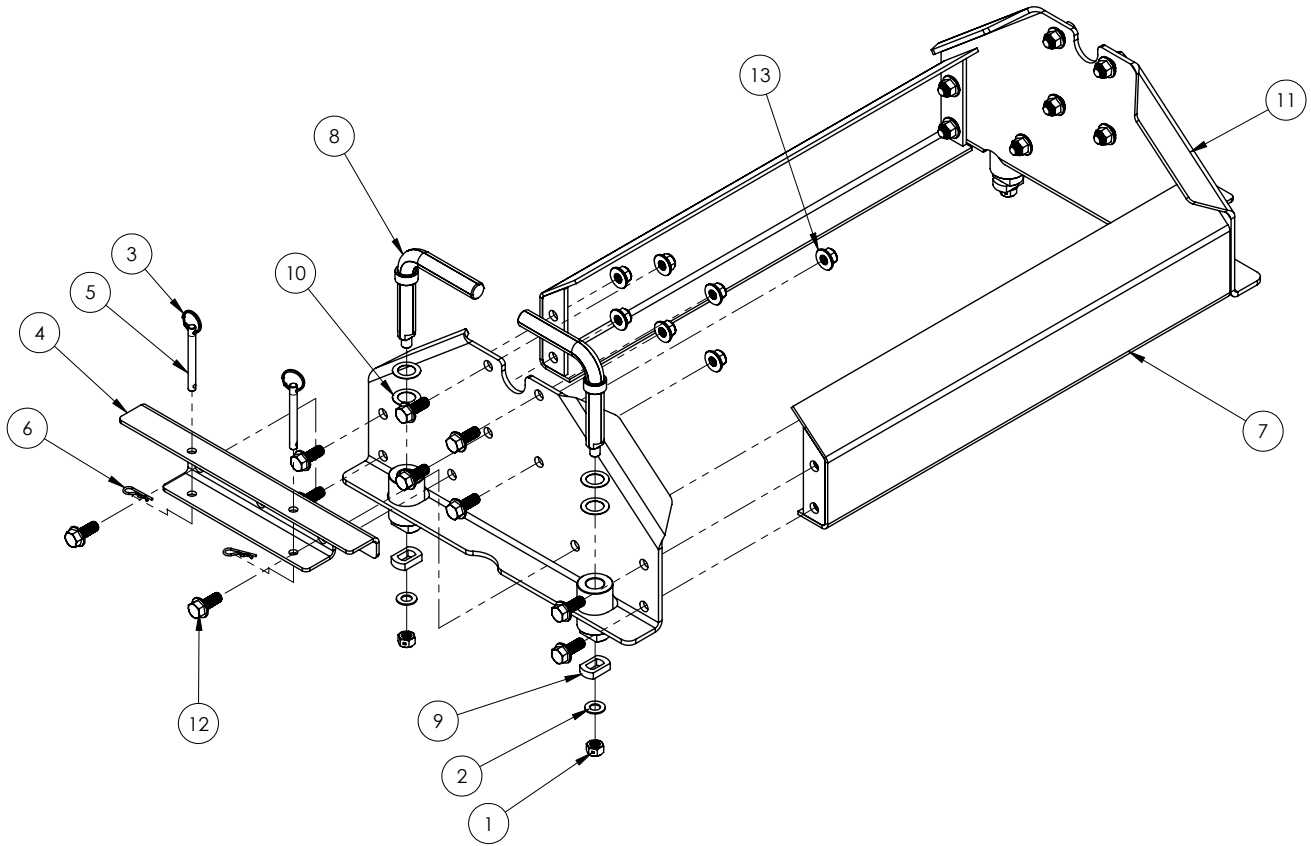

ITEM	PART #	DESCRIPTION	QTY
1	00173	NUT, HEX, .50NC CENTER PUNCH	4
2	02384	.50 X 14GA MACHINE WASHER	4
3	07225	SPLIT RING	4
4	14262-76	UMS SIDE RAIL BRACE	2
5	14342-95	CLEVIS SAFETY PIN	4
6	14350	HAIR PIN, .093 WIRE X 1.63 OL	4
7	14352-76	UMS 21K BRACE	2
8	14412-95	UMS LOCK PIN ASSEMBLY, REESE	4
9	14413-95	LOCKING TAB	4
10	14423	WASHER SHIM .875 ID X .030 THK	8
11	14462-76	SIDE RAIL	2
12	16589	BOLT, .50NC X 1.50 GR5 HEX FLANGE	20
13	16590	NUT, .50NC LOCK NY. INSERT FLANGE	20

Please order replacement parts by PART NO. and DESCRIPTION

DEMCO

4010 320th St., Boyden, IA. 51234

Phone: (712) 725-2311

Fax: (712) 725-2380

Toll Free: 1-800-54DEMCO (1-800-543-3626)

**Demco warranty policies, operator manuals, and product registration
can be found online:**

www.demco-products.com

