



Doing Our Best to Provide You the Best

HJ26026, Rev 1
09/15

5TH WHEEL LOCKING PLATE

6026 - Standard 5th Airborne

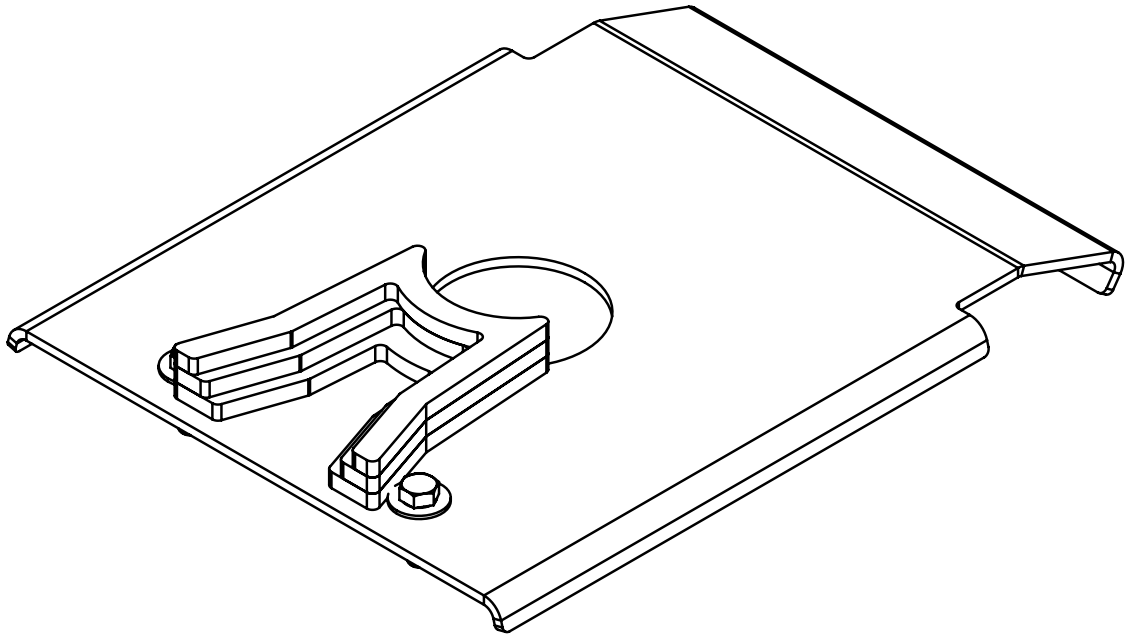

OPERATOR MANUAL

INTRODUCTION

WARRANTY POLICY, OPERATOR MANUALS, PARTS MANUALS & REGISTRATION

Go online to www.demco-products.com to review Demco warranty policies, operator manuals and register your Demco product.



Torque Specifications

BOLT TORQUE DATA FOR STANDARD NUTS, BOLTS, AND CAP-SCREWS.

Tighten all bolts to torques specified in chart unless otherwise noted. Check tightness of bolts periodically, using bolt chart as guide. Replace hardware with same grade bolt.

NOTE: Unless otherwise specified, high-strength Grade 5 hex bolts are used throughout assembly of equipment.

Torque figures indicated are valid for non-greased or non-oiled threads and heads unless otherwise specified. Therefore, do not grease or oil bolts or capscrews unless otherwise specified in this manual. When using locking elements, increase torque values by 5%.

* GRADE or CLASS value for bolts and capscrews are identified by their head markings.

Bolt Torque for Standard bolts *

"A"	GRADE 2		GRADE 5		GRADE 8	
	lb-ft	(N.m)	lb-ft	(N.m)	lb-ft	(N.m)
1/4"	6	(8)	9	(12)	12	(16)
5/16"	10	(13)	18	(25)	25	(35)
3/8"	20	(27)	30	(40)	45	(60)
7/16"	30	(40)	50	(70)	80	(110)
1/2"	45	(60)	75	(100)	115	(155)
9/16"	70	(95)	115	(155)	165	(220)
5/8"	95	(130)	150	(200)	225	(300)
3/4"	165	(225)	290	(390)	400	(540)
7/8"	170	(230)	420	(570)	650	(880)
1"	225	(300)	630	(850)	970	(1310)

Bolt Torque for Metric bolts *

"A"	CLASS 8.8		CLASS 9.8		CLASS 10.9	
	lb-ft	(N.m)	lb-ft	(N.m)	lb-ft	(N.m)
6	9	(13)	10	(14)	13	(17)
7	15	(21)	18	(24)	21	(29)
8	23	(31)	25	(34)	31	(42)
10	45	(61)	50	(68)	61	(83)
12	78	(106)	88	(118)	106	(144)
14	125	(169)	140	(189)	170	(230)
16	194	(263)	216	(293)	263	(357)
18	268	(363)	--	--	364	(493)
20	378	(513)	--	--	515	(689)
22	516	(699)	--	--	702	(952)
24	654	(886)	--	--	890	(1206)

1. Place locking plate up under pin box, inserting the king pin through the hole opening (drawing 1).
2. Once the hole clears the collar on the bottom of the king pin and is even with the 2" diameter middle, pull the locking plate towards the front (drawing 2) so bent lip can clear front bend of pin box plate (drawing 3).
3. Push locking plate back to clear top shoulder of king pin and press up flush against the trailer king pin plate (drawing 4).
4. Fasten to king pin with 3/8" bolts and nuts using existing holes in king pin skid plate at rear. Push bolts with a washer up through the locking plate and have the nut and washer on the inside portion of the king pin box. Tighten securely (drawing 5).
5. Locking plates on hitch head are not needed when using this kit. They can be extended all the way out or removed.

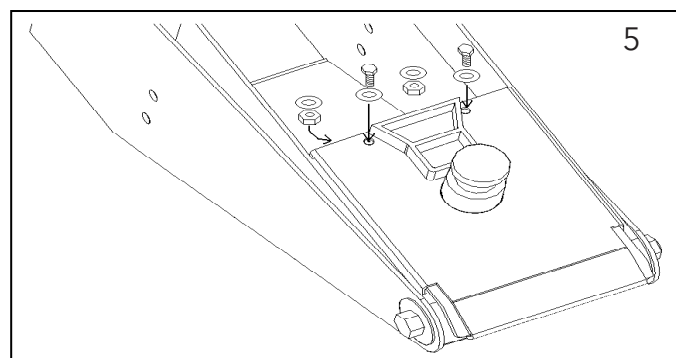
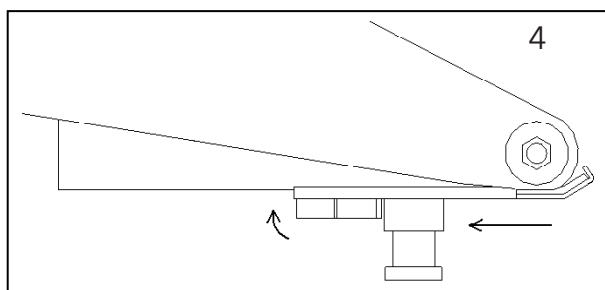
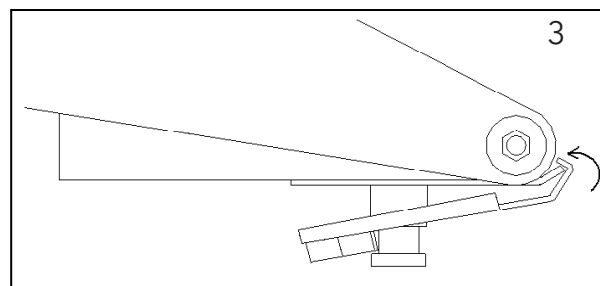
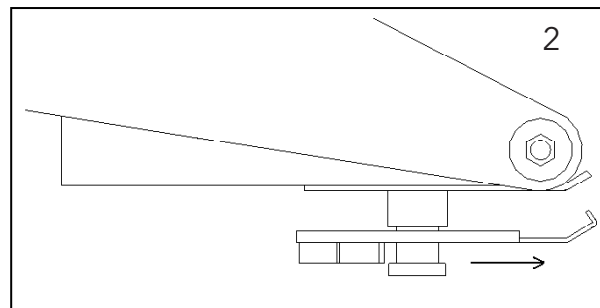
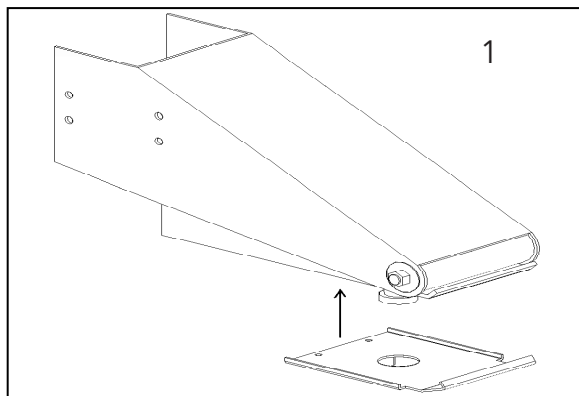

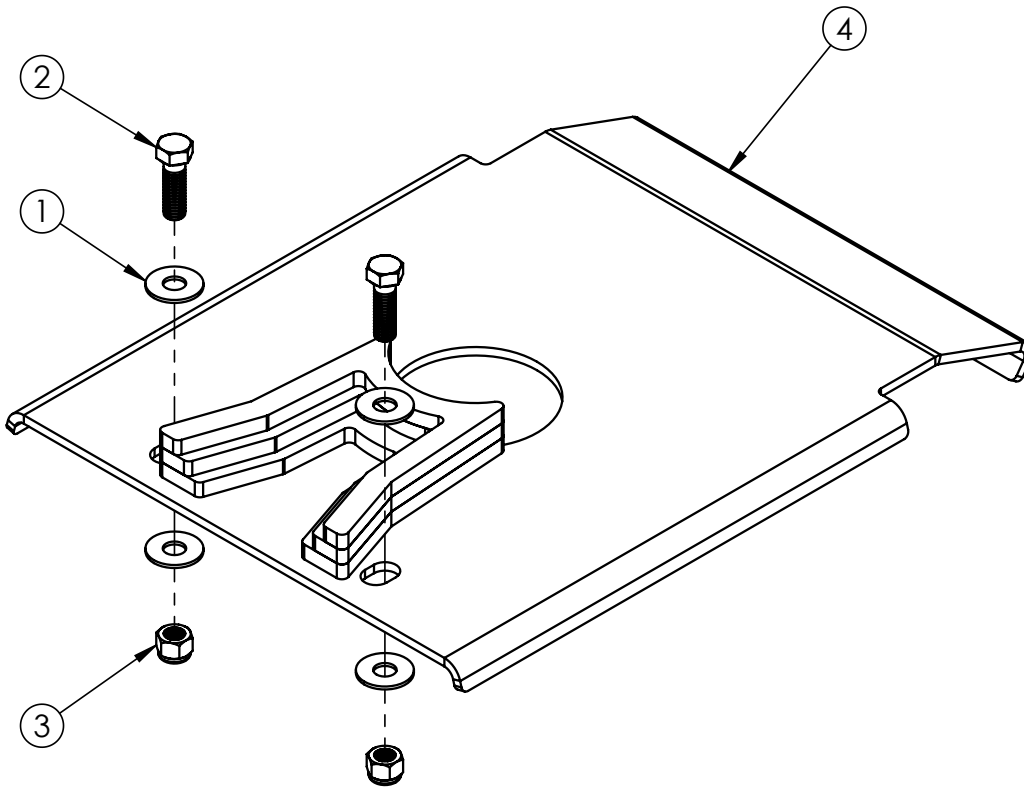

ITEM	PART #	DESCRIPTION	QTY
1	00059	.375 FLAT WASHER	4
2	00523	BOLT, .375NC X 1.25 HEX HEAD GR.5	2
3	02592	NUT, .375NC LOCK NYLON INSERT	2
4	14390-30	LOCKING PLATE	1

Please order replacement parts by PART NO. and DESCRIPTION

DEMCO

4010 320th St., Boyden, IA. 51234

Phone: (712) 725-2311

Fax: (712) 725-2380

Toll Free: 1-800-54DEMCO (1-800-543-3626)

**Demco warranty policies, operator manuals, and product registration
can be found online:**

www.demco-products.com

