



*Doing Our Best to Provide You the Best*

AC20121, Rev 5  
08/24

---

## REAR MOUNT SPRAYERS

### 300, 200 and 150 Gallon

---

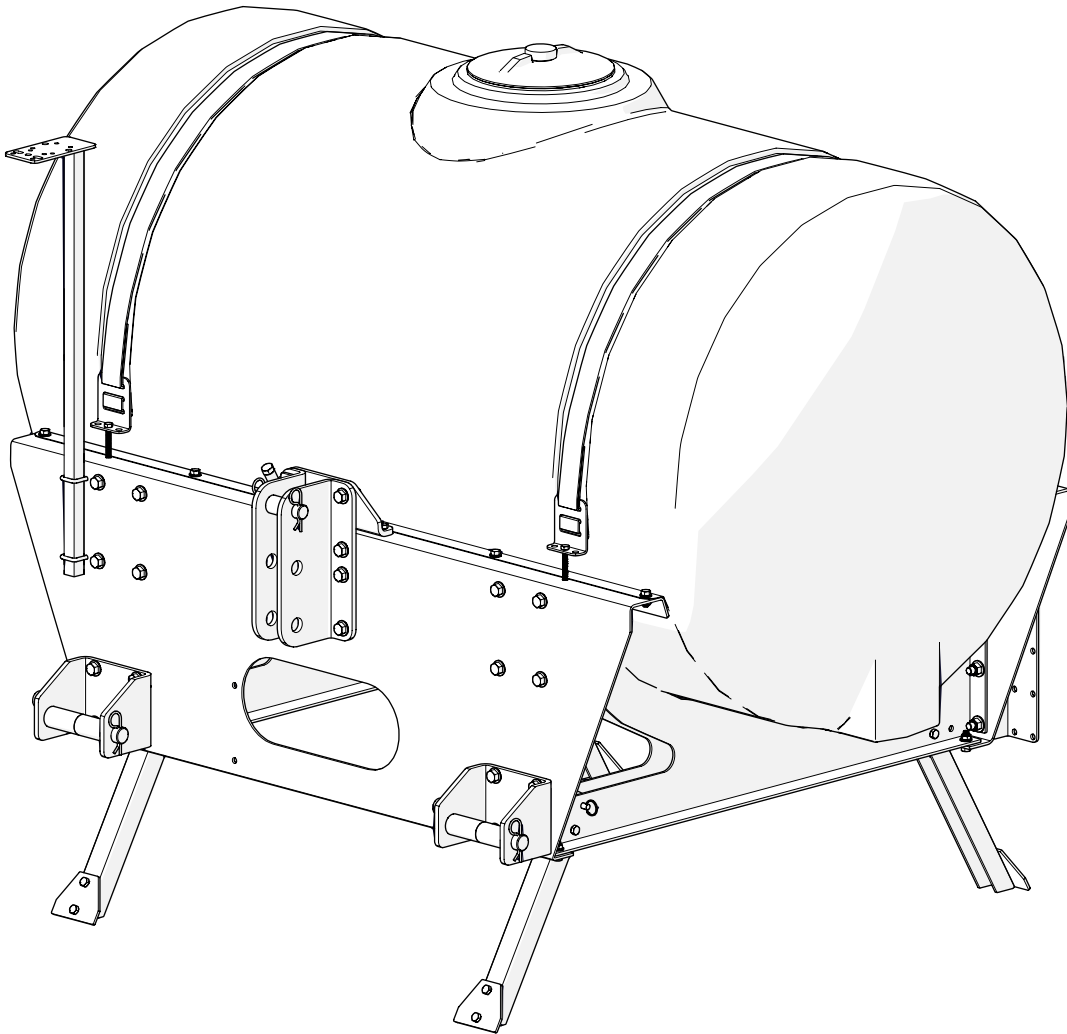

**OPERATOR MANUAL**

## INTRODUCTION

Thank you for purchasing a Demco sprayer. We feel you have made a wise choice and hope you are completely satisfied with your new piece of equipment.

If you have any questions regarding the applications of certain solutions or chemicals, contact your chemical supplier and follow chemical manufacturer recommendations as well as all licensing and use restrictions or regulations.

## WARRANTY POLICY, OPERATOR MANUALS, PARTS MANUALS & REGISTRATION

Go online to [www.demco-products.com](http://www.demco-products.com) to review Demco warranty policies, operator manuals and register your Demco product.



**WARNING: TO AVOID PERSONAL INJURY OR DEATH, OBSERVE FOLLOWING INSTRUCTIONS:**

**Chemicals are dangerous. Know exactly what you're going to do and what is going to happen before attempting to work with these products. Improper selection or use can injure people, animals, plants and soil.**

**Always wear protective clothing such as coveralls, goggles and gloves when working with chemicals or the sprayer.**

**Be sure to dispose of all unused chemicals or solutions in a proper and ecologically sound manner.**

## GENERAL INFORMATION

1. Unless otherwise specified, high-strength (grade5) (3 radial-line head markings) hex head bolts are used throughout assembly of this piece of equipment.
2. Whenever terms "**LEFT**" and "**RIGHT**" are used in this manual it means from a position behind sprayer and facing forward.
3. When placing a parts order, refer to this manual for proper part numbers and place order by **PART NO. and DESCRIPTION.**

## TABLE OF CONTENTS

General Information .....	2
Safety Information .....	3 - 9
Decal Location .....	5
Rear Mount 300 Gallon Breakdown.....	10 - 11
Rear Mount 200/150 Gallon Breakdown .....	12 - 13
Plumbing - Single and Triple Plumbing with Roller Pump .....	14 - 15
Plumbing - Optional Single and Triple Electric Solenoid Controls Parts Breakdown .....	16
Plumbing - Hydraulic Plumbing Parts Breakdown .....	17
Boom Mounting Brackets Installation.....	18
Quick Refill Installation .....	19
Hose Reel Installation.....	20
Bolt Torque .....	22
Sprayer Checklist.....	23

**TAKE NOTE! THIS SAFETY ALERT SYMBOL FOUND THROUGHOUT THIS MANUAL IS USED TO CALL YOUR ATTENTION TO INSTRUCTIONS INVOLVING YOUR PERSONAL SAFETY AND SAFETY OF OTHERS. FAILURE TO FOLLOW THESE INSTRUCTIONS CAN RESULT IN INJURY OR DEATH!**



**THIS SYMBOL MEANS  
ATTENTION  
BECOME ALERT  
YOUR SAFETY IS INVOLVED!**

**SIGNAL WORDS:**

This manual uses the following signal words--**DANGER**, **WARNING**, and **CAUTION**-- with safety messages. The appropriate signal word has been selected using the following guidelines.

**DANGER:**

Indicates an imminently hazardous situation that, if not avoided, will result in death or serious injury. This signal word is to be limited to most extreme situations typically for machine components which, for functional purposes, cannot be guarded.

**WARNING:**

Indicates a potentially hazardous situation that, if not avoided, could result in death or serious injury or death, and includes hazards that are exposed when guards are removed. It may also be used to alert against unsafe practices.

**CAUTION:**

Indicates a potentially hazardous situation that, if not avoided, may result in minor or moderate injury. It may also be used to alert against unsafe practices.

If you have questions not answered in this manual, require additional copies, or if your manual is damaged, please contact your dealer or DEMCO, 4010 320th Street, Boyden, IA 51234  
ph: (712) 725-2311 or Toll Free: 1-800-543-3626 Fax: (712) 725-2380 or 1-800-845-6420  
<http://www.demco-products.com>



## SAFETY...YOU CAN LIVE WITH IT



### EQUIPMENT SAFETY GUIDELINES

Every year many accidents occur which could have been avoided by a few seconds of thought and a more careful approach to handling equipment. You, the operator, can avoid many accidents by observing the following precautions in this section. To avoid personal injury, study the following precautions and insist those working with you, or you yourself, follow them.

In order to provide a better view, certain illustrations in this manual may show an assembly with a safety shield removed. However, equipment should never be operated in this condition. Keep all shields in place. If shield removal becomes necessary for repairs, replace shield prior to use.

Replace any caution, warning, danger or instruction safety decal that is not readable or is missing. Location of such decals is indicated in this booklet.

Do not attempt to operate this sprayer under the influence of alcohol or drugs.

Review safety instructions with all users annually.

Operator should be a responsible adult. **DO NOT ALLOW PERSONS TO OPERATE OR ASSEMBLE THIS UNIT UNTIL THEY HAVE DEVELOPED A THOROUGH UNDERSTANDING OF SAFETY PRECAUTIONS AND HOW IT WORKS.**

To prevent injury or death, use a tractor equipped with a roll over protective system (ROPS). Do not paint over, remove, or deface any safety signs or warning decals on your sprayer. Observe all safety signs and practice instructions on them.

Never exceed limits of a piece of machinery. If its ability to do a job, or to do so safely is in question **DON'T TRY IT.**



### LIGHTING AND MARKING

It is the responsibility of customer to know lighting and marking requirements of local highway authorities and to install and maintain sprayer to provide compliance with regulations. Add extra lights when transporting at night or during periods of limited visibility.

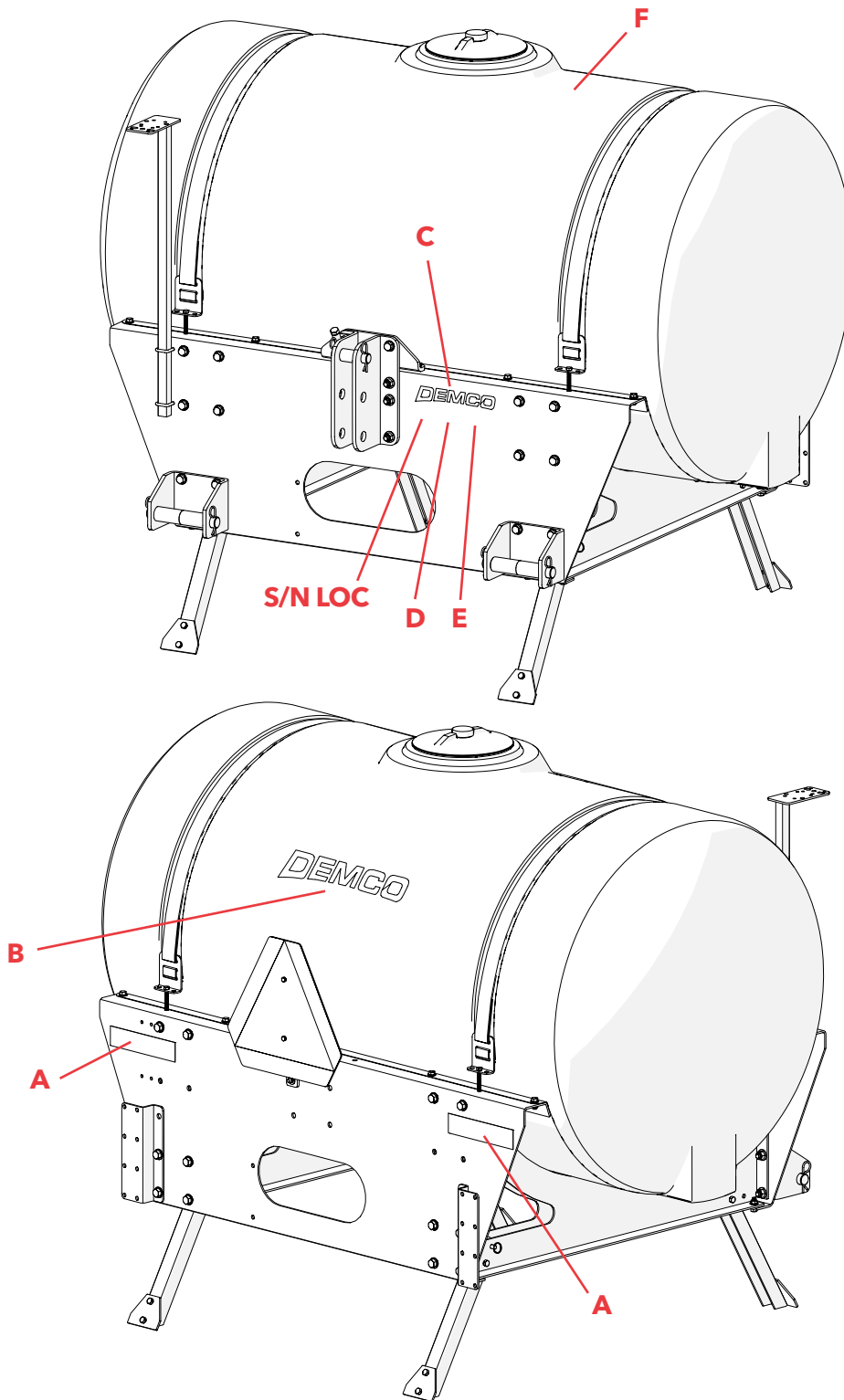

ITEM	PART #	DESCRIPTION	QTY
A	AA21071	DECAL REFLECTOR RED 9 X 2	2
B	AA21076	DECAL DEMCO RED 17 X 3.13	1
C	AA21077	DECAL DEMCO RED 9 X 2	1
D	AB21001	WARNING: DO NOT RIDE....	1
E	AB21002	WARNING: DO NOT STORE....	1
F	AB21014	WARNING: REFER TO CHEMICAL SUPPLIER....	1

Please order replacement parts by PART NO. and DESCRIPTION

## SAFETY SIGN CARE

- Keep safety signs clean and legible at all times.
- Replace safety signs that are missing or have become illegible.
- Replacement parts that displayed a safety sign should also display current sign.
- Safety signs are available from your distributor, dealer parts department, or factory.

### **How to install safety signs:**

- Be sure that installation area is clean and dry.
- Decide on exact position before you remove backing paper.
- Remove smallest portion of split backing paper.
- Align decal over specified area and carefully press small portion with exposed sticky backing in place.
- Slowly peel back remaining paper and carefully smooth decal into place.
- Air pockets can be pierced with a pin and smoothed out using piece of backing paper.

## BEFORE OPERATION

- Carefully study and understand this manual.
- Do not wear loose-fitting clothing which may catch in moving parts.
- Always wear protective clothing and substantial shoes.
- It is recommended that suitable protective hearing and eye protection be worn.
- The operator may come in contact with certain materials which may require specific safety equipment relative to handling of such materials. (Examples: extremely dusty, molds, fungus, bulk fertilizers, etc.)
- Give sprayer a visual inspection for any loose bolts, worn parts, or cracked welds, and make necessary repairs. Follow maintenance safety instructions included in this manual.
- Be sure there are no tools lying on or in equipment
- Do not use sprayer until you are sure that area is clear, especially around children and animals.
- Don't hurry learning process or take sprayer for granted. Ease into it and become familiar with your new equipment.
- Practice operation of your equipment and its attachments. Completely familiarize yourself and other operators with its operation before using.
- Use a tractor equipped with Roll Over Protection System (ROPS) and fasten your seat belt prior to starting engine.
- Manufacturer does not recommend usage of a tractor with ROPS removed.

- Move tractor wheels to widest recommended settings to increase stability.
- Do not allow anyone to stand between tongue or hitch and towing vehicle when backing up to sprayer.



### DURING OPERATION

- Beware of bystanders, **PARTICULARLY CHILDREN!** Always look around to make sure that it is safe to start engine of towing vehicle or move sprayer. This is particularly important with higher noise levels and quiet cabs, as you may not hear people shouting.
- **NO PASSENGERS ALLOWED**- Do not carry passengers anywhere on or in the tractor or sprayer.
- Keep hands and clothing clear of moving parts.
- Do not clean, lubricate, or adjust your sprayer while it is moving.
- When halting operation, even periodically, set tractor or towing vehicles brakes, disengage PTO, shut off engine, and **remove ignition key**.
- Be especially observant of operating area and terrain- watch for holes, rocks, or other hidden hazards. Always inspect area prior to operation.
  - DO NOT operate near edge of drop-offs or banks.
  - DO NOT operate on steep slopes as overturn may result.
  - Operate up and down (not across) intermediate slopes. Avoid sudden starts and stops.
- Pick the most level possible route when transporting across fields. Avoid edges of ditches, gullies, and steep hillsides.
- Be extra careful when working on inclines.
- Periodically clear sprayer of brush, twigs, or other materials to prevent buildup of dry combustible materials.
- Maneuver tractor or towing vehicle at safe speeds.
- Avoid overhead wires. Contact with overhead lines could cause serious injury or death.
- Avoid loose gravel, rocks, and holes; they can be dangerous for sprayer operation or movement.
- Allow for unit length when making turns.
- Do not walk or work under raised components or attachments unless securely supported.
- Keep all bystanders, pets, and livestock clear of work area.
- Never stand alongside of unit with engine running or attempt to start engine and/or operate machine while standing alongside of unit.
- Never leave running equipment attachments unattended.
- As a precaution, always recheck hardware on equipment following every 100 hours of operation. Correct all problems. Follow maintenance safety procedures.



## FOLLOWING OPERATION

- Following operation, or when unhitching, stop tractor or towing vehicle, set brakes, disengage PTO and all power drives, shut off engine and **remove ignition key**.
- Store unit in an area away from human activity.
- Do not park equipment where it will be exposed to livestock for long periods of time. Damage and livestock injury could result.
- Do not permit children to play on or around stored unit.
- Make sure all parked machines are on a hard, level surface and engage all safety devices.



## HIGHWAY AND TRANSPORT OPERATIONS

- **SAFETY CHAINS:** If equipment is going to be transported on a public highway, Always follow state and local regulations regarding safety chains and auxiliary lighting. Be sure to check with local law enforcement agencies for your own particular regulations. If required safety chains should be obtained and installed. Only safety chains (not elastic or nylon/plastic tow straps) should be used to retain connection between towing and towed machines in event of separation of primary attaching system. Use a high strength, appropriately sized hitch pin with a mechanical retainer and attach safety chains. Criss cross chains under tongue and secure to draw bar cage, mounting loops, or bumper frame.
- Adopt safe driving practices:
  - Keep brake pedals latched together at all times. **NEVER USE INDEPENDENT BRAKING WITH MACHINE IN TOW, LOSS OF CONTROL AND/OR UPSET OF UNIT CAN RESULT.**
  - Always drive at a safe speed relative to local conditions and ensure that your speed is low enough for an emergency stop. Keep speed to a minimum.
  - Reduce speed prior to turns to avoid risk of overturning.
  - Always keep tractor or towing vehicle in gear to provide engine braking when going downhill. Do not coast.
  - Do not drink and drive!
- Comply with state and local laws governing highway safety and movement of farm machinery.
- Use approved accessory lighting flags and necessary warning devices to protect operators of other vehicles on highway during transport. Various safety lights and devices are available from your dealer.
- Use of flashing amber lights is acceptable in most localities. However, some localities prohibit their use. Local laws should be checked for all highway lighting and marking requirements.
- When driving a tractor and sprayer under 20 mph (40 kph) day or night, use flashing amber warning lights and a slow moving vehicle (SMV) identification emblem.
- Plan your route to avoid heavy traffic.
- Be a safe and courteous driver. Always yield to oncoming traffic in all situations, including narrow bridges, intersections, etc.
- Be observant of bridge loading ratings. Do not cross bridges rated lower than gross weight at which you are operating.

- Watch for obstructions overhead and side to side while transporting.
- Always operate equipment in a position to provide maximum visibility at all times. Make allowances for increased length and weight of sprayer when making turns, stopping, etc.



## PERFORMING MAINTENANCE

- Good maintenance is your responsibility. Poor maintenance is an invitation to trouble.
- Make sure there is plenty of ventilation. Never operate engine of towing vehicle in a closed building. Exhaust fumes may cause asphyxiation.
- Before working on this machine, stop towing vehicle, set brakes, disengage PTO and all power drives, shut off engine and **remove ignition key**.
- Be certain all moving parts and attachments have come to a complete stop before attempting to perform maintenance.
- Always use a safety support and block wheels. Never use a jack to support machine.
- Always use proper tools or equipment for job at hand.
- Use extreme caution when making adjustments.
- When replacing bolts refer to owners manual.
  - Refer to bolt torque **BOLT TORQUE SPECIFICATIONS** for head identification marking.
  - Follow torque chart in this manual when tightening bolts and nuts.
- Never use your hands to locate a hydraulic leak on attachments. Use a small piece of cardboard or wood. Hydraulic fluid escaping under pressure can penetrate skin.
- Openings in skin and minor cuts are susceptible to infection from hydraulic fluid.  
**Without immediate medical treatment, serious infection and reactions can occur.**
- When disconnecting hydraulic lines, shut off hydraulic supply and relieve all hydraulic pressure.
- Replace **all shields** and **guards** after servicing and before moving.
- After servicing, be sure all tools, parts and service equipment are removed.
- Do not allow grease or oil to build up on any step or platform.
- Where replacement parts are necessary for periodic maintenance and servicing, genuine factory replacement parts must be used to restore your equipment to original specifications. The Manufacturer will not claim responsibility for use of unapproved parts and/or accessories and other damages as a result of their use.
- If equipment has been altered in any way from original design, the manufacturer does not accept any liability for injury or warranty.
- A fire extinguisher and first aid kit should be kept readily accessible while performing maintenance on this equipment



## REMEMBER

Your best assurance against accidents is a careful and responsible operator. If there is any portion of this manual or function you do not understand, contact your local authorized dealer or manufacturer.

# PARTS BREAKDOWN

## REAR MOUNT 300 GALLON PARTS BREAKDOWN

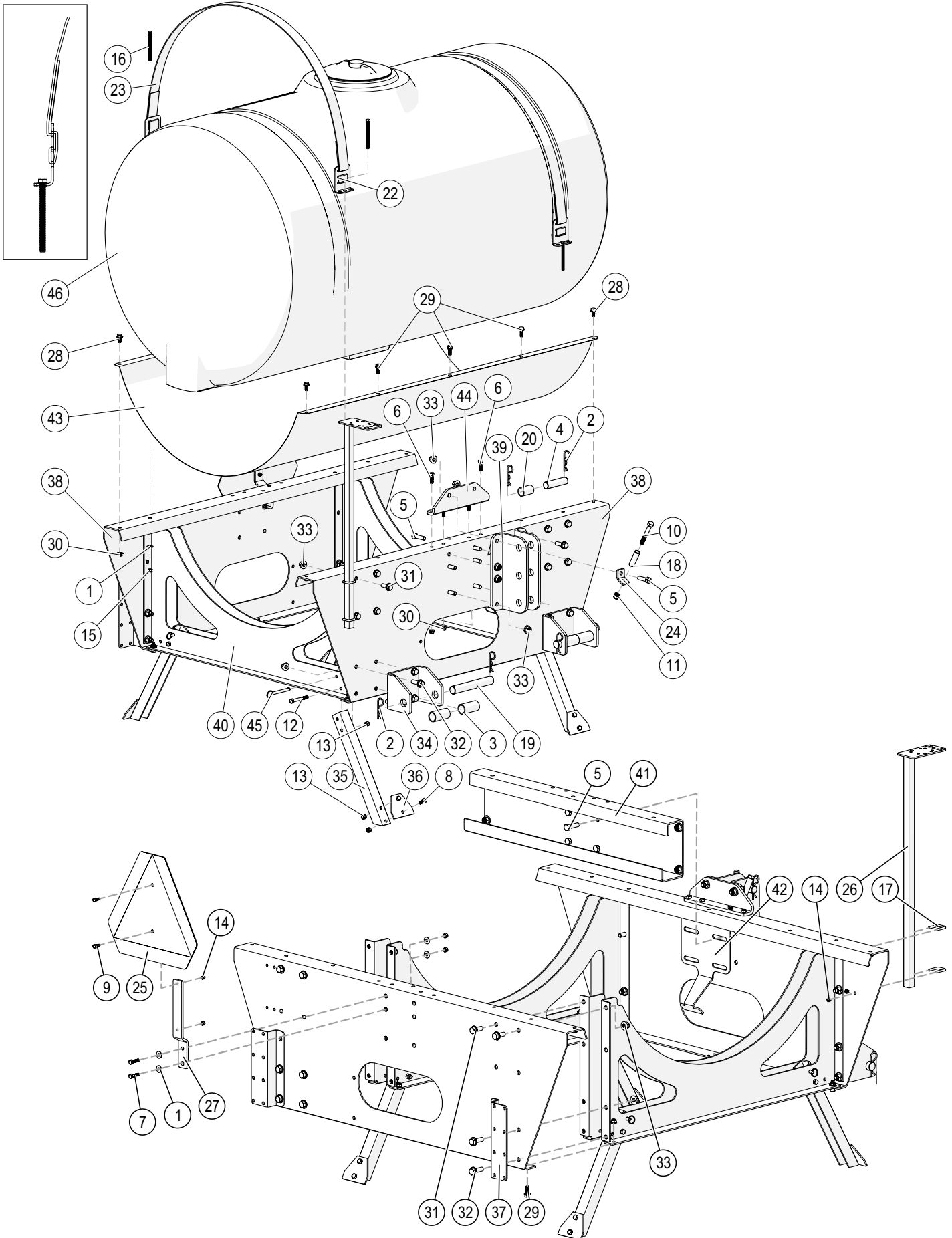

## REAR MOUNT 300 GALLON PARTS BREAKDOWN

ID	ITEM NO	DESCRIPTION	QTY
1	00004	WASHER, FLAT, .313	8
2	00006	HAIR PIN .148 WIRE X 3.06	6
3	00328-95	BUSHING, CATAGORY	4
4	00332-95	PIN, UPPER	1
5	00482	BOLT .50NC X 1.75 GR5 HEX	7
6	00523	BOLT .375NC X 1.25 GR5 HEX	4
7	00685	BOLT .313NC X 1.25 GR5 HEX	2
8	00907	BOLT .375NC X 1.00 GR5 HEX	8
9	01076	BOLT .25NC X .75 GR5 HEX	2
10	01897	BOLT .50NC X 3.50 GR5 HEX	1
11	02178	NUT, .50NC LOCK, NY. INSERT	1
12	02207	BOLT .375NC X 3.00 GR5 HEX	4
13	02592	NUT, .375NC NYLON LOCK	12
14	02772	NUT, .25NC LOCK NYLON INSERT	6
15	02802	NUT, .313 NC NYLON LOCK	6
16	04352	BOLT .313NC X 4.00 GR5 HEX FULL THREAD	4
17	04822	U-BOLT, 1" SQUARE	2
18	05379-95	BUSHING, SPACER	1
19	05382-95	PIN, LOWER	2
20	05383-95	BUSHING, CATAGORY	1
21	05678	U-BOLT, SQ, .313NC X 1.531 X 2.25 (FOR SMV BRKT P.18)	1
22	05785	PLATE, STRAP ANCHOR	4
23	09825	1.75 strap 78"	2
24	11183-95	PUMP MOUNT BRACKET	1
25	12126	SMV SIGN	1
26	12425	VALVE MOUNT	1
27	14952	SMV HOLDER	1
28	16258	BOLT .375NC X .75 GR5 HEX FLG	7
29	16259	BOLT .375NC X 1.00 GR5 HEX FLG	11
30	16260	NUT, .375NC NYLON LOCK FLG	22
31	16588	BOLT .50NC X 1.25 GR5 HEX FLANGE	16
32	16589	BOLT .50NC X 1.50 GR5 HEX FLANGE	13
33	16590	NUT, .50NC LOCK, NY. INSERT FLANGE	36
34	17086	LOWER LINK CHANNEL	2
35	17087	GROUND STAND	4
36	17088	FOOT PLATE	4
37	17089	BOOM MOUNT	2
38	17090	FRONT/REAR PLATE	2
39	17091	UPPER LINK PLATE	2
40	17092	UNDER CHANNEL	4
41	17093	CENTER CHANNEL	1
42	17094	SPACER	1
43	17095	SADDLE PANEL	1
44	17096	GUSSET	1
45	17102	PIN, BALL DETENT .375 X 3.00	4
46	P300 38A	300 GALLON TANK	1

Please order replacement parts by PART NO. and DESCRIPTION.

# PARTS BREAKDOWN

## REAR MOUNT 200 AND 150 GALLON PARTS BREAKDOWN

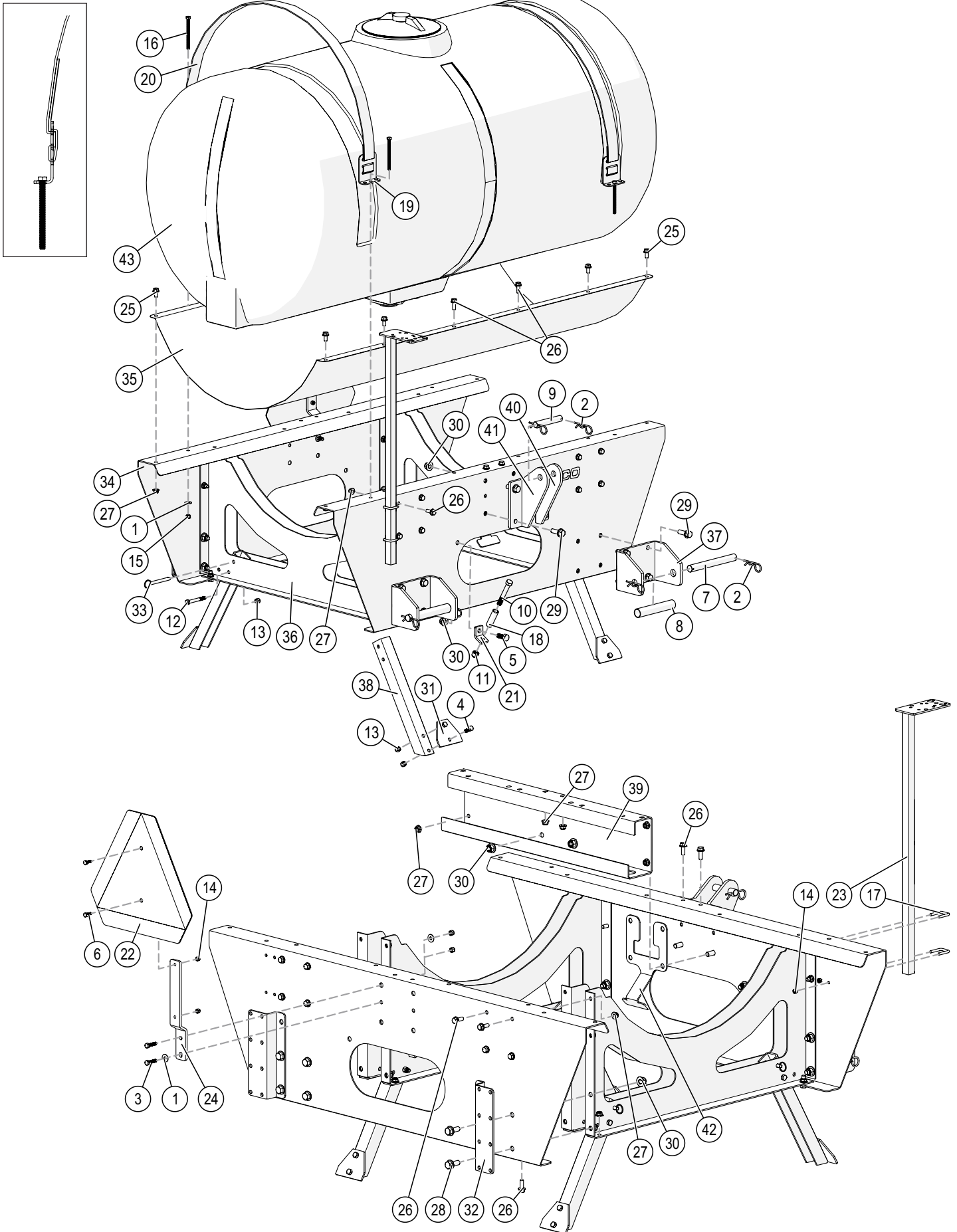

## REAR MOUNT 200 AND 150 GALLON PARTS BREAKDOWN

ID	ITEM NO	DESCRIPTION	QTY
1	00004	WASHER, FLAT, .313	6
2	00006	HAIR PIN .148 WIRE X 3.06	6
3	00685	BOLT .313NC X 1.25 GR5 HEX	2
4	00907	BOLT .375NC X 1.00 GR5 HEX	8
5	00967	BOLT .50NC X 1.25 GR5 HEX	1
6	01076	BOLT .25NC X .75 GR5 HEX	2
7	01121-95	RM BOTTOM PIN	2
8	01122-95	RM CATEGORY SPACER	2
9	01123-95	RM TOP PIN	1
10	01897	BOLT .50NC X 3.50 GR5 HEX	1
11	02178	NUT, .50NC LOCK, NY. INSERT	1
12	02207	BOLT .375NC X 3.00 GR5 HEX	4
13	02592	NUT, .375NC NYLON LOCK	12
14	02772	NUT, .25NC LOCK NYLON INSERT	6
15	02802	NUT, .313 NC NYLON LOCK	6
16	04352	BOLT .313NC X 4.00 GR5 HEX FULL THREAD	4
17	04822	U-BOLT, 1" SQUARE	2
18	05379-95	BUSHING, SPACER	1
19	05785-95	PLATE, STRAP ANCHOR	4
20	09821	1.75" POLY STRAP 64"	2
21	11183-95	PUMP MOUNT BRACKET	1
22	12126	SMV SIGN	1
23	12425	VALVE MOUNT	1
24	14952	SMV HOLDER	1
25	16258	BOLT .375NC X .75 GR5 HEX FLG	10
26	16259	BOLT .375NC X 1.00 GR5 HEX FLG	28
27	16260	NUT, .375NC NYLON LOCK FLG	38
28	16588	BOLT .50NC X 1.25 GR5 HEX FLANGE	8
29	16589	BOLT .50NC X 1.50 GR5 HEX FLANGE	12
30	16590	NUT, .50NC LOCK, NY. INSERT FLANGE	21
31	17088	FOOT PLATE	4
32	17089	BOOM MOUNT	2
33	17102	PIN, BALL DETENT .375 X 3.00	4
34	17210	FRONT/REAR PLATE RM200	2
-	17208	FRONT/REAR PLATE RM150	2
35	17211	SADDLE PANEL 59" 200G	1
-	17209	SADDLE PANEL 42" 150G	1
36	17212	UNDER CHANNEL RM150/200	4
37	17213	LOWER LINK CHANNEL RM150/200	2
38	17214	GROUND STAND SHORT	4
39	17215	CENTER CHANNEL	1
40	17216	UPPER LINK PLATE LEFT RM150/200	1
41	17217	UPPER LINK PLATE RIGHT RM150/200	1
42	17218	SPACER PLATE RM150/200	1
43	P200 32A	200 GALLON RMU TANK	1
-	P150 32A	150 GALLON RMU TANK	1

Please order replacement parts by PART NO. and DESCRIPTION.

# PLUMBING

## SINGLE AND TRIPLE SECTION PLUMBING FOR REAR MOUNT W/ ROLLER PUMP

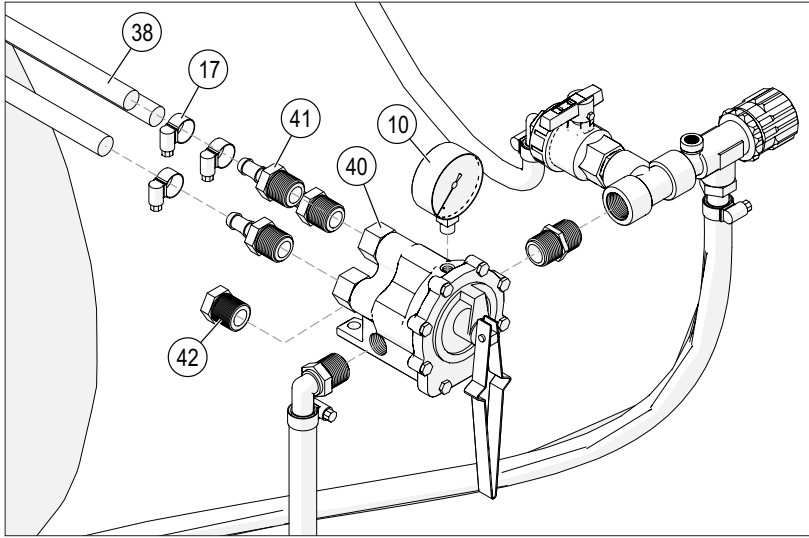

**TRIPLE SECTION PLUMBING**

**OPTIONAL HAND GUN - DBHGR**

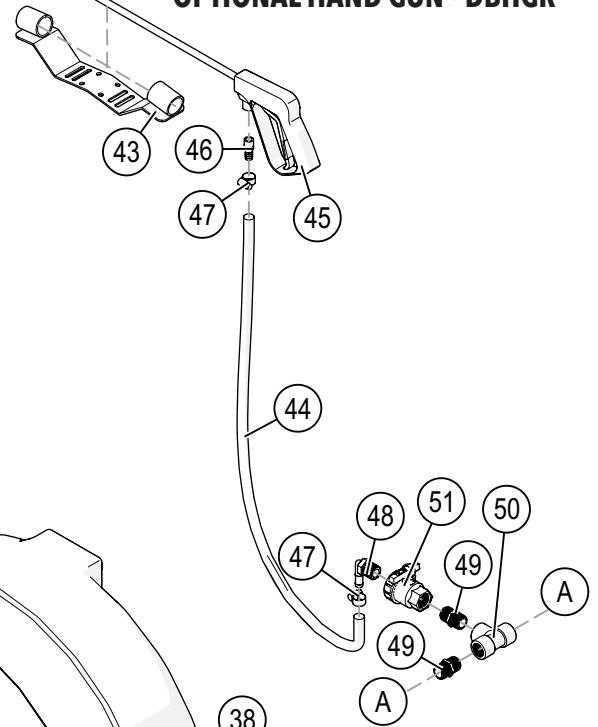

**NOTE:**  
USE THREAD SEALANT ON  
ALL THREADED FITTINGS.

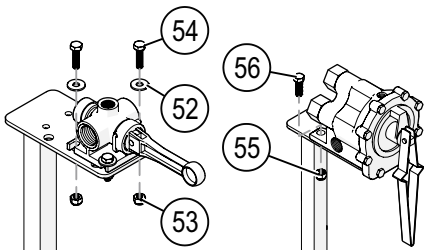
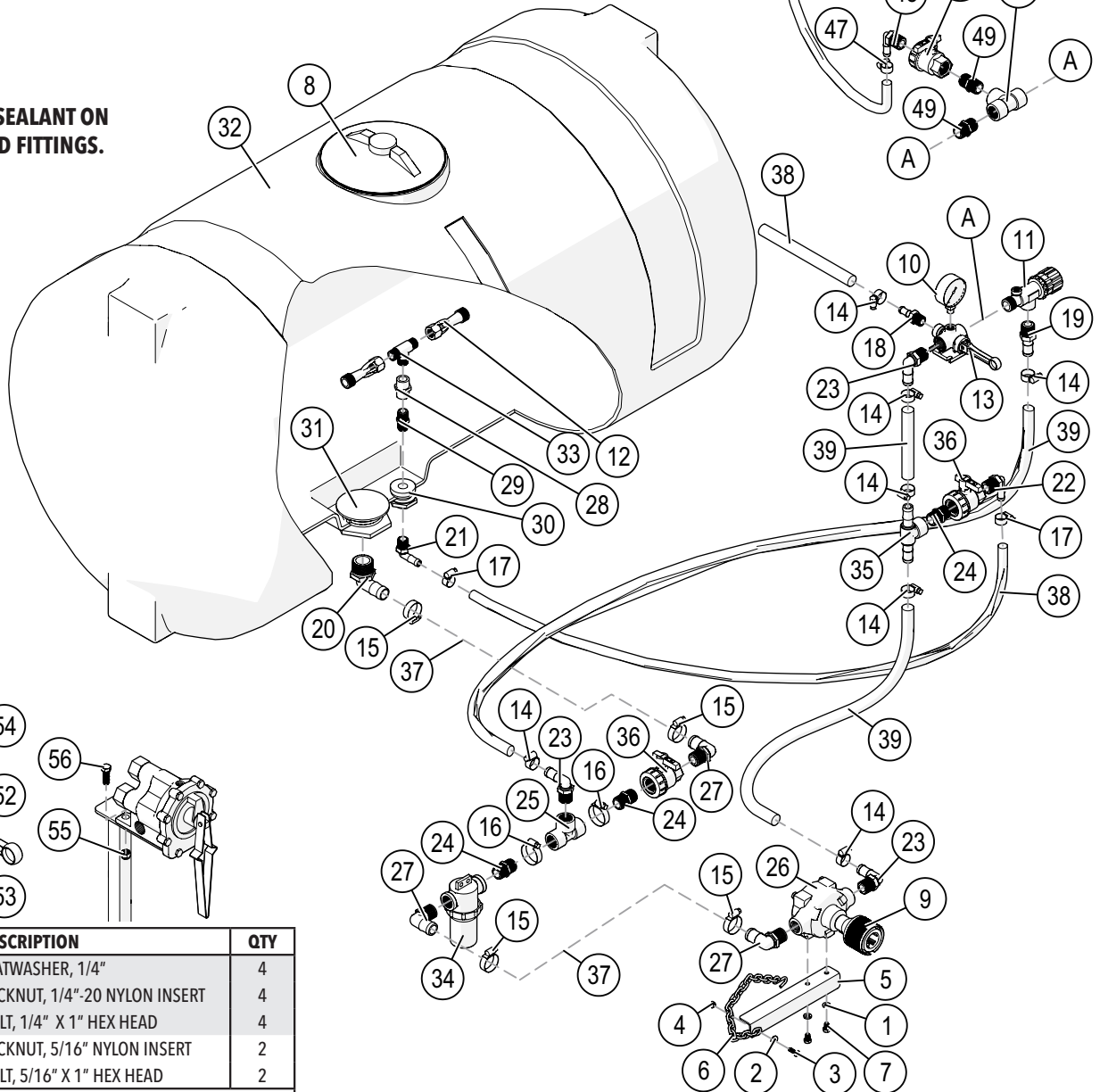

ID	ITEM NO	DESCRIPTION	QTY
52	00214	FLATWASHER, 1/4"	4
53	02772	LOCKNUT, 1/4"-20 NYLON INSERT	4
54	04055	BOLT, 1/4" X 1" HEX HEAD	4
55	02802	LOCKNUT, 5/16" NYLON INSERT	2
56	02990	BOLT, 5/16" X 1" HEX HEAD	2

Please order replacement parts by PART NO. and DESCRIPTION

## PARTS LIST BREAKDOWN

ID	ITEM NO	DESCRIPTION	QTY
1	00036	WASHER, LOCK 0.3125	2
2	00214	WASHER, FLAT, .25	1
3	01076	BOLT .25NC X .75 GR5 HEX	1
4	02772	NUT, .25NC LOCK NYLON INSERT	1
5	04298	ROLLER PUMP MOUNTING	1
6	04299	ROLLER PUMP CHAIN HOOK ASSEMBLY	1
7	04305	BOLT, 5/16NC X .50 GR5 HEX	2
8	09319	8" FILLWELL COVER	1
9	1321 0012	QUICK COUPLER, MULTI-SPEED	1
10	160GB	GAUGE BRASS 160#	1
11	23340PP	VALVE, PRESSURE RELIEF, 3/4"	1
12	5044 1	AGITATOR JET .50 X .75	2
13	6B1	DIRECT-O-VALVE, 3/4" X 1/2" (SINGLE SECTION)	1
-	36301NY	REPLACEMENT NYLON HANDLE	-
14	B12H	CLAMP, GEAR, SS, .75" HOSE	7
15	B20H	CLAMP, GEAR, SS, F/1.0" HOSE	4
16	B24H	CLAMP, GEAR, SS, F/1.25" HOSE	2
17	B8H	CLAMP, GEAR, SS, .50" HOSE	4
18	BA1212	FTG, STR, .50" MPT X .50" HB, GFP	1
19	BA3434	FTG, STR, .75" MPT X .75" HB, GFP	1
20	BEL114 1	FTG, ELB, 1.25" MPT X 1" HB, GFP	1
21	BEL1212	FTG, ELB, .5" MPT X .5" HB, GFP	1
22	BEL3412	FTG, ELB, .75" MPT X .50" HB, GFP	2
23	BEL3434	FTG, ELB, .75" MPT X .75" HB, GFP	3
24	BM3400	FTG, NIP, .75" MPT, GFP	5
25	BTT34	FTG, TEE, .75" FPT, GFP	2
26	C6500	PUMP, ROLLER, LESS COUPLER	1
-	3430 0167	PARTS KIT (SEAL, O-RING, ROLLER)	-
27	EL3410	FTG, ELB, .75" MPT X 1" HB	2
28	FC1200	COUPLING 1/2" FPT POLY	1
29	M1200	FTG, NIPPLE, .50 NPT	1
30	P012DA	1/2" BULKHEAD FITTING (1.25 HOLE)	1
31	P114PAV	FTG, 1.25" THREAD (2.25" HOLE)	1
32	P150 32A	150 GALLON RMU TANK	1
	P200 32A	200 GALLON RMU TANK	
	P300 38A	300 GALLON RMU TANK	
33	R1212	FTG TEE .50 MPT (3x)	1
34	RVF34 80	STRAINER, 80 MESH X .75 FPT	1
-	RVF34C	REPLACEMENT CAP	-
-	RVF34GV	REPLACEMENT GASKET	-
-	RVF380	REPLACEMENT 80 MESH SCREEN	-
-	RVF34B	REPLACEMENT BOWL	-
35	T34F	FTG, TEE, .75 FPT X .75 HB	1
36	UV075FP	BALL VALVE, .75" SINGLE UNION	3
37	1010RB	RUBBER HOSE 1" ID PER FOOT	-
38	120RB	RUBBER HOSE 1/2" ID PER FOOT	-
39	340RB	RUBBER HOSE 3/4" ID PER FOOT	-
<b>THREE SECTION PLUMBING FOR REAR MOUNT W/ ROLLER PUMP</b>			
40	AA171	VALVE, TEE, <b>THREE SECTION</b>	1
-	AB17	PARTS KIT	-
41	BA3412	FTG, STR, .75" MPT X .5" HB, GFP	3
42	F3400	3/4" FPT PLUG	1
<b>Please order replacement parts by PART NO. and DESCRIPTION</b>			

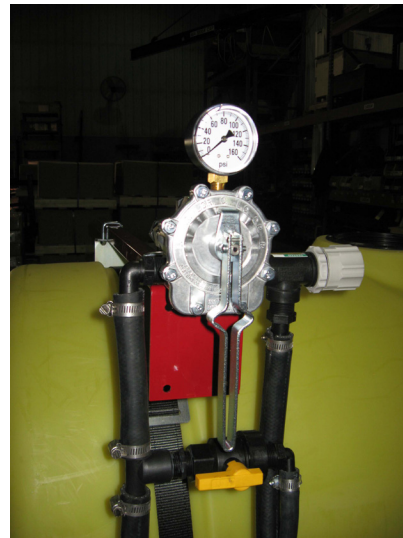

JET AGITATION ASSEMBLY - D3371PSA			
ID	ITEM NO	DESCRIPTION	QTY
15	5044 1	AGITATOR JET	2
28	FC1200	COUPLING 1/2" FPT POLY	1
29	M1200	FTG, NIPPLE 1/2" MPT	1
30	P012DA	FTG, 1/2" TANK	1
33	R1212	FTG, 1/2" MPT TEE	1
<b>Please order replacement parts by PART NO. and DESCRIPTION</b>			

OPTIONAL HAND GUN - DBHGR			
ID	ITEM NO	DESCRIPTION	QTY
43	05595-70	HAND GUN STORAGE BRACKET	1
44	12434	HAND SPRAY GUN	1
45	A3812	3/8" MPT X 1/2" HOSE BARB	1
46	B8H	HOSE CLAMP 1/2"	2
47	BEL3412	FTG, 3/4" MPT X 1/2" HOSE BARB ELBOW	1
48	BM3400	FTG, 3/4" MPT NIPPLE	2
49	BTT34	FTG, 3/4" FPT TEE	1
50	UV075FP	BALL VALVE 3/4" POLY	1
51	120RB	RUBBER HOSE 1/2" ID PER FOOT	-
<b>Please order replacement parts by PART NO. and DESCRIPTION</b>			

## START UP INSTRUCTIONS

1. Open valves #11, #13, and (2) #36.
2. Fill tank with water.
3. Start tractor PTO to engage spray pump. When the pressure begins to build on the gauge, close valve #13.
4. Adjust valve #11 to approximately 10 PSI over your desired spraying pressure. Open boom valve #13 or #40 and make final pressure adjustment with valve #11.
5. If desired boom pressure cannot be reached, close agitation valve #36 until pressure is achieved.

# PARTS BREAKDOWN

## OPTIONAL SINGLE SECTION ELECTRIC SOLENOID

ID	ITEM NO	DESCRIPTION	QTY
1	00214	WASHER, FLAT, .25	2
2	02802	NUT, .313 NC NYLON LOCK	2
3	02990	BOLT .313NC X 1.00 GR5 HEX	2
4	11635	ELECTRIC SOLENOID VALVE	1
-	11640	WIRING HARNESS F/ SOLENOID (NOT SHOWN)	1
5	02214	SCREW MACHINE #10 X .50 PHILLIPS FH	2
6	160GB	GAUGE BRASS 160#	1
7	17097	VALVE MOUNTING PLATE	1
8	23340PP	VALVE, PRESSURE RELIEF, 3/4"	1
9	BA1234	FTG, STR, .5" MPT X .75" HB, GFP	1
10	BA3434	FTG, STR, .75" MPT X .75" HB, GFP	1
11	BEL3412	FTG, ELB, .75" MPT X .50" HB, GFP	1
12	BEL3434	FTG, ELB, .75" MPT X .75" HB, GFP	1
13	BM3400	FTG, NIP, .75" MPT, GFP	1
14	BTT34G	FTG TEE .75" FPT W/ GAUGE PORT	1
15	UV075FP	BALL VALVE, .75" SINGLE UNION	1

Please order replacement parts by PART NO. and DESCRIPTION

**NOTE: USE THREAD SEALANT ON ALL THREADED FITTINGS.**

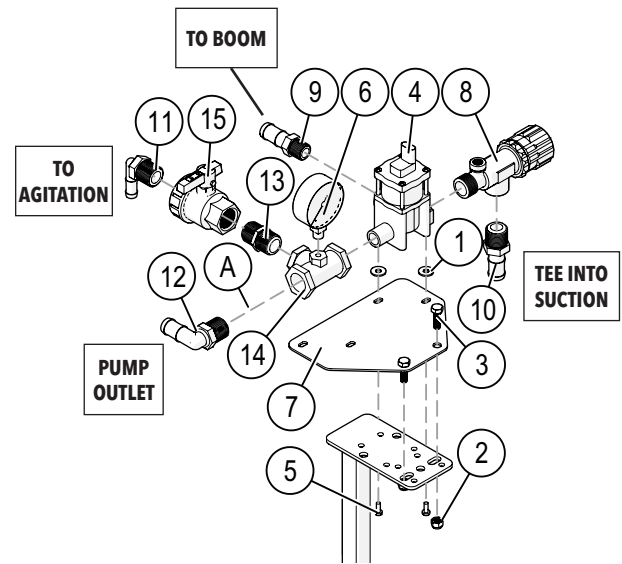

## A - PLUMB IN FITTINGS POINT - OPTIONAL HAND GUN - DBHGR OPTIONAL HOSE REEL - 9416025

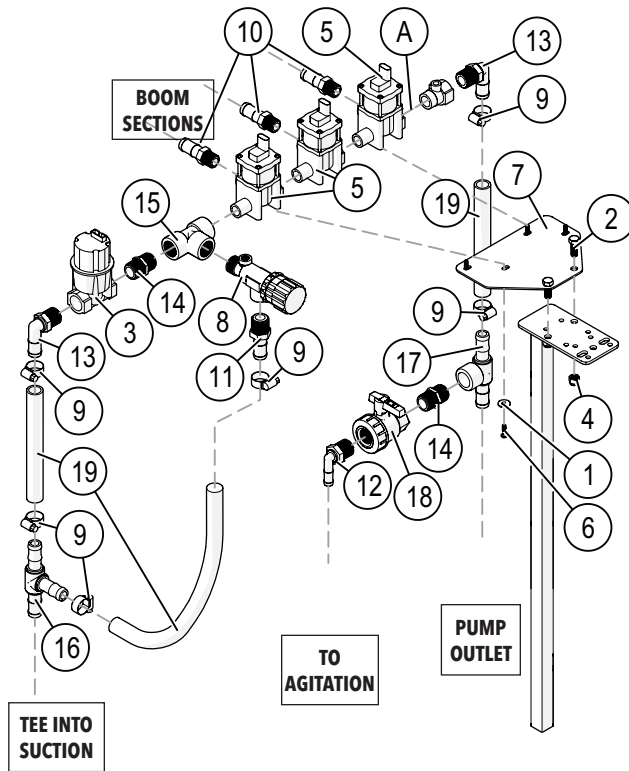

## OPTIONAL THREE SECTION ELECTRIC SOLENOID

ID	ITEM NO	DESCRIPTION	QTY
1	00214	WASHER, FLAT, .25	4
2	00907	BOLT .375NC X 1.00 GR5 HEX	2
3	01057	REGULATOR VALVE	1
4	02592	NUT, .375NC NYLON LOCK	2
5	11635	ELECTRIC SOLENOID VALVE	3
-	5747	3 SECTION CONSOLE W/ HARNESS, GAUGES & SCREWS (NOT SHOWN)	-
6	02214	SCREW MACHINE #10 X .50 PHILLIPS FH	4
7	17097	VALVE MOUNTING PLATE	1
8	23340PP	VALVE, PRESSURE RELIEF, 3/4"	1
9	B12H	CLAMP, GEAR, SS, .75" HOSE	6
10	BA1234	FTG, STR, .5" MPT X .75" HB, GFP	3
11	BA3434	FTG, STR, .75" MPT X .75" HB, GFP	1
12	BEL3412	FTG, ELB, .75" MPT X .50" HB, GFP	1
13	BEL3434	FTG, ELB, .75" MPT X .75" HB, GFP	2
14	BM3400	FTG, NIP, .75" MPT, GFP	2
15	BTT34	FTG, TEE, .75" FPT, GFP	1
16	T34	FTG, TEE, .75 FPT X .75 HB	1
17	T34F	FTG, TEE, .75 FPT X .75 HB	1
18	UV075FP	BALL VALVE, .75" SINGLE UNION	1
19	340RB	HOSE EPDM .75	3

PLEASE ORDER REPLACEMENT PARTS BY PART NO. AND DESCRIPTION

**NOTE: USE THREAD SEALANT ON ALL THREADED FITTINGS.**

## START UP INSTRUCTIONS FOR 3 SECTION ELECTRIC CONTROL USING A ROLLER PUMP

1. Open the valve in pump suction line, valve to agitation and manual pressure adjust valve.
2. Fill the tank with water.
3. Engage the sprayer pump to 540 RPM and start closing the manual pressure relief valve till pressure starts to rise (approximately halfway or 50 PSI).
4. Close the agitation valve till the pressure rises 5 more PSI.
5. On the control console, turn on the master switch and the 3 boom switches. Using the pressure switch, adjust till desired spraying pressure is achieved.
6. If desire pressure cannot be achieved, you may need to close the manual pressure relief valve and/or agitation valve. Tractor RPM may also need to be increased. If pressure is still not achieved, you may be exceeding the pumps capacity and need to use a lower application rate and smaller tips.
7. Always check wit your chemical dealer or chemical label for proper application rates and pressures.

HYDRAULIC PUMP PLUMBING PARTS BREAKDOWN FOR 300 GALLON REAR MOUNT

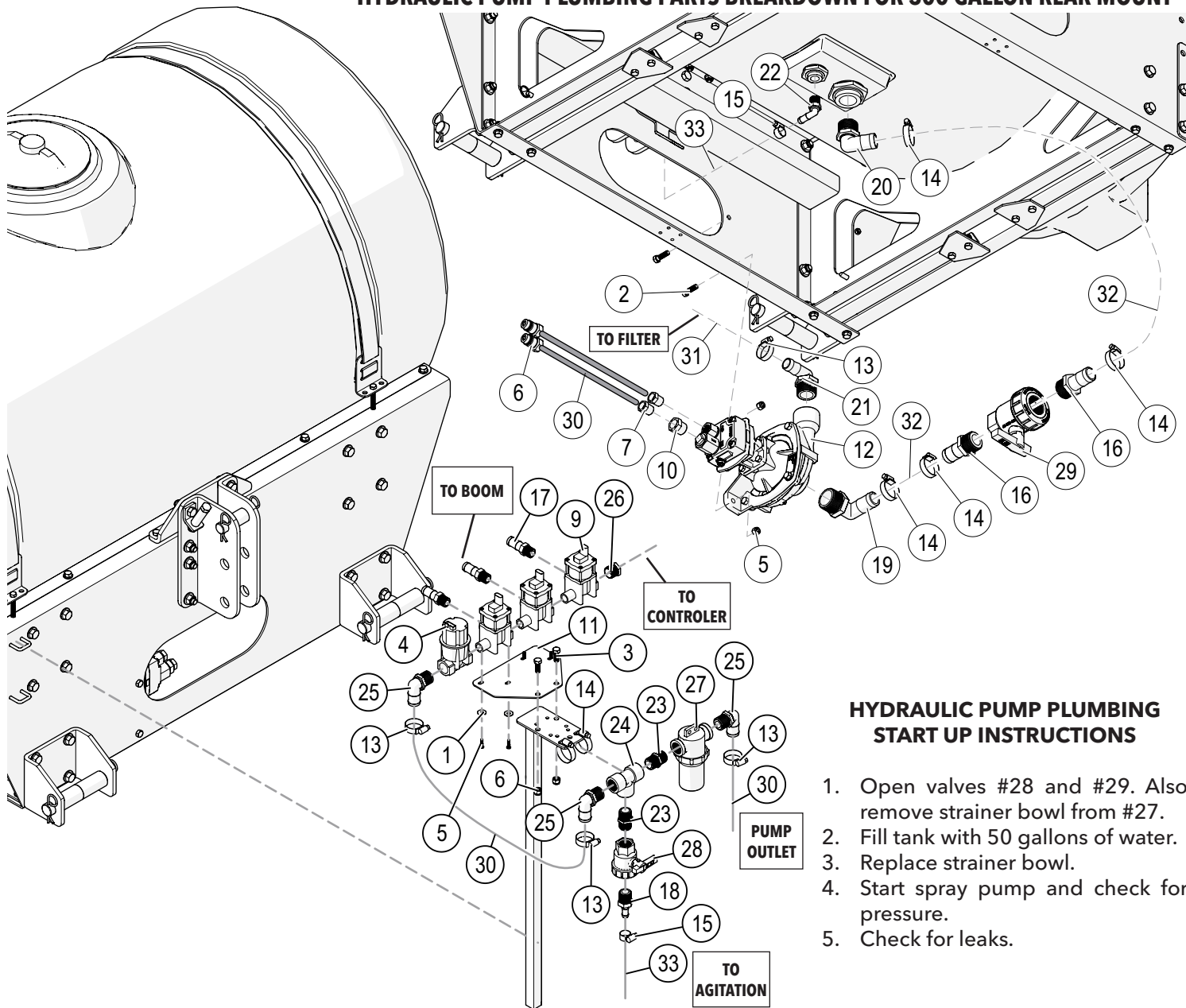

HYDRAULIC PUMP PLUMBING START UP INSTRUCTIONS

1. Open valves #28 and #29. Also remove strainer bowl from #27.
2. Fill tank with 50 gallons of water.
3. Replace strainer bowl.
4. Start spray pump and check for pressure.
5. Check for leaks.

ID	ITEM NO	DESCRIPTION	QTY
1	00214	WASHER, FLAT, .25	4
2	00523	BOLT .375NC X 1.25 GR5 HEX	2
3	00907	BOLT .375NC X 1.00 GR5 HEX	2
4	01057	REGULATOR VALVE	1
5	02214	SCREW MACHINE #10 X .50 PHILLIPS FH	4
6	02592	NUT, .375NC NYLON LOCK	4
7	05197	QUICK COUPLER .50 FPT WITH MALE TIP	2
8	05831	FTG HYD STR. .50 MPTX .375 FPT REDUCER BSHG	2
9	11635	ELECTRIC SOLENOID VALVE	3
10	13718	FTG HYD STR. .75 MPTX .50 FPT REDUCER BSHG	1
11	17097	VALVE MOUNTING PLATE	1
12	9303C-HM1C	HYPRO PUMP	1
13	B20H	CLAMP, GEAR, SS, F/1.0" HOSE	4
14	B24H	CLAMP, GEAR, SS, F/1.25" HOSE	6
15	B8H	CLAMP, GEAR, SS, .50" HOSE	2
16	BA114	FTG, STR, 1.25" MPTX 1.25" HB, GFP	2
17	BA1234	FTG, STR, .5" MPTX .75" HB, GFP	3
18	BA3412	FTG, STR, .75" MPTX .5" HB, GFP	1

PLEASE ORDER REPLACEMENT PARTS BY PART NO. AND DESCRIPTION

ID	ITEM NO	DESCRIPTION	QTY
19	BEL112 114	FTG, ELB, 1.50" MPTX 1.25 HB, GFP	1
20	BEL114	FTG, ELB, 1.25" MPTX 1.25" HB, GFP	1
21	BEL114 1	FTG, ELB, 1.25" MPTX 1" HB, GFP	1
22	BEL1212	FTG, ELB, .5" MPTX .5" HB, GFP	1
23	BM3400	FTG, NIP, .75" MPT, GFP	2
24	BTT34	FTG, TEE, .75" FPT, GFP	1
25	EL3410	FTG, ELB, .75" MPTX 1" HB	3
26	RB3418	3/4" MPT X 1/8" MPT REDUCER BUSHING	
27	RVF34 80	STRAINER, 80 MESH X .75 FPT	1
28	UV075FP	BALL VALVE, .75" SINGLE UNION	1
29	UV125FP	1.25" BALL VALVE	1
30	11277	HOSE HYD. .50 X 96"	2
31	1010RB	HOSE EPDM 1" X 4 SPIRAL	-
32	1140RB	HOSE EPDM 1.25" X 4 SPIRAL	-
33	120RB	HOSE EPDM .50" X 2 SPIRAL	-

PLEASE ORDER REPLACEMENT PARTS BY PART NO. AND DESCRIPTION

# BOOM MOUNTING BRACKETS INSTALLATION

## BREAKDOWN AND INSTRUCTIONS

See your Boom Owners Manual for complete installation and replacement parts of the Truss-T Boom

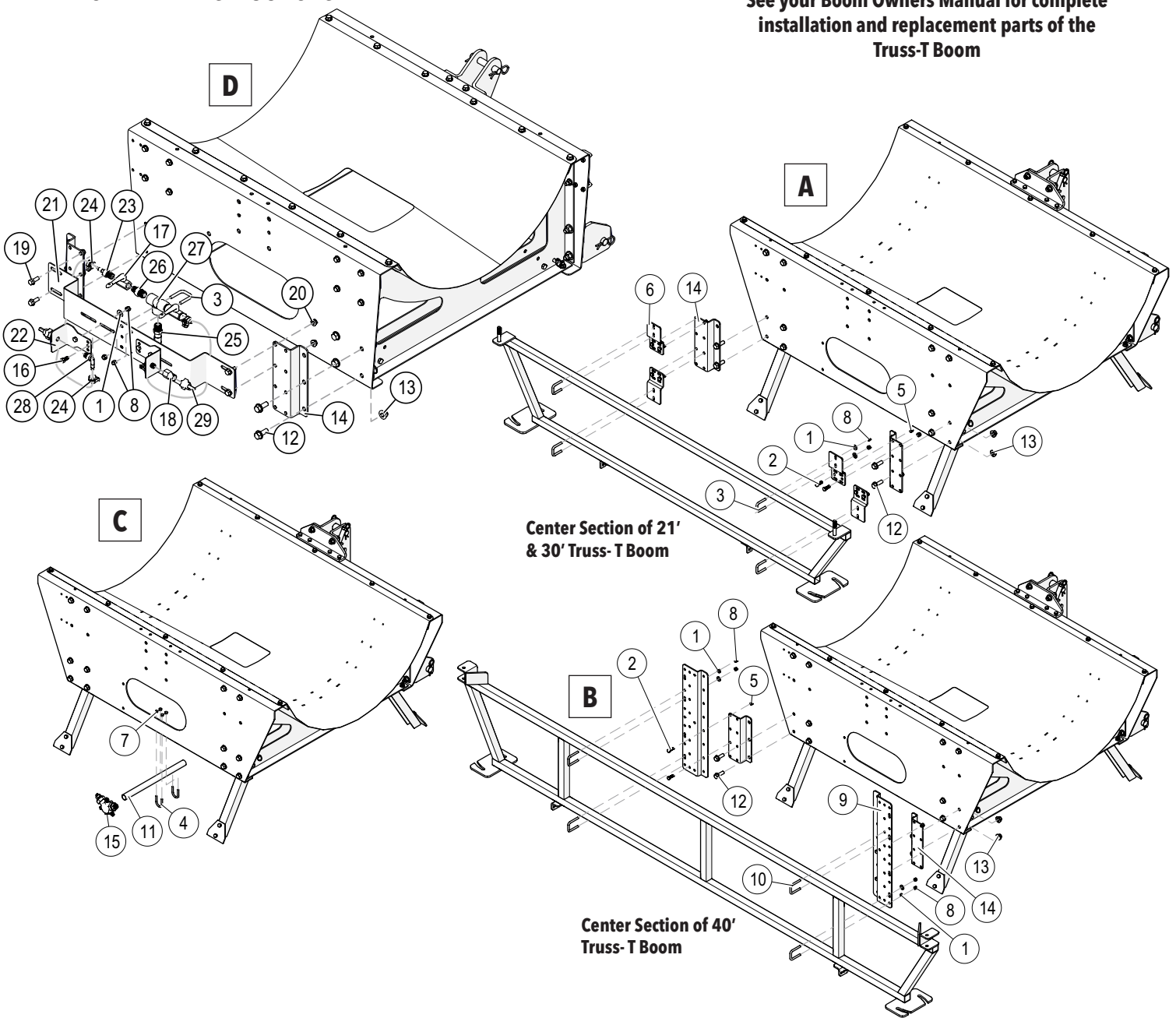

Center Section of 21' & 30' Truss-T Boom

Center Section of 40' Truss-T Boom

ID	ITEM NO	DESCRIPTION	QTY
1	00004	WASHER, FLAT, .313	16
2	00907	BOLT .375NC X 1.00 GR5 HEX	8
3	00909	U-BOLT, SQ, .313NC X 1	4
4	00955	U-BOLT, RND, .250NC X 1.00 X 2.00	2
5	02592	NUT, .375NC NYLON LOCK	9
6	02678	UNIVERSAL BOOM MOUNTING	4
7	02772	NUT, .25NC LOCK NYLON INSERT	4
8	02802	NUT, .313 NC NYLON LOCK	16
9	03275	BOOM MOUNT	2
10	05678	U-BOLT, SQ, .313NC X 1.531 X 2.25	4
11	07459	REAR MOUNT BOOMJET TUBE	1
12	16589	BOLT .50NC X 1.50 GR5 HEX FLANGE	4
13	16590	NUT, .50NC LOCK, NY. INSERT FLANGE	4
14	17089	BOOM MOUNT	2
15	SEE CATALOG	5880 BOOMJET NOZZLE	1

PLEASE ORDER REPLACEMENT PARTS BY PART NO. AND DESCRIPTION

ID	ITEM NO	DESCRIPTION	QTY
16	01263	BOLT .313NC X .75 GR5 HEX	4
17	03900	VALVE, BRASS, .375" FPT (2X), 2 WAY	2
18	12472	FTG .25" FPT TURN CAP ADAPTER	2
19	16259	BOLT .375NC X 1.00 GR5 HEX FLG	4
20	16260	NUT, .375NC NY LOCK FLANGE	4
21	18322	BOOMLESS MOUNT FOR RM	1
22	18323	BOOMLESS TIP HOLDER	2
23	A3838	FTG, .375 MPT X .375 HB	2
24	B6PH	CLAMP, NYLON FOR .375 HOSE	4
25	BA1234	FTG, STR, .5" MPT X .75" HB, GFP	1
26	BM1238	FTG, STR, .50" MPT X .375" HB	2
27	BTT12	FTG, TEE, .50" FPT, GFP	1
28	EL1438	FTG, ELB, .25" MPT X .375" HB	2
29	FC-XT010	TIP BOOM EXTENDER	2

PLEASE ORDER REPLACEMENT PARTS BY PART NO. AND DESCRIPTION

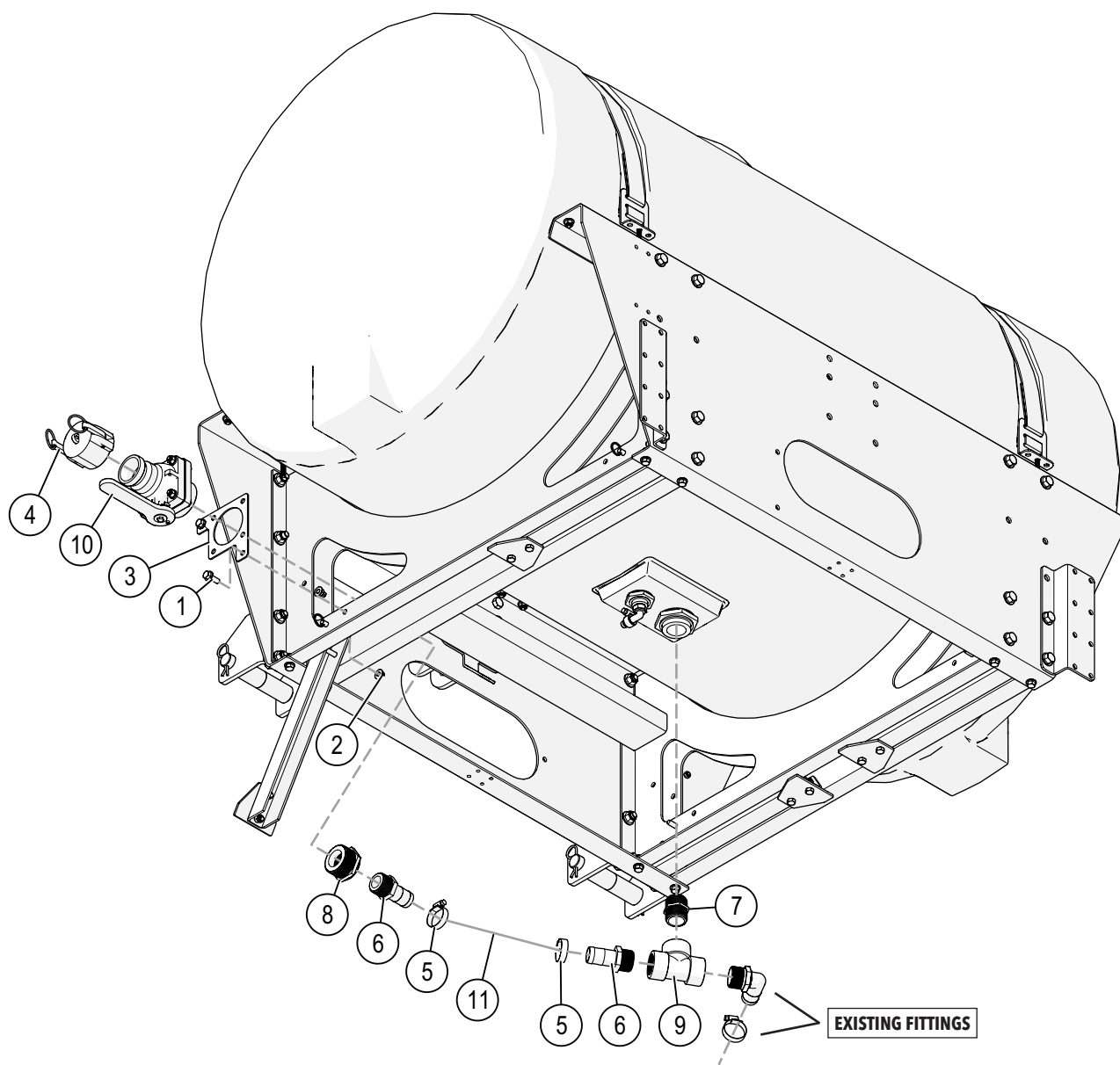

**BOOM INSTALLATION INSTRUCTIONS**

**A. 21' & 30' Boom:** Attach boom mount angles (#6) to Boom Mount Brackets (#14) using hardware. Attach boom center section to boom mount angles with U-bolts and hardware provided with boom.

**B. 40' Boom:** Attach boom mount angles (#9) to Boom Mount Brackets (#14) using hardware. Attach boom center section to boom mount angles with U-bolts and hardware provided with boom.

**C. Boomless Nozzle:** Attach BoomJet Tube (#11) to rear of frame using two 1/4" round U-bolts (#4) and hardware provided with boom.

**D. Boomless Nozzle:** Attach Boomless Boom (#21) to Boom Mount Brackets (#14) using hardware. Install Boomless Tip Holders (#22) to Boomless Boom (#21) with hardware shown. Adjust spacing of Boomless Tip Holders to desired spray pattern and overlap.

**A. and B. Boom:** Relocate SMV sign and bracket to boom's center section with U-bolt provided (P.11 #21). Position SMV in which is it visible with boom folded and centered as much as possible.

**OPTIONAL QUICK REFILL #6383**

ID	ITEM NO	DESCRIPTION	QTY
1	16259	BOLT .375NC X 1.00 GR5 HEX FLG	2
2	16260	NUT, .375NC NYLON LOCK FLG	2
3	17276	QUICK REFILL BRACKET	1
4	634B2020	QUICK COUPLER, 2" CAP	1
5	B24H	CLAMP, GEAR, SS, F/1.25" HOSE	2
6	BA114	FTG, STR, 1.25" MPT X 1.25" HB, GFP	2
7	BM1140	FTG, NIP, 1.25" MPT, GFP	1
8	BRB200 114	FTG, REDUCER BSHG, 2" MPT X 1.25" FPT, GFP	1
9	BTT114	FTG, TEE, 1.25" FPT, GFP	1
10	VSF204FP	QUICK REFILL VALVE 2" FP X FML NPT THREADS	1
11	1140RB	HOSE EPDM 1.25" X 4 SPIRAL	-

Please order replacement parts by PART NO. and DESCRIPTION

# HOSE REEL INSTALLATION

## PARTS BREAKDOWN

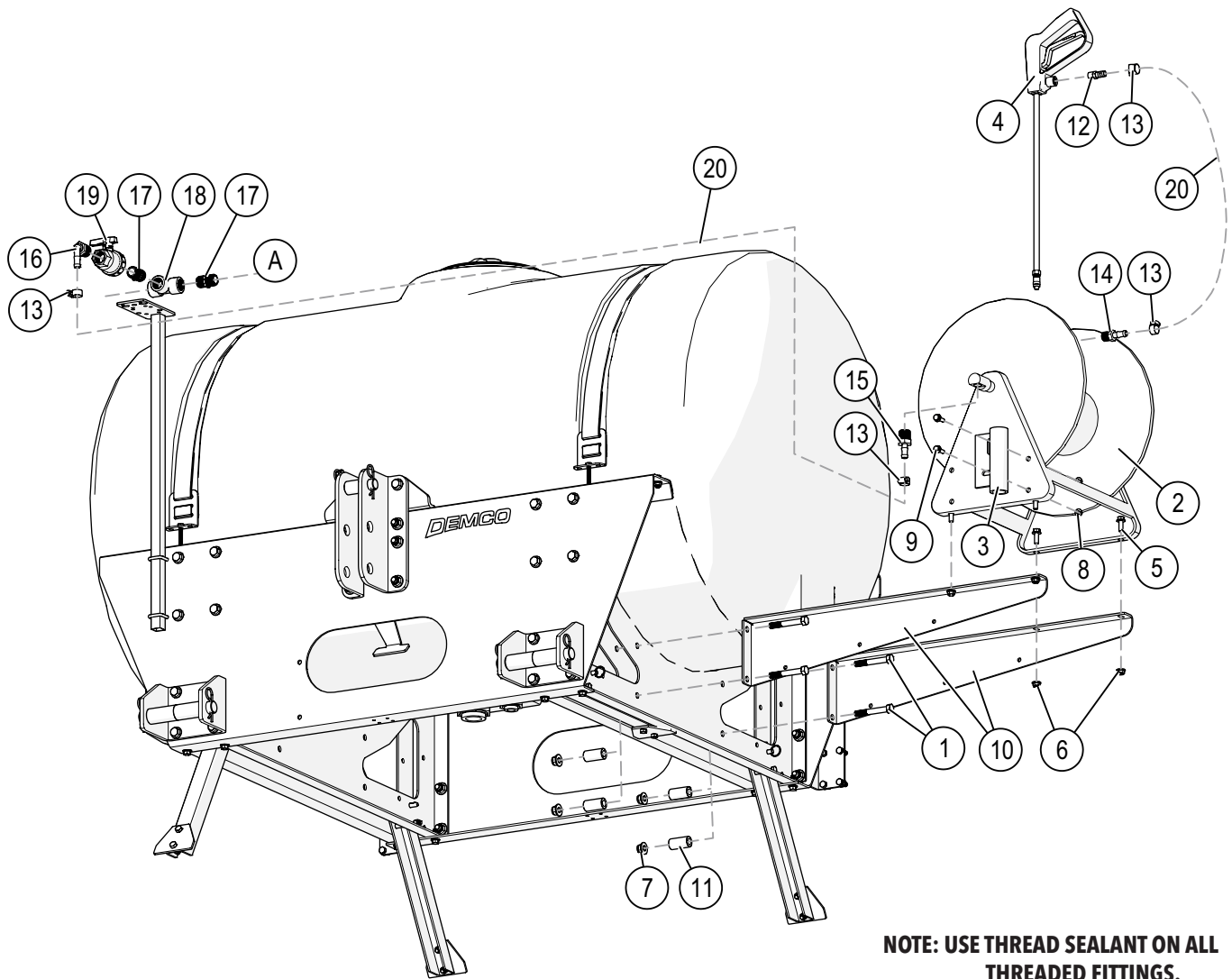

**NOTE: USE THREAD SEALANT ON ALL THREADED FITTINGS.**

OPTIONAL HOSE REEL WITH HAND GUN - 9416025			
ID	ITEM NO	DESCRIPTION	QTY
1	01897	BOLT .50NC X 3.50 GR5 HEX	4
2	03279	HOSE REEL	1
3	03332	ASSY, HOSE GUN HOLDER	1
4	12434	SPRAY GUN, 18" SYNTHETIC HAND	1
5	16259	BOLT .375NC X 1.00 GR5 HEX FLG	4
6	16260	NUT, .375NC NY LOCK FLANGE	4
7	16590	NUT, .50NC LOCK, NY. INSERT FLANGE	4
8	17855	NUT, .313NC NY LOCK FLANGE	2
9	17856	BOLT .313NC X 1.00 GR5 HEX FLG	2
10	18376	HOSE REEL MOUNT	2
11	18377	SPACER F/ RM HOSE REEL	4
12	A3812	FTG, STR, .375 MPT X .50 HB	1
13	B8H	CLAMP, GEAR, SS, .50" HOSE	4
14	BA1212	FTG, STR, .50" MPT X .50" HB, GFP	1
15	BA3412	FTG, STR, .75" MPT X .5" HB, GFP	1
16	BEL3412	FTG, ELB, .75" MPT X .50" HB, GFP	1
17	BM3400	FTG, NIP, .75" MPT, GFP	2
18	BTT34	FTG, TEE, .75" FPT, GFP	1
19	UV075FP	BALL VALVE, .75" SINGLE UNION	1
20	120RB	HOSE EPDM .50" X 2 SPIRAL	-

Please order replacement parts by PART NO. and DESCRIPTION



# BOLT TORQUE



## TORQUE SPECIFICATION

Torque figures indicated are valid for non-greased or non-oiled threads and heads unless otherwise specified. Therefore, do not grease or oil bolts or capscrews unless otherwise specified in this manual. When using locking elements, increase torque values by 5%.

\* GRADE or CLASS value for bolts and capscrews are identified by their head markings.

## BOLT TORQUE DATA FOR STANDARD NUTS, BOLTS, AND CAPSCREWS.

Tighten all bolts to torques specified in chart unless otherwise noted. Check tightness of bolts periodically, using bolt chart as guide. Replace hardware with same grade bolt.

NOTE: Unless otherwise specified, high-strength Grade 5 hex bolts are used throughout assembly of equipment.

Bolt Torque for Standard bolts *						
"A"	GRADE 2		GRADE 5		GRADE 8	
	lb-ft	(N.m)	lb-ft	(N.m)	lb-ft	(N.m)
1/4"	6	(8)	9	(12)	12	(16)
5/16"	10	(13)	18	(25)	25	(35)
3/8"	20	(27)	30	(40)	45	(60)
7/16"	30	(40)	50	(70)	80	(110)
1/2"	45	(60)	75	(100)	115	(155)
9/16"	70	(95)	115	(155)	165	(220)
5/8"	95	(130)	150	(200)	225	(300)
3/4"	165	(225)	290	(390)	400	(540)
7/8"	170	(230)	420	(570)	650	(880)
1"	225	(300)	630	(850)	970	(1310)

Bolt Torque for Metric bolts *						
"A"	CLASS 8.8		CLASS 9.8		CLASS 10.9	
	lb-ft	(N.m)	lb-ft	(N.m)	lb-ft	(N.m)
6	9	(13)	10	(14)	13	(17)
7	15	(21)	18	(24)	21	(29)
8	23	(31)	25	(34)	31	(42)
10	45	(61)	50	(68)	61	(83)
12	78	(106)	88	(118)	106	(144)
14	125	(169)	140	(189)	170	(230)
16	194	(263)	216	(293)	263	(357)
18	268	(363)	--	--	364	(493)
20	378	(513)	--	--	515	(689)
22	516	(699)	--	--	702	(952)
24	654	(886)	--	--	890	(1206)

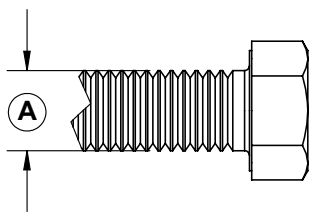

GRADE-2

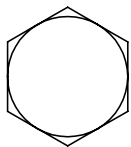

GRADE-5

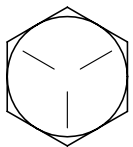

GRADE-8

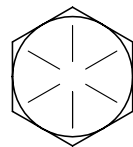

CLASS 8.8

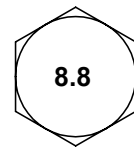

CLASS 9.8

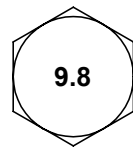

CLASS 10.9

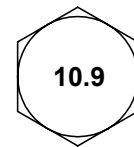

Downtime caused by breakdowns is costly and time consuming. Many breakdowns can be eliminated by periodic equipment maintenance. By spending a little time running over this checklist before seasonal spraying application time and following proper after-season care, you can save time and money later on.

## **WARNING: To Prevent Serious Injury Or Death**

- Keep hands, feet, and loose clothing away from rotating parts.
- Wear the protective clothing recommended by your chemical and fertilizer manufacturer when working with chemicals.

### **Check Before Going To The Field :**

#### **1. NOZZLES**

Check the tip for excessive wear by checking for grooves in or near the tip opening. Check the nozzle spacing by starting at center and working outwards. Check boom for proper height.

#### **2. HOSES**

Check all hoses for worn or soft spots. Be sure all hose clamps are tightened and hoses are not kinked or pinched. Check for leakage in any of the lines.

#### **3. TANK**

Remove and clean the agitator orifices. Check the orifices for excessive wear by checking for grooves in or near the orifice opening. Inspect the fitting and grommets to ensure they are in good condition.

#### **4. CONTROLS**

Check for leakage, plugging, or wear on all valves, fittings, etc. Clean off any buildup of foreign material.

#### **5. PUMP**

Check to be sure the pump turns freely.

#### **6. FRAME**

Be sure all bolts are tightened.

#### **7. REPLACEMENT PARTS**

Replace all worn or damaged parts.

### **After Season Care:**

**NOTE: It is important that when cleaning the sprayer one wears proper safety equipment. See your chemical or fertilizer package for this information.**

1. After spraying chemicals, run water mixed with cleaners through the tank, pump and all hose hookups. If wettable powder dries out in the system, it is very difficult to put back into suspension and can cause malfunction, damage or injury.
2. The tank, when cleaned, should have all openings closed or covered to keep dirt from blowing in.
3. The pump should be flushed with soluble oil and the pump ports plugged to keep out moisture and air.
4. Disassemble the tips and rinse with water or cleaning solution. (Appropriate for chemical sprayed.)
5. Clean the tip opening with a wooden toothpick. Never use wire or a hard object that could distort the opening.
6. Be sure to dispose of all unused chemicals or solutions in a proper and ecologically sound manner.
7. Water rinse and dry the tips before storing.

**NOTE: Do not let any agricultural chemical stand in the applicator tanks when not in use. Chemicals left standing in equipment that is not in use shorten the life of tanks, pumps, hoses, etc. The longer chemicals stand, the more the water evaporates and the stronger the chemical solution becomes.**

**NOTE: DEMCO does not and will not make any recommendations concerning the application of various chemicals or solutions. These recommendations relate to either amount or procedure of materials applied. If you have any questions regarding the application of certain chemicals or solutions, contact your chemical supplier and follow chemical manufacturer recommendations as well as all licensing and use restrictions or regulations.**

**DEMCO**

4010 320th St., Boyden, IA. 51234

Phone: (712) 725-2311

Fax: (712) 725-2380

Toll Free: 1-800-54DEMCO (1-800-543-3626)

**Demco warranty policies, operator manuals, and product registration  
can be found online:**

**[www.demco-products.com](http://www.demco-products.com)**