



*Doing Our Best to Provide You the Best*

8D000003, Rev AL  
05/26

---

## **DROP DECK TRAILERS (ALL MODELS)**

---

<b>TANDEM AXLE</b>	<b>40', 45', 48', 53'</b>
<b>SPREAD TANDEM</b>	<b>43', 45', 48', 53'</b>
<b>TRI-AXLE</b>	<b>48', 53'</b>



# **OPERATOR MANUAL**

## TABLE OF CONTENTS

---

<b>Basic Features &amp; Operations Section .....</b>	<b>3</b>
Product Disclaimer.....	3
Introduction.....	4
To The Dealer .....	6
To The Owner .....	7
Trailer Information .....	8
Trailer Specifications and Features .....	9
Safety.....	10
Safety Decals.....	13
Bolt Torque Specifications & Requirements .....	14
Lights & Wiring .....	16
Trailer Towing.....	17
Operating Safety.....	19
Service / Maintenance / Cleaning.....	20
Flooring Care .....	21
Coupling and Uncoupling the Trailer .....	22
iABS Brake System .....	26
Braking with ABS .....	28
Landing Gear .....	29
Spring Suspension Information .....	31
Air Ride Suspension Information .....	35
Disc Brake Axles .....	38
Drum Brake Axles .....	42
Lubrication Guide .....	45
<b>Optional Parts Section .....</b>	<b>48</b>
Aluminum Toolbox .....	49
Demco Mudflaps / Rear Strobe Lights .....	51
Front Headache Rack Assembly.....	52
Ramps - Tail & Middle Assembly .....	53
Ramps - Top Deck Assembly .....	54
Ramps - Top Deck Bulkhead .....	55
Ramps - Top Deck Installation .....	56
Ramps - Top Deck Ramp Storage .....	57
Ramps - Top Deck Storage Installation .....	58
Winch Options.....	59

In this document you will find information based on available knowledge at the time of its publication. To be accurate with the information, every effort was made but may not cover all details or variations of a trailer or provide every possibility in connection with its production, operation and maintenance. A Feature and Option may be presented in the manual that is not relevant to this trailer. Demco assumes no obligation of notice, to holders of this document, with changes made to a product.

**SPECIFICATIONS AND DESIGN ARE SUBJECT TO CHANGE WITHOUT NOTICE.**

Demco is often making improvements and developing new designs. In doing so, we reserve the right to make changes and/or improvements without obligation for equipment sold beforehand. Self-modification to our trailers may affect the operation, function, and safety, so this is not advised. If a replacement part is necessary, Demco should supply it, please contact your nearest dealer or Demco.

**DEMCO STATEMENT OF PRODUCT SAFETY**

As a producer of agricultural and transportation equipment, Demco is fully aware of its responsibility of providing its customers products that perform their expected use, in a truly safe manner. Safety considerations shall be a fundamental and high precedence part of all engineering/design analysis and judgments involving Demco products. It is our stated policy that our products will be manufactured to coincide with the safety standards specified by the National Association of Trailer Manufacturers and/or any other officially recognized standards at the time manufactured. However, this statement should not be translated to mean that our product will uphold against a customer's own carelessness or disregard for common safety practices specified in each product's manual, nor will we be accountable for any such occurrence.

### INTRODUCTION

At Demco we strive to design, produce and deliver the highest quality trailer on the market. Our employees have a strong background of knowledge and combined experience in manufacturing to put quality workmanship into our products. In this manual you will find information covering all models of the Demco Drop Deck Trailer line. Use the table of contents to locate specific areas of interest.

### GENERAL INFORMATION

Demco requires that you and anyone else who will be operating and maintaining the trailer read and understand the guidelines in the manual for safe, efficient, and trouble free operations. Proper maintenance, adjustments and use will result in many years of service. Keep this manual handy for frequent reference and to pass on to new operators or owners. If assistance, information, or additional copies of the manual are needed, contact the nearest dealer, a distributor, or Demco.

### PLEASE NOTE

- All documents within the manual referring to products not manufactured by Demco have been printed with the permission of the respective manufacturer.
- All references to driver, passenger, front and rear of the trailer are determined from a position behind the trailer and facing forward.

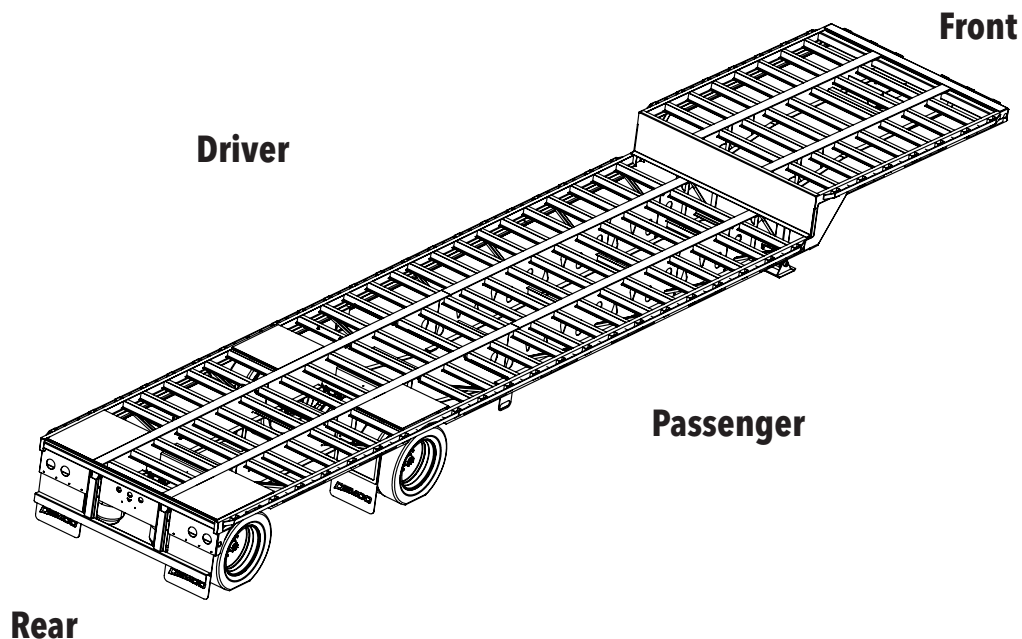

### WARRANTY POLICIES

Please go online to review Demco Warranty Policies. The warranty information is located at [www.demco-products.com/resources/warranty-policies](http://www.demco-products.com/resources/warranty-policies).

The Demco Warranty does not cover the following:

- 1) Cleaning, transporting, mailing and service call charges.
- 2) Depreciation or damage caused by normal wear, accidents, improper protection or improper use.

Record your trailer model and serial number in the space provided below. You will need this to register your product warranty. Your dealer will also need this information to provide prompt, efficient service when ordering replacement parts or additional options for your trailer.

<b>MODEL NO.</b> _____
<b>SERIAL NO.</b> _____
<b>DATE PURCHASED</b> _____

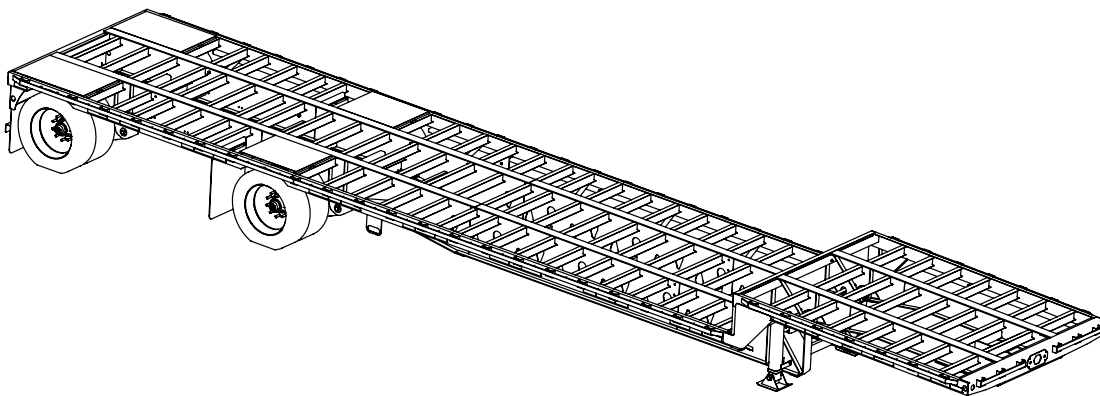

**Model and Serial Numbers are located on the front, passenger corner of the trailer. Please contact Demco at 1-800-543-3626 if you need assistance locating these numbers.**

**Pre-Delivery Checklist**

Inspect the trailer thoroughly after shipment to be certain it is functioning properly before delivering it to the customer. The following checklist is a reminder of points to cover. Check off each item as it is found satisfactory or after proper adjustment is made.

- 1. All hardware properly tightened
- 2. Proper 5th wheel fit
- 3. Lubrication of grease fittings
- 4. Lug nuts are tight
- 5. All decals properly located and readable
- 6. Lights function properly
- 7. Brakes functioning properly
- 8. Overall condition (touch up any scratches, clean and polish)
- 9. Operator's manual included

**Date Delivered:** \_\_\_\_\_

**Signature of Salesman or Technician:** \_\_\_\_\_

**Delivery Checklist**

Review the operator's manual with the customer. Explain the following:

- 1. Safe operation and service
- 2. Correct trailer operation
- 3. Daily and periodic lubrication and maintenance
- 4. Daily and periodic inspections
- 5. Trouble shooting
- 6. Storing trailer
- 7. Demco parts and service policies
- 8. Have the customer write the trailer model and serial number in space provided in manual introduction.
- 9. Give customer the operator's manual and encourage the customer to read the manual carefully.
- 10. Customer to complete warranty registration on Demco's website.

**Date Delivered:** \_\_\_\_\_

**Signature:** \_\_\_\_\_

**Register  
Warranty  
One of  
Two Ways**

Thank you for your recent purchase of a New Demco Drop Deck Trailer. We're "Doing Our Best To Provide You The Best". However, in the event that a problem does occur, it is imperative that your warranty registration is on file so we can accurately respond to your specific circumstances. You will need the Model Number, Serial Number and Date of Purchase. (Space is provided on page 5 to record this information.)

**We have two easy ways to register your warranty:**

- **Call our toll free number and ask for warranty registration.  
1-800-543-3626**
- **Register on-line at:  
[www.demco-products.com/resources/product-registration](http://www.demco-products.com/resources/product-registration)**



**Manuals and Assistance**

This manual has been prepared to assist you in the operation of your new trailer and contains information pertaining to safety and operations.

Demco personnel are available to assist you if questions arise concerning the maintenance or operations of your trailer. 1-800-54DEMCO (800-543-3626).

To order any parts or additional options for your trailer, please contact your dealer or view our online manuals at: [www.demco-products.com](http://www.demco-products.com)

- Current manuals are listed in | Semi Trailers | Steel Drop Deck Trailers | Manuals (Located at the bottom of the page)
- Older manuals are listed in | Resources | Archived Manuals

## TRAILER INFORMATION

---

**GAWR (Gross Axle Weight Rating):** The maximum gross weight that an axle can support. It is the lowest of axle, wheel, or tire rating. Usually the tire or wheel rating is lower than the axle rating and determines the GAWR. The GAWR is listed on the VIN plate.

**GVWR (Gross Vehicle Weight Rating):** The maximum allowable gross weight of the trailer and its contents. The gross weight of the trailer includes the weight of the trailer and all of the items with it. GVWR is sometimes referred to as GTWR (Gross Trailer Weight Rating) or MGTW (Maximum Gross Trailer Weight). GVWR, GTWR and MGTW are all the same rating.

The sum total of the GAWR for all trailer axles may be less than the GVWR for the trailer, because some of the trailer load is to be carried by the tow vehicle, rather than by the trailer axle(s). The total weight of the cargo and trailer must not exceed the GVWR, and the load on an axle must not exceed its GAWR. The GVWR is listed on the VIN Plate.

**VIN (Vehicle Identification Number):** Identifies the trailer in four sections. The first section of three characters identifies the manufacturer. The second section consists of five characters (VIN positions 4-8), these are the attributes of the vehicle. The third section is one character which is the check digit. The fourth section consists of eight characters (VIN positions 10-17). The first character represents the vehicle model year, the second character represents the plant of manufacture. The third through eighth characters are a sequential production number. The VIN Plate is located on the main frame at the front, passenger side of the trailer.

**PSI (Pounds Per Square Inch):** The tire pressure measurement. The PSI is listed on the VIN Plate.

**Empty Weight:** Some information that comes with the trailer is not a reliable source for 'empty' weight. The shipping documents list average or standard weights and your trailer may be equipped with options. To determine the 'empty' or weight of your trailer, have trailer weighed at a commercial scale.

**Kingpin:** The coupler on the front of the trailer that connects to the fifth wheel plate of the tow vehicle.

**Fifth Wheel Plate:** A device on the tow vehicle that pulls and supports the weight of the trailer.

**Trailer Lighting and Braking Connectors:** A device that connects electrical power from the tow vehicle to the trailer. If your trailer has electric brakes, the connector will also supply power to the brakes from the tow vehicle.

**Landing Gear:** A device on the trailer that is often referred to as the 'jack', used to raise and lower the trailer and for storage of the trailer. To operate the landing gear, pull the crank shaft outward for high gear and push in for low gear speed. This is also the same handle, which will be used to open the hopper doors. Demco uses the Holland - Model Atlas 55 as standard equipment on the 34' thru 42' trailers. The Holland - Model Atlas 55 with Dropleg is used on the 24', 28' and 30' trailers for improved swing auger clearance.

**Registration Holder:** This is located on the center of the kingpin. Use this to keep the registration with the trailer at all times. The registration holder is often referred to as the "manifest" holder.

1. 3 SAF Holland Axle Configurations  
(Tandem, Spread Tandem, or Triple)
2. ABS Standard on 1 Axle
3. Apitong Deck Flooring
4. Heavy Duty SAF Holland Atlas 55 Landing Gear
5. 24" King Pin Setting
6. Midship Turn Signals on Sides of Trailer
7. LED Lights on Rear of Trailer
8. Other Available Options:
  - Air Ride Suspension
  - ABS Installed on Second Axle
  - 18" King Pin Setting
  - Steel Flooring (Available on 43' w/Beaver Tail, 48' and 53')
  - Front Headache Rack
  - Removable Top Deck Ramps
  - Spring Assist Rear Ramps
  - Aluminum Rims
  - Demco Logo Mudflaps
  - Rear Strobe Light Kit
  - Sliding or Weld-On Winch Options
  - Aluminum Toolbox

\*Consult your dealer or online brochure for more details.

**Demco Steel Drop Deck Trailer Specifications**

<b>Trailer Description</b>	<b>Tandem-Axle</b>	<b>10:1 Spread</b>	<b>Tri-Axle</b>
40' Tandem Axle	X	N/A	N/A
45' Tandem Axle	X	X	N/A
48' Tandem Axle	X	X	N/A
53' Tandem Axle	X	X	N/A
40' Tandem Axle + 5' Beaver Tail & Twin Ramps	X	N/A	N/A
43' Tandem Axle + 5' Beaver Tail & Twin Ramps	X	X	N/A
45' Tandem Axle + 5' Beaver Tail & Twin Ramps	X	X	N/A
48' Tandem Axle + 5' Beaver Tail & Twin Ramps	X	X	N/A
48' Triple Axle	N/A	N/A	X
53' Triple Axle	N/A	N/A	X
48' Triple Axle + 5' Beaver Tail & Twin Ramps	N/A	N/A	X

**RECOGNIZE SAFETY INFORMATION**

This is the safety-alert symbol. When you see this symbol on your machine or in this manual, be alert to the potential for personal injury. Follow recommended precautions and safe operation practices.

**FOLLOW SAFETY INSTRUCTIONS**

- Carefully read all safety messages in the manual and on your machine safety signs.
- Keep safety signs in good condition.
- Replace missing or damaged safety signs.
- Learn how to operate the machine and how to use controls properly.
- Do not let anyone operate without instruction.
- Keep your machine in proper working condition.
- Unauthorized modification to the machine may impair the function and/or safety and affect machine lift.

**PROTECT CHILDREN AND BYSTANDERS**

- Before you back, LOOK CAREFULLY behind for children.
- Clear area of children, pets and bystanders.

**ADOPT SAFE DRIVING PRACTICES**

- Always drive at a safe speed relative to local conditions and ensure that your speed is low enough for an emergency stop to be safe and secure.
- Keep speed to a minimum.
- Reduce speed prior to turns to avoid the risk of overturning.
- Avoid sudden uphill turns on steep slopes.
- Always keep the tractor or towing vehicle in gear to provide engine braking when going downhill. Do not coast.
- Do not drink and drive.
- Comply with state and local laws governing highway safety and movement of equipment on public roads.
- Use approved accessory lighting and necessary warning devices to protect operators of other vehicles on the highway during daylight and nighttime transport.

**HIGHWAY AND TRANSPORT OPERATIONS**

- Plan your route to avoid heavy traffic.
- Be a safe and courteous driver. Always yield to oncoming traffic in all situations, including narrow bridges, intersection, etc.
- Be observant of bridge loading ratings. Do not cross bridges rated lower than the gross weight at which you are operating.
- Always operate the tractor trailer in a position to provide maximum visibility at all times. Make allowances for increased length and weight of the equipment when making turns, stopping the unit, etc.



**THIS SYMBOL MEANS:  
ATTENTION!  
BECOME ALERT!  
YOUR SAFETY IS  
INVOLVED!**

**TAKE NOTE! THIS SAFETY ALERT SYMBOL FOUND THROUGHOUT THIS MANUAL IS USED TO CALL YOUR ATTENTION TO INSTRUCTIONS INVOLVING YOUR PERSONAL SAFETY AND SAFETY OF OTHERS. FAILURE TO FOLLOW THESE INSTRUCTIONS CAN RESULT IN INJURY OR DEATH!**

### **SIGNAL WORDS**

Note use of following signal words **DANGER**, **WARNING**, and **CAUTION** with safety messages. The appropriate signal word for each has been selected using the following guidelines:

**DANGER:** Indicates an imminently hazardous situation that, if not avoided, will result in death or serious injury. This signal word is to be limited to most extreme situations typically for machine components which, for functional purposes, cannot be guarded.

**WARNING:** Indicates a potentially hazardous situation that, if not avoided, could result in death or serious injury, and includes hazards that are exposed when guards are removed. It may also be used to alert against unsafe practices.

**CAUTION:** Indicates a potentially hazardous situation that, if not avoided, may result in minor or moderate injury. It may also be used to alert against unsafe practices.

### **EQUIPMENT SAFETY GUIDELINES**

Every year many accidents occur which could have been avoided by a few seconds of thought and a more careful approach to handling equipment. You, the operator, can avoid many accidents by observing the following precautions in this section. To avoid personal injury, study the following precautions and insist those working with you, or you yourself, follow them.

Operator should be a responsible adult. **DO NOT ALLOW PERSONS TO OPERATE THIS UNIT UNTIL THEY HAVE DEVELOPED A THOROUGH UNDERSTANDING OF SAFETY PRECAUTIONS AND HOW IT WORKS.**

**DO NOT** modify the trailer in anyway. Doing so may impair the function and/or safety and could affect the life of the trailer.

Never exceed the maximum capacity of the trailer. By doing so you risk damage to your Demco trailer. If it's ability to do a job, or to do so safely is in question **DON'T TRY IT.**

Review safety instructions with all users annually.

Replace any caution, warning, danger or instruction safety decal that is not readable or is missing. Location of such decals is indicated in this booklet.

Do not paint over, remove, or deface any safety signs or warning decals on your equipment. Observe all safety signs and practice instructions on them.

**LOAD DISTRIBUTION SAFETY**

The total weight of the load you put on the trailer, plus the empty weight of the trailer itself, must not exceed the trailer's Gross Vehicle Weight Rating (GVWR). You must distribute the load on the trailer such that the load on any tire or axle does not exceed the tire load rating or the Gross Axle Weight Rating (GAWR). If you do not know the weight of your trailer you must weigh it at a commercial scale. See your VIN Plate for proper ratings. Not following these guidelines could cause serious injury or even death.

**TIRE AND LUG NUT SAFETY**

It is essential to inspect the trailer tires and wheels before each tow. Trailer tires are more likely to fail compared to car tires due to the heavier load the trailer carries. Please follow the list of guidelines and/or possibilities below that could cause serious injury or even death.

- Replace the tire before towing if the tire has a bald spot, cut, bulge, is showing any cords, or is cracked.
- If uneven tread is noticed, take the trailer to a dealer service center for an inspection. Tire imbalance, axle misalignment, or incorrect inflation could cause the uneven tread.
- Too little of tread will not be adequate enough for traction and can cause loss of control on wet highways.
- Tire pressure that is improper causes an unstable trailer and could blowout the tire causing loss of control.
- Check the tire pressure before towing, while the tire is cold. For the recommended PSI, see the VIN Plate or the side wall of the tire.
- Always order and install tires and wheels with appropriate type and load capacity to meet or exceed gross weight of unit.

The inspection of the tire and wheel lug nuts is necessary since they are prone to loosen after first being assembled. Please follow the list of guidelines and/or possibilities below that could cause serious injury or even death.

- When towing a new trailer, check the lug nuts after the first 50 to 100 miles of driving.
- Metal creep between the wheel and the lug nuts will cause wheel to loosen and could come off. Check to make sure the lug nuts are tight before each tow.
- Improper torque could cause the wheel to separate from trailer. A torque wrench should be used to tighten the lug nuts. If one is not available use a lug wrench then take to a trailer dealer or service garage to tighten them to the required torque.



**IMPORTANT:** Install new safety decals and reflectors if the existing ones are destroyed, lost, painted over or cannot be read. When parts are replaced that have decals or reflectors, be sure to install new decals/reflectors with each new part.

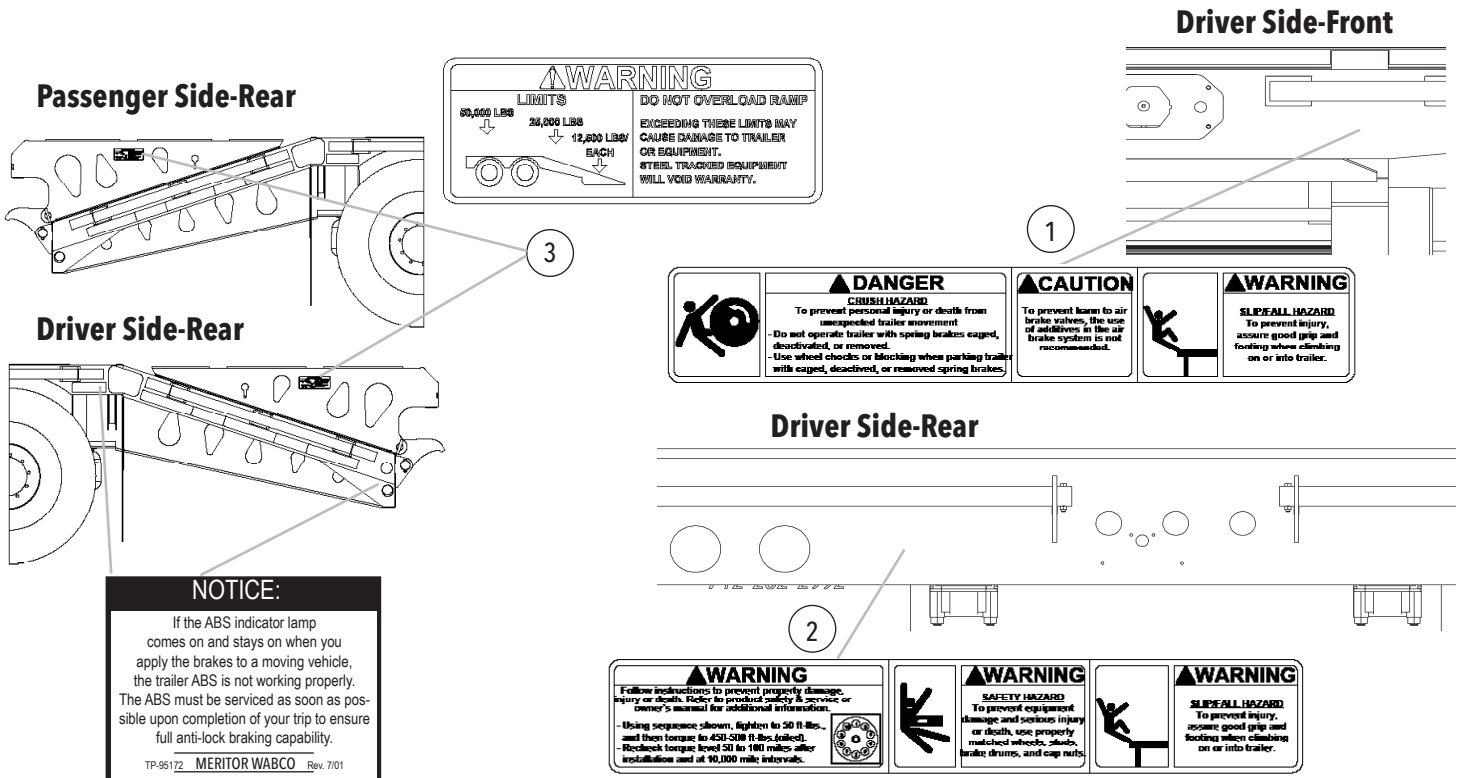

BOM ID	Qty	Item No	Description
1	1	1AQAL100000	DEEP ETCHED PLATE
2	1	1AQAL100009	GVW STICKER - DEMCO
3	1	1AQAL100010	5 x 7.5 CLEAR PROTECTIVE OVERLAY
4	3	1AQBC015065	GREASE GUN STICKER - RED SYMBOL ON WHITE BACKGROUND
5	1	1AQCA065000	LARGE TRAILER FRONT WALL DECAL
6	1	1AQCB065000	LARGE TRAILER REAR WALL DECAL
7	2	1AQLT06100	TRAILER WARNING
9	12'	1AQSAFEWALK	2" x 60' BLACK ANTI-SLIP TAPE
10	1	DE21003	MEDIUM SIZE RED DEMCO DECAL

### HOW TO APPLY SAFETY DECALS

1. Be sure that the installation area is clean and dry.
2. Be sure temperature is above 50°F(10°C).
3. Decide on exact position before removing the backing paper.
4. Remove smallest portion of split backing paper.
5. Align decal over specified area and carefully press the small portion with the exposed sticky backing in place.
6. Slowly peel back remaining paper and carefully smooth remaining portions of decal into place.
7. Small air pockets can be pierced with a pin and smoothed out using a piece of decal backing paper.

## BOLT TORQUE SPECIFICATIONS

Tighten all bolts to torques specified in chart unless otherwise noted. Check tightness of bolts periodically, using bolt chart as guide. Replace hardware with same grade bolt.

**NOTE:** Unless otherwise specified, high-strength Grade 5 hex bolts are used throughout assembly of equipment.



### TORQUE SPECIFICATIONS

Torque figures indicated are valid for non-greased or non-oiled threads and heads unless otherwise specified. Therefore, do not grease or oil bolts or cap screws unless otherwise specified in this manual. When using locking elements, increase torque values by 5%.

\* GRADE or CLASS value for bolts and cap screws are identified by their head markings.

Bolt Torque for Standard Bolts *						
"A"	GRADE 2		GRADE 5		GRADE 8	
	lb-ft	(N.m)	lb-ft	(N.m)	lb-ft	(N.m)
1/4"	6	(8)	9	(12)	12	(16)
5/16"	10	(13)	18	(25)	25	(35)
3/8"	20	(27)	30	(40)	45	(60)
7/16"	30	(40)	50	(70)	80	(110)
1/2"	45	(60)	75	(100)	115	(155)
9/16"	70	(95)	115	(155)	165	(220)
5/8"	95	(130)	150	(200)	225	(300)
3/4"	165	(225)	290	(390)	400	(540)
7/8"	170	(230)	420	(570)	650	(880)
1"	225	(300)	630	(850)	970	(1310)

Bolt Torque for Metric Bolts *						
"A"	CLASS 8.8		CLASS 9.8		CLASS 10.9	
	lb-ft	(N.m)	lb-ft	(N.m)	lb-ft	(N.m)
6	9	(13)	10	(14)	13	(17)
7	15	(21)	18	(24)	21	(29)
8	23	(31)	25	(34)	31	(42)
10	45	(61)	50	(68)	61	(83)
12	78	(106)	88	(118)	106	(144)
14	125	(169)	140	(189)	170	(230)
16	194	(263)	216	(293)	263	(357)
18	268	(363)	--	--	364	(493)
20	378	(513)	--	--	515	(689)
22	516	(699)	--	--	702	(952)
24	654	(886)	--	--	890	(1206)

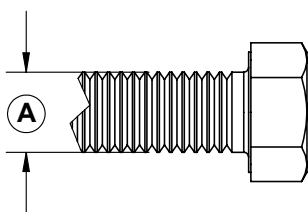

GRADE-2

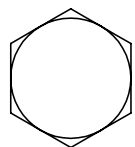

GRADE-5

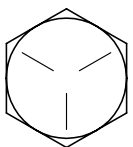

GRADE-8

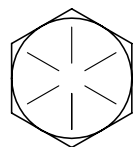

CLASS 8.8

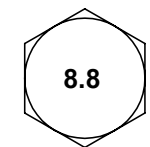

CLASS 9.8

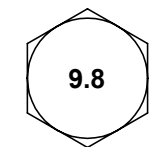

CLASS 10.9



It is extremely important to apply and maintain proper wheel mounting torque on your trailer axle. Torque is a measure of the amount of tightening applied to a fastener (nut or bolt) and is expressed as length times force. For example, a force of 90 pounds applied at the end of a wrench one foot long will yield 90 lbs-ft of torque. Torque wrenches are the best method to assure the proper amount of torque is being applied to a fastener.

**NOTE:** Wheel nuts or bolts must be applied and maintained at the proper torque levels to prevent loose wheels, broken studs, and possible dangerous separation of wheel from your axle.

Be sure to use only the fasteners matched to the cone angle of your wheel (usually 60 degrees or 90 degrees). The proper procedure for attaching your wheels is as follows:

1. Start all bolts or nuts by hand to prevent cross threading.
2. Tighten bolts or nuts in the following sequence.
3. The tightening of the fasteners should be done in stages. Following the recommended sequence, tighten fasteners per wheel torque requirements diagram:

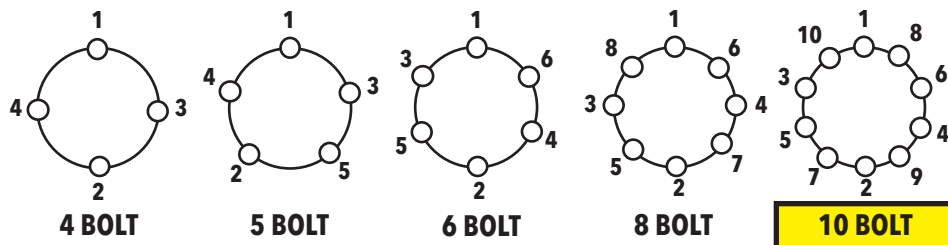

4. Wheel nuts or bolts should be torqued before first road use and after each wheel removal. Check and re-torque after the first 50 miles and again at 100 miles. Check periodically thereafter.

### WHEEL AND RIM TORQUE REQUIREMENTS

Description	Application	Minimum Torque	Maximum Torque
		(lbs-ft)	(lbs-ft)
1/2" Cone Nut	12" - 13" Wheel	50	65
	14" - 15" Wheel	90	120
5/8" Cone Nut	Flat Disc Wheel	175	225
3/4" Hex Nut	Demountable Ring Clamp	210	260
3/4" Spherical Nut	Single Wheel	450	500
	Inner Dual	450	500
1-1/2" Spherical Nut	Outer Dual	450	500
5/8" Flange Nut	Wheels	275	325

## Trailer Lights and Wiring

The lights and wiring system on every Demco Drop Deck Trailer meet or exceed all federal and state requirements in effect at the time of manufacture. Wherever required by law, lights and reflectors are marked by the manufacturer to indicate the appropriate specifications with which each complies.

For optimum performance and long life from the trailer's lights and wiring, follow this inspection procedure:

1. Clean all reflectors and lights. See that all lights burn properly. Replace all burned out lights and broken reflectors. Factory approved replacement parts should be used, and replacement bulbs of equal candle power should be used for safety.

**WARNING!** Use only a 12 volt DC battery for checking lights or anti-lock systems. Never use battery chargers or transformers.

2. Inspect all wiring to see that it is not frayed, and that it is properly supported and protected, with all connections tight.
3. See that the light cable is clean and long enough to permit jackknife parking. Be certain that the cable is supported so that it cannot be pinched or entangled by the lower and upper couplers.
4. Keep the 7-way plug on the light cable and the 7-way connector on the trailer free of corrosion.

**Junction Box** -- Demco Drop Deck Trailers use a Truck-Lite 88 sealed wiring harness. A 7-pole nose box is used in conjunction with the wire harness.

**Trailer Lights** -- The table below provides wire color codes for all trailers:

Yellow - Left Turn

Brown - Tail Lights

Green - Right Turn

White - Ground

Red - Stop Light

Blue - A.B.S

Black - Clearance, Cluster and License Plate

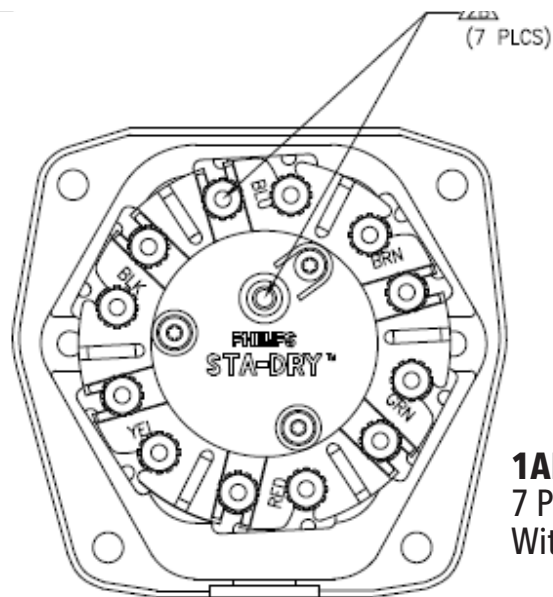

**1AEU0167609**  
7 Pole Nose Box  
Without Breakers



## Trailer Towing Tips

Driving a vehicle while towing a trailer is completely different from driving the same vehicle without a trailer. Acceleration, manipulation and braking are all reduced. It takes longer to get up to speed; you need more room to turn and pass, and more distance to stop. You will need to spend time adjusting to the different feel and maneuverability of the vehicle with a loaded trailer. Because of the considerable differences in all aspects of manipulation when towing a trailer, the dangers and risks of injury are also much greater than when driving without a trailer. You are responsible for keeping your vehicle and trailer in control, and for any damage that is caused if you lose control of your vehicle and trailer.

Before you start towing the trailer, you must follow all of the instructions for inspection, testing, loading and coupling.

Drive slowly at first, 5 m.p.h. or so, and turn the wheel to get the feel of how the vehicle and trailer combination responds. Next, make some right and left hand turns. Watch in your side mirrors to see how the trailer follows the vehicle. Turning with a trailer attached requires more room. Stop a few times from speeds no greater than 10 m.p.h. Try using different combinations of trailer/air brakes and vehicle brakes. Note the effect that the trailer brakes have when they are the only brakes used.

## Pre-Trip Checklist

**Perform the Pre-Trip Checklist whenever the vehicle and trailer have been left unattended.**

1. Beware of bystanders, particularly children. Always look around and make sure it is safe to move the tow vehicle and trailer. This is especially important in high noise areas, as you may not hear people. Make sure the vehicle tow rating is high enough for what is being towed.
2. Adjust vehicle mirrors so you can see the trailer and areas to the rear of it.
3. Check that the 5th wheel is properly coupled and locked. (See the next section in this manual for specific instructions on coupling and uncoupling the trailer.)
4. Check that the electric cord is properly connected to the trailer plug.
5. Walk around the trailer to check conditions of tires, lights and landing gear.
6. Check lug nuts and bolts for proper tightness.
7. Visually inspect trailer for any loose bolts, worn parts, or cracked welds, and make necessary repairs.

## Routine Checklist

**Perform a Routine Inspection Checklist before operating the vehicle and grain trailer.**

1. Perform the Pre-Trip Checklist.
2. Assure tires are inflated evenly.
3. Assure brakes are adjusted evenly.
4. Clean reflectors and lights and check that they are working properly.
5. Check coupler tightness after towing 50 to 100 miles.

### Visual Inspection

For safe operating conditions and longer component life make these visual inspections before the trailer is released for work.

**Remember the Department of Transportation mandates you do this inspection.**

**1. Check the angle of the chassis.**

To get conditions for least tire wear, a loaded trailer must travel parallel to the highway. A level angle of the chassis permits correct wheel chamber without toe-in or toe-out.

**2. Check the tires.**

The tires of each dual wheel must be matched to a minimum of 0.125" (3.2 mm) of the same rolling radius and a minimum of 0.75" (19 mm) of the same rolling circumference. The tires also must have equal air pressures.

**3. Check the brake drums and linings.**

Both wheel ends of each axle must have the same type of lining and drum equipment. Both tandem axles also must have the same kind of lining and drum equipment.

**4. Check the thickness of the brake lining.**

The thickness of the brake lining must be the same on each shoe of the brake and on each side of the axle.

**5. Check the brake system.**

Apply the brake and check for air leaks at the brakes, air tanks, hoses and valves. When the brakes are applied, the brake shoes must move quickly and the lining must press against the drum. When the brakes are released, the brake shoes must retract fully.

**6. Check for leaking lubricant at the wheel ends.**

Leaking lubricant is caused by worn or damaged seal, or wrong gasket or seal installation.

**NOTE:** Always follow the brake lining specifications supplied by vehicle manufacturer.



## Safety Guidelines

Carefully study and understand the Operator's Manual and all safety decals before operating, servicing, adjusting or repairing. It is the owner/operators responsibility to read the manual and instruct other operators to read the manual before operating.

- Always follow state and local regulations regarding safety chains and auxiliary lighting when towing.
- Keep hands, feet, hair & clothing away from moving and/or rotating parts.
- Do not carry passengers anywhere on the trailer.
- In addition to the design and configuration of a trailer, hazard control and accident prevention are dependent upon the knowledge, concern, and common sense of personnel involved in the operation, transportation, maintenance and storage of the trailer.
- Practice the operations and functions of your trailer. Don't hurry the learning process or take it for granted.
- Untrained operators are not qualified to operate the trailer.
- If the operation safety is followed, along with a good maintenance program your trailer will provide you with years of trouble-free service.

## Operating Safety

- Always drive at a safe speed, and slow enough to make an emergency stop if necessary.
- With ideal road conditions follow the posted speed limit but do not exceed 60 mph.
- Do not drive so fast that the trailer begins to sway due to speed.
- Allow plenty of stopping distance for the vehicle and trailer.
- Allow plenty of room for passing. A rule of thumb is that the passing distance with a trailer is four times the passing distance without a trailer.
- Use vehicle mirrors to verify enough room to change lanes or pull into traffic.
- Use turn signals well in advance.
- Shift your automatic transmission into a lower gear for city driving.
- Be extra careful on inclines. Use lower gears for climbing and descending grades.
- Do not ride the brakes while descending grades; they may get so hot that they stop working. You can potentially have a runaway vehicle and trailer.
- To conserve fuel, don't use full throttle to climb a hill. Instead, build speed on the approach.
- Slow down for bumps in the road. Take your foot off the brake when crossing the bump.
- Do not brake while in a curve unless absolutely necessary. Instead, slow down before you enter the curve and power through the curve. This way, the towing vehicle remains "in control."
- Do not apply the brakes to correct extreme trailer swaying. Continued pulling of the trailer, and even slight acceleration, will provide a stabilizing force.
- When halting operations, even periodically, set towing vehicle's parking brake, shut off engine, and remove the ignition key, to prevent unauthorized operation.
- Secure wheels when trailer is not being used.



### Service and Maintenance

Carefully read this section on trailer service and maintenance safety. Good maintenance is your responsibility. Performing maintenance according to the schedule will prolong the performance and life of your trailer and ensure the safety and liability of the operation. If you cannot perform the required maintenance talk to your dealer about having them done. Also check the relevant component manufacturer's manual if available.

- Make sure there is plenty of ventilation. Never operate engine of towing vehicle in a closed building. Exhaust fumes may cause asphyxiation.
- Always block wheels and never use a jack as sole support.
- Always use proper tools or equipment for job at hand.
- Use extreme caution when making adjustments.
- Follow torque chart in this manual when tightening bolts and nuts.
- Openings in skin and minor cuts are susceptible to infection from brake fluid.
- After servicing, be sure all tools, parts and equipment are removed
- Do not allow grease or oil to build up on any step or platform.
- When replacing bolts, refer to owner's manual for proper size and grade.
- Refer to bolt torque chart for head identification marking.
- When replacement parts are necessary for periodic service & maintenance, genuine factory replacement parts must be used to restore your trailer. Manufacturer will not claim responsibility for use of unapproved parts and/or accessories or other damages.
- If the trailer has been altered in any way from original design, any liability for injury or warranty will not be accepted by Demco.
- A fire extinguisher and first aid kit should be kept accessible while performing any service and maintenance on the trailer.

### Cleaning the Trailer

It is imperative trailers constructed of steel be kept clean of salt and other harmful elements. Failure to wash your trailer regularly and properly care for the paint and body may void any paint warranty claims if the trailer shows signs of neglect or abuse.

When cleaning the trailer use a mild soap and rinse. Wash underneath both slope areas, kingpin, and suspension areas.

Keeping your trailer clean will help rid your trailer of salt and other harmful elements. This will help keep your trailer looking new and improve its resale value.

## Care of Wood Decking for Platform Trailers

**Below are some recommendations from our decking manufacturer. Following these recommendations will extend the life of the wood decking.**

Platform trailers that sit idle for periods of time are exposed to elements where they may suffer weather damage. This damage results from excessive sunlight, temperature and/or moisture. The damage from sunlight and high temperatures may take the form of shrinkage to the top face of the decking causing larger than normal spacing to appear between boards. Often this will be accompanied by concave cupping of the decking, which is more pronounced in wider width pieces, and cracking or splitting of the decking known as season checking. Such cracks may cause other problems. The cracks fill with rainwater and absorption of water in to wood can lead to degradation as trapped water penetrates the interior portion of the boards.

Prevention of weather damage can be greatly minimized by applying a good water repellent and UV-inhibitor to all visible surfaces of the decking. The cost of labor to apply the treatment and the material itself is modest when compared to the degradation from weather elements. It takes less than an hour's labor and approximately four gallons of repellent using a hand held roller or, the more preferred, hand held pump up sprayer to apply protection to the flooring.

Some of the various types of products used today are Thompson's and Baer's Waterseal, boiled linseed oil, Penofin and Wood Guard by ISK Biosciences of Memphis, TN. Any of these products will help increase the life of trailer decking. Incorporating a maintenance program of coating the decking on platform trailers will greatly benefit end users, dealers and manufacturers, especially in the event that trailers set idle for lengthy periods of time.

Best results when utilizing UV-inhibitors and water repellents are experienced when products are applied twice annually - spring and fall. This prepares the wood decking for the onslaught of excessive sunlight during summer months and extreme condition during winter months. Also, a liberal coating upon receipt of trailer will begin the process of limiting the affects of the environment.

Keep in mind that wood is a product of nature and, as such, will acclimate to its surrounding environment. Properly seasoned decking can change dimensions after installation given the right conditions. It is important to understand that excessive swings in environmental changes such as summer and winter will take their toll on decking. In addition, platforms setting dead lined or idle, are subject to a different environment than those in operation even if they are in identical locations. Remember the old adage "an ounce of prevention is worth a pound of cure". If you have any questions or would like more information, please contact your local dealer or OHC at 800-999-7616.



### Coupling Tractor - Semitrailers



#### **WARNING:**

Incorrect coupling and uncoupling can result in serious injury or death.

Knowing how to couple and uncouple correctly is basic to safe operation of combination vehicles. General coupling and uncoupling steps are listed below. There are differences between different trucks, so learn the details of coupling and uncoupling the truck(s) you will operate.

#### **Step 1 Inspect Fifth Wheel**

- Check for damaged/missing parts.
- Check to see that mounting to tractor is secure, no cracks in frame, etc.
- Be sure that the fifth wheel plate is greased as required. Failure to keep the fifth wheel plate lubricated could cause steering problems because of friction between the tractor and the trailer.
- Check if fifth wheel is in proper position for coupling.
  - Wheel tilted down towards rear of tractor.
  - Jaws open.
  - Safety unlocking handle in the automatic lock position.
- If you have a sliding fifth wheel, make sure it is locked.
- Make sure the trailer kingpin is not bent or broken.

#### **Step 2 Inspect Area and Chock Wheels**

- Make sure area around the vehicle is clear.
- Be sure the trailer spring brakes are on.
- Check that cargo is secured against movement due to tractor being coupled to the trailer.

#### **Step 3 Position Tractor**

- Pull the tractor directly in front of the trailer. (Never back under the trailer at an angle. This could push the trailer sideways and break the landing gear.)
- Check position using outside mirrors and looking down both sides of the trailer.

#### **Step 4 Back Slowly**

- Back until fifth wheel just touches the trailer.
- Don't hit the trailer.

#### **Step 5 Secure Tractor**

- Put on the parking brake.
- Put transmission in neutral.

#### **Step 6 Check Trailer Height**

- The trailer should be low enough that it is raised slightly by the tractor when the tractor is backed under it. Raise or lower the trailer as needed. (If trailer is too low, tractor may strike and damage nose of trailer; if trailer is too high, it may not couple correctly.)
- Check that the kingpin and fifth wheel are aligned.

#### **Step 7 Connect Air Lines to Trailer**

- Check glad hand seals and connect tractor supply (emergency/red) air line to trailer supply (emergency/red) glad hand.
- Check glad hand seals and connect tractor control (service/blue) air line to trailer control (service/blue) glad hand.
- Make sure air lines are safely supported where they won't be crushed or caught while tractor is backing under the trailer.

**Coupling Tractor -  
Semitrailers  
Continued****Step 8 Supply Air to Trailer**

- From cab, push in "air supply" knob or move tractor protection valve control from the "emergency" to the "normal" position to supply air to the trailer brake system.
- Wait until the air pressure is normal.
- Check brake system for crossed air lines.
- Shut engine off so you can hear the brakes.
- Apply and release trailer brakes, listen for sound of trailer brakes being applied and released. You should hear the brakes move when applied and air escape when the brakes are released.
- Check air brake system pressure gauge for signs of major air loss.
- When you are sure trailer brakes are working, start engine.
- Make sure air pressure is up to normal.

**Step 9 Lock Trailer Brakes**

- Pull out the "air supply" knob, or move the tractor protection valve control from "normal" to "emergency."

**Step 10 Back Under Trailer**

- Use lowest reverse gear.
- Back tractor slowly under trailer to avoid hitting the kingpin too hard.
- Stop when the kingpin is locked into the fifth wheel.

**Step 11 Check Connection for Security**

- Raise trailer landing gear slightly off ground.
- Pull tractor gently forward while the trailer brakes are still locked onto the tractor.
- Check and make sure that the trailer is locked onto the tractor.

**Step 12 Secure Vehicle**

- Put transmission in neutral.
- Put parking brakes on.
- Shut off engine and take key with you so someone else won't move truck while you are under it.
- Make sure air and electrical lines will not hit any moving parts of the vehicle.

**Step 13 Inspect Coupling**

- Use a flashlight if necessary.
- Make sure there is no space between upper and lower fifth wheel. If there is space, something is wrong (kingpin may be on top of closed fifth wheel jaws; trailer would come loose very easily).
- Go under trailer and look into the back of the fifth wheel. Make sure the fifth wheel jaws have closed around the shank of the kingpin.
- Check that the locking lever is in the "lock" position.
- Check that the safety catch is in position over locking lever. (On some fifth wheels, the catch must be put in place by hand.)
- If the coupling isn't right, don't drive the coupled unit; get it fixed.

### Coupling Tractor - Semitrailers Continued

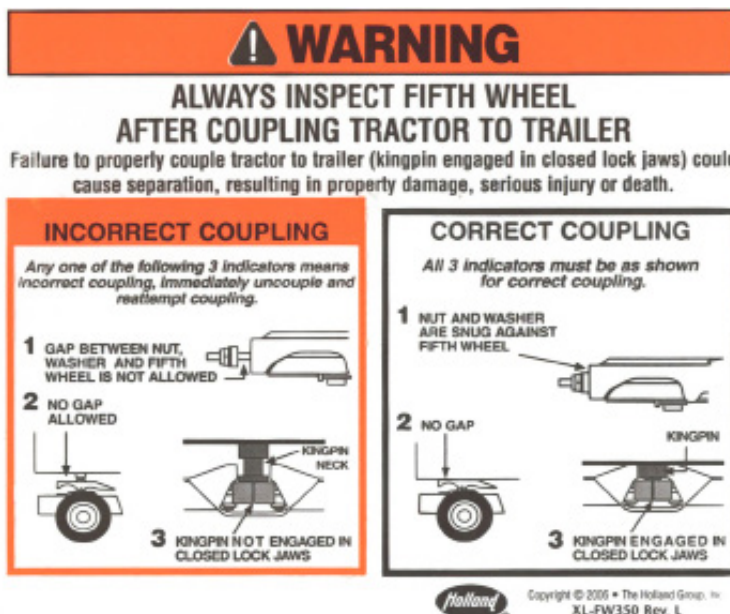

#### Step 14 Connect the Electrical Cord and Check Air Lines

- Plug the electrical cord into the trailer and fasten the safety catch.
- Check both air lines and electrical line for signs of damage.
- Make sure air and electrical lines will not hit any moving parts of the vehicle.

#### Step 15 Raise Front Trailer Supports (Landing Gear)

- Use low gear range (if so equipped) to begin raising the landing gear. Once free of weight, switch to the high gear range.
- Raise the landing gear all the way up. (Never drive with landing gear only part way up as it may catch on railroad tracks or other things.)
- After raising the landing gear, secure the crank handle safely.
- When full weight of trailer is resting on tractor:
  - Check for enough clearance between rear of tractor frame and landing gear. (When tractor turns sharply, it must not hit landing gear.)
  - Check that there is enough clearance between the top of the tractor tires and the nose of the trailer.

## Uncoupling Tractor - Semitrailers

The following steps will help you to uncouple safely.

### Step 1 Position Tractor and Trailer

- Make sure surface of parking area can support weight of trailer.
- Have tractor lined up with the trailer. (Pulling out at an angle can damage landing gear.)

### Step 2 Ease Pressure on Locking Jaws

- Shut off trailer air supply to lock trailer brakes.
- Ease pressure on fifth wheel locking jaws by backing up gently (this will help you release the fifth wheel locking lever).
- Put parking brakes on while tractor is pushing against the kingpin. This will hold rig with pressure off the locking jaws.

### Step 3 Lower the Landing Gear

- If trailer is empty – lower the landing gear until it makes firm contact with the ground, turn crank in low gear a few extra turns; this will lift some weight off the tractor. (Do not lift trailer off the fifth wheel.) This will:
  - Make it easier to unlatch fifth wheel;
  - Make it easier to couple next time.

### Step 4 Disconnect Air Lines and Electrical Cable

- Disconnect air lines from trailer. Connect air line glad hands to dummy couplers at back of cab, or couple them together.
- Hang electrical cable with plug down to prevent moisture from entering it.
- Make sure lines are supported so they won't be damaged while driving the tractor.

### Step 5 Unlock Fifth Wheel

- Raise release handle lock.
- Pull the release handle to "open" position.
- Keep legs and feet clear of the rear tractor wheels to avoid serious injury in case the vehicle moves.

### Step 6 Pull Tractor Partially Clear of Trailer

- Pull tractor forward until fifth wheel comes out from under the trailer.
- Stop with tractor frame under trailer (prevents trailer from falling to ground if landing gear should collapse or sink).

### Step 7 Secure Tractor

- Apply parking brake.
- Place transmission in neutral.

### Step 8 Inspect Trailer Supports

- Make sure ground is supporting trailer.
- Make sure landing gear is not damaged.

### Step 9 Pull Tractor Clear of Trailer

- Release parking brakes.
- Check the area and drive tractor clear.

## WABCO iABS™ Trailer ABS System with PLC

The Demco Drop Deck Trailers are equipped with WABCO iABS™ Trailer ABS System with PLC (Power Line Carrier). The 2S/1M Single Valve Assembly is used on our 1 Axle ABS Systems and the 4S/2M Dual Valve Assembly is used on our 2 Axle ABS Systems. (The 2S/1M includes two wheel sensors and one ABS modulator valve. The 4S/2M configuration includes four wheel sensors and two ABS modulator valves.)

WABCO's iABS Trailer ABS is an electronic, self-monitoring system that works with standard air brakes. The major components of the system are the Electronic Control Unit (ECU)/Valve Assembly, External ABS Modulator Valve (for 3M systems), Tooth Wheel and Wheel Speed Sensor.

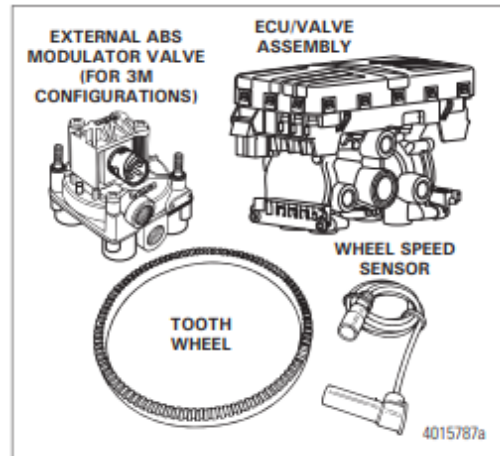

Please refer to the online WABCO Maintenance Manual at [https://www.wabco-customercentre.com/catalog/docs/mm19001\\_web.pdf](https://www.wabco-customercentre.com/catalog/docs/mm19001_web.pdf) for detailed information regarding System Configurations, Diagnostics, Sensor Adjustment & Component Testing, Troubleshooting, and Component Replacement.

### iABS™ TRAILER ABS SYSTEM WITH PLC AND CAN 2S/1M, 2S/2M, 4S/2M AND 4S/3M STANDARD/PREMIUM



MM19001

WABCO

## WABCO iABS™ Trailer ABS System with PLC

To identify the iABS System, check the identification tag on the Electronic Control Unit (ECU). The part numbers for the iABS System are:

- 400 500 320 0 (2S/1M Standard)
- 400 500 420 0 (2S/2M, 4S/2M Standard)

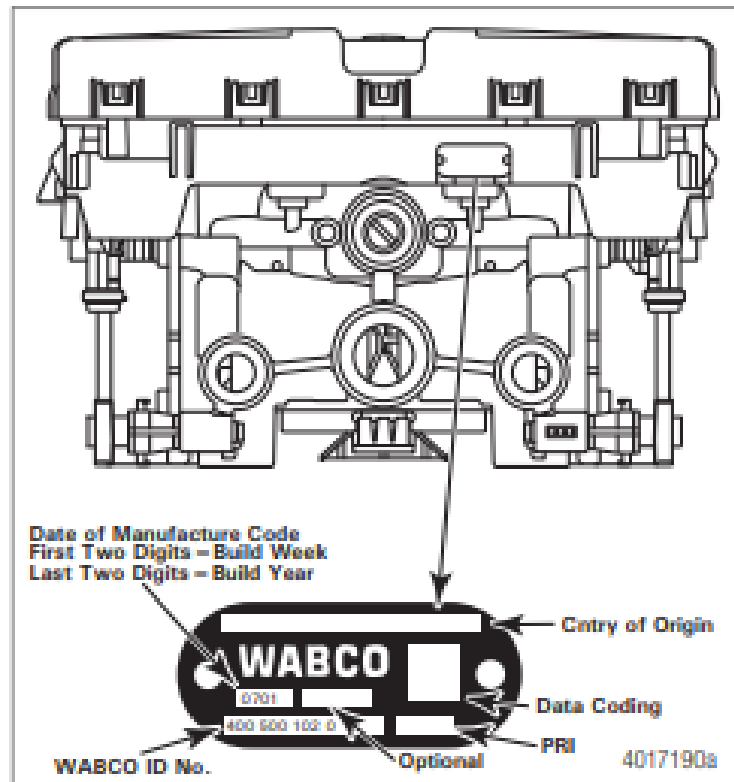

If you are not able to identify the version and need to request service literature, please visit [wabco-na.com](http://wabco-na.com).

Otherwise, contact WABCO Customer Care at 855-228-3203

## BRAKING WITH ABS

Do what good drivers have always been doing: brake just the way you always have. Apply brakes as normal to stop in time. When your ABS starts working, don't release your brakes, maintain brake pressure.

- If driving with a single trailer, doubles or triples...  
Watch your trailer(s) through your mirrors and correct brake pressure as necessary to keep in a straight line.
- If only your tractor has ABS...  
Use your rig's brakes as necessary to straighten out your trailer if it swings out. Watch the trailer through your mirrors to make sure it follows your tractor properly.
- If only your trailer has ABS...  
Use your rig's brakes as necessary to maintain control and keep your combination in its lane.

Avoid rapid "pumping" of the brakes. During a brake application that could result in a wheel lock. Meritor WABCO ABS automatically releases and applies the brake up to five times per second, obviously much faster than you could do pumping the brake pedal.

Always remember that you are the most important element in the safe operation of your vehicle. ABS is not an excuse to take unnecessary risks. Always drive carefully and stay a safe distance away from the vehicle in front of you.

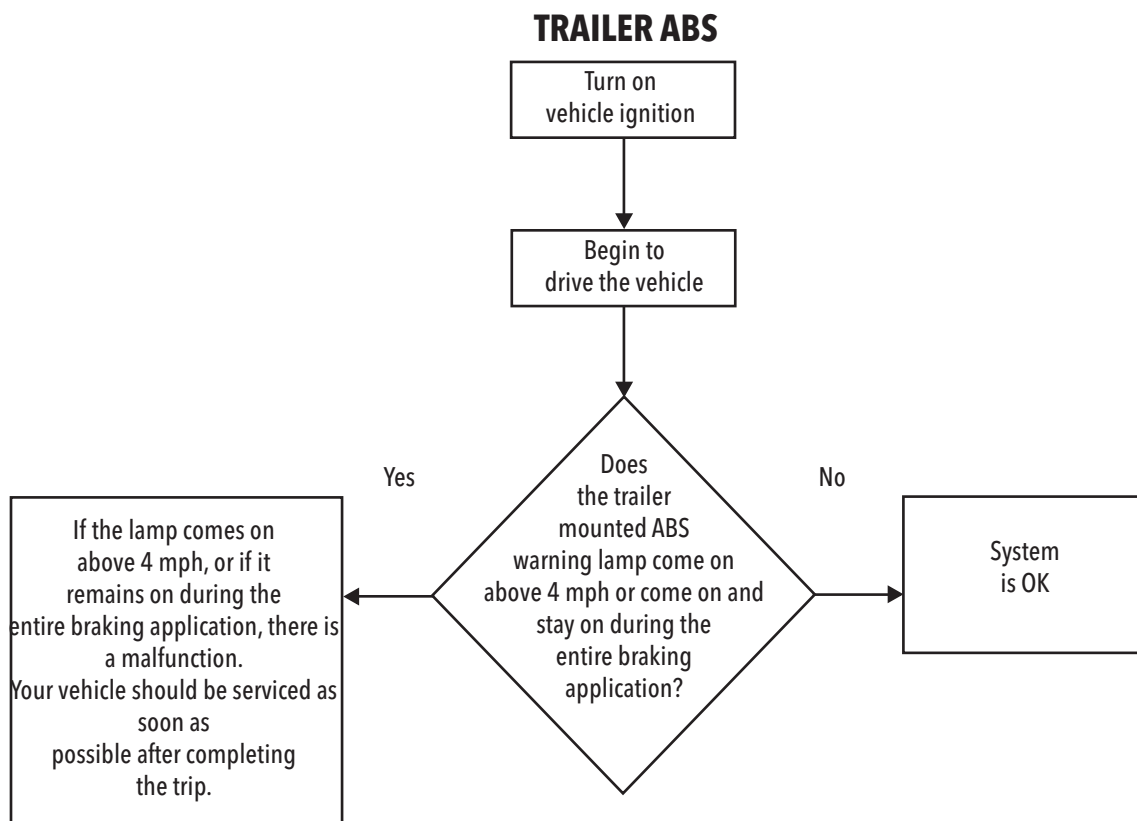

**NOTE: Depending how the ABS is powered, the lamp may come on briefly at ignition and then go off, or briefly flash each time you apply the brakes on a moving vehicle.**

## Operating Instructions

Demco uses the SAF-Holland - Atlas™ 55 model landing gear as standard equipment. The landing gears are designed to meet all AAR M-931 and all TTMA RP-4 performance specifications.

### Landing Gear Operation:

1. Push the crank handle in for high speed.
2. Pull the crank handle out for low speed.
3. Turn the crank clockwise to retract the leg.
4. Turn the crank counter-clockwise to extend the leg.
5. Crank storage hanger should be located on right-hand side of leg center line.
6. Always stow handle in hanger while in low gear (pull out).

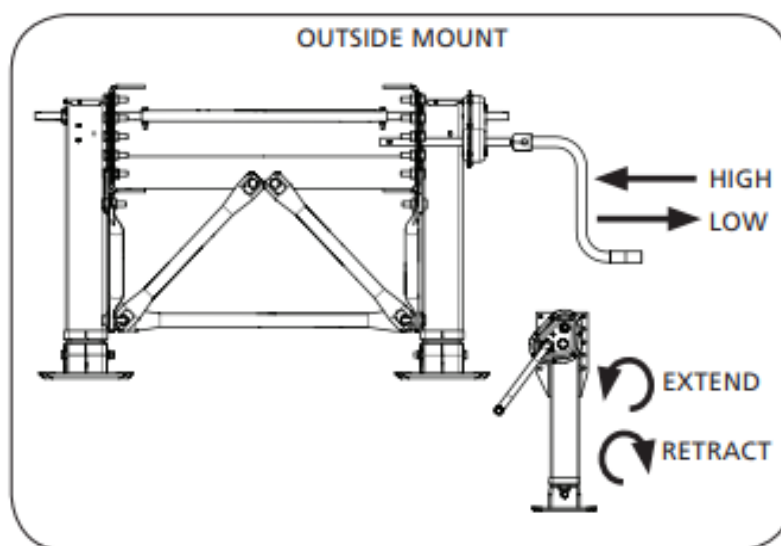

### To Connect Tractor To Trailer:

1. Ensure that the trailer is at a sufficient height to allow coupling of the tractor and trailer.
2. Connect air lines from tractor to trailer, then lock trailer brakes and back tractor under trailer, then lock fifth wheel.
3. Retract landing gears to fully retracted position before moving the trailer.
4. Store crank on the crank holder.
5. Remove chock blocks, if applicable.

### To Remove Tractor From Trailer:

1. Position the trailer so that the landing gear shoes rest on a firm level surface to prevent sinking into the soil or soft asphalt when landing gear is extended.
2. Always use chock blocks or lock trailer brakes when uncoupling or coupling the tractor and trailer on the road or in the terminal area. Chock as required for unusual conditions.
3. Shift landing gear to high gear and extend landing gear until shoes contact ground.
4. Shift landing gear to low gear and lift trailer approximately 1 inch.
5. Unlock fifth wheel, uncouple air lines, and drive tractor out from under trailer.



When operating the landing gears, it is necessary to observe some cautions. By doing so, you will ensure long trouble free service.

1. Do not over extend or over retract landing gears.
2. Never drop trailer on landing gears. Always extend landing gears until sand shoes contact ground, then lift trailer approximately 1 inch before removing tractor from trailer.
3. Always ensure that landing gear shoes or foot pads will rest on a hard ground surface or concrete pad. If necessary, place shoes on a support plank to prevent the landing gears from sinking into the ground surface. (This is especially important with liquid cargo where a shift in the contents could overturn the trailer.)
4. Always retract landing gears fully before moving the trailer.
5. Always store the crank on the crank holder after extending or retracting the landing gear.
6. Replace all damaged or missing parts.
7. Failure to replace worn or damaged riser nut and retracting screw assembly could cause a failure.

### Maintenance Procedures

#### **Lubrication -- Standard:**

When manufactured, the landing gears have been adequately greased with high quality lubricant. It will be necessary to periodically supplement this lubricant to maintain satisfactory performance. Use a grease with the appropriate temperature range for your operating conditions. Gearbox leg has (3) grease fittings; leg without gearbox has (2) grease fittings.

1. Prior to lubrication, extend legs approximately (2) inches from maximum retracted position.
2. For optimum performance, every (6) months lube both legs at all grease fittings.
3. Add 1/4-lb grease at each grease fitting.

#### **Lubrication -- NoLube™:**

No additional grease is required.

#### **Additional Maintenance, Routine Service Schedule & Troubleshooting**

For additional maintenance, routine service schedule, and troubleshooting, refer to the online SAF-HOLLAND Atlas 55 Manual at:

<https://www.intermodal.org/documents/SAFHolland-Atlas.pdf>

**Hutch 9700 Series**

Demco Drop Deck Trailers are equipped with the Hutch 9700 Series spring ride suspension with underslung configuration from Hutchens Industries. They have a Gross Axle Weight Rating (GAWR) of 22,400 lbs. when equipped with single leaf, two leaf, and standard three leaf springs. The Heavy-Duty three leaf springs raise the GAWR to 25,000 lbs.

Hutchens provides several online resources at:  
[hutchensindustries.com/9700-series/](http://hutchensindustries.com/9700-series/)



**Product Resources**

Catalog Section	+ Warning Decals
Installation Instructions	+ Engineering Drawings
+ Maintenance	Warranty
+ Product Documentation	Suspension Spec Sheet

Should you need assistance, the "Catalog Section" includes parts and configuration information, as well as instructions on how to order.

**For additional assistance, please feel free to contact Hutchens Industries at: 1-800-654-8824.**



**Hutchens Industries**  
 The Difference is Durability. The Quality is Hutchens.

## Recommended Maintenance from Hutchens

### Warning

We strongly emphasize that the maintenance procedures that we will discuss have a significant safety purpose. Failure to maintain proper torque values on each of the suspension fasteners can result in a failure of suspension components. Further, use of any visibly worn or damaged component can result in a failure. A failure can result in loss of vehicle control and personal injury or death. Safety is the number one concern at Hutchens Industries. We urge you to follow the maintenance procedures set out in our video and in these written instructions.

The first step of a maintenance check is the visual inspection. Walk around the trailer and inspect all suspension components and attachment welds for any problems, such as cracks or unexpected wear. If a component has damage, replace it with a new Genuine Hutch component.

Any threaded connection found to be damaged, rusted, seized or with excessive corrosion that could affect the torque on the fasteners should not be reused. Replace with new Hutch components. Also, if you notice any abnormal tire wear or if the trailer is "off-tracking" this could suggest an alignment issue that may have been the result of inadequate fastener maintenance. Make sure to check all fasteners anytime there is a question about axle alignment.

Review the Hutchens torque decal for the appropriate torque values for each suspension fastener. The lubricated/coated torque values in the first column are for new fasteners with lubricated and coated threads. When you are installing new Hutch components, we recommend you lubricate the threads and use the torque values in this column. For maintenance checks on fasteners that have been in service, use the higher torque values in the dry thread column.

Maintaining the proper torque on the bolts and nuts is necessary to ensure that unintended joint movement that can lead to excessive suspension wear does not occur.

While a visual inspection is critical to identify obvious defects, **you cannot rely on your visual inspection to determine how tight a fastener is.**

Use a **torque wrench** to check all bolts and nuts to ensure that the recommended torque values are being maintained.

After the first maintenance check, routine visual inspections, torque checks and alignments should be performed at regular intervals throughout the life of the trailer. This is in addition to all federal, state, and industry inspection and maintenance requirements and guidelines.

**ANY THREADED CONNECTION FOUND TO BE RUSTED AND SEIZED OR WITH EXCESSIVE CORROSION THAT COULD AFFECT THE TORQUE ON THE FASTENERS SHOULD NOT BE REUSED. REPLACE WITH NEW COMPONENTS.**

**WARNING**

**FOLLOW ALL TORQUE REQUIREMENTS. FAILURE TO PROPERLY TORQUE FASTENERS COULD LEAD TO LOSS OF VEHICLE CONTROL AND RESULT IN SERIOUS INJURY OR DEATH**

**Install all new fasteners with clean lubricated threads using Lubricated/Coated torque values below. Coated fasteners are considered lubricated. For fasteners that have been in service, use Dry torque values. Check all fasteners regularly to maintain proper torque levels.**

Size	Application	Lubricated/Coated	Dry
1 1/8"	Rocker Bolts	590-708 lb-ft	790-948 lb-ft
1"	9700 Radius Rod Bolts	540-648 lb-ft	720-864 lb-ft
7/8"	U-Bolts and 9600 Radius Rod Bolts	350-420 lb-ft	470-564 lb-ft
3/4"	U-Bolts	310-340 lb-ft	420-460 lb-ft
5/8"	Radius Rod Clamp Bolts	130-156 lb-ft	170-204 lb-ft
5/8"	Spring Retainer Bolts	35-42 lb-ft	50-60 lb-ft
5/8"	Pin Cage Bolts	180-216 lb-ft	240-288 lb-ft
1/2"	Hold Down Clip Bolts	65-78 lb-ft	85-102 lb-ft

**Hutchens Industries**

P.O. Box 1427  
Springfield, MO 65801-1427  
Tel Free 1-800-654-8824

9700/9600 Suspensions and Sliders  
Decal P/N 16086-01 Rev K

Hutchens Torque Decal Part No. 16086-01

This decal should be installed on the side of the trailer in a visible location. Decals can be obtained free of charge by contacting Hutchens Industries, Inc.

**Demco Part Number  
1AQWA076000**

**Note:** Although a conventional overslung axle configuration is shown, these recommendations apply to ALL axle sizes and configurations. Also, these checks and recommended fastener torques apply to ALL cast and fabricated steel hanger styles and wheel bases.

Now let's look closely at the maintenance requirements for each of the suspension's main component groups.

## Axle Clamp Group and Springs

1. Check the torque on the U-bolt nuts by alternately tightening opposing corners of the clamp assembly. See Fig. 1.
  - a. When using 7/8" U-bolts, the torque on the nuts should be maintained at a **dry** level of 470 – 564 lb-ft.
  - b. When using 3/4" U-bolts, the torque on the nuts should be maintained at a **dry** level of 420 – 460 lb-ft

Fig. 1

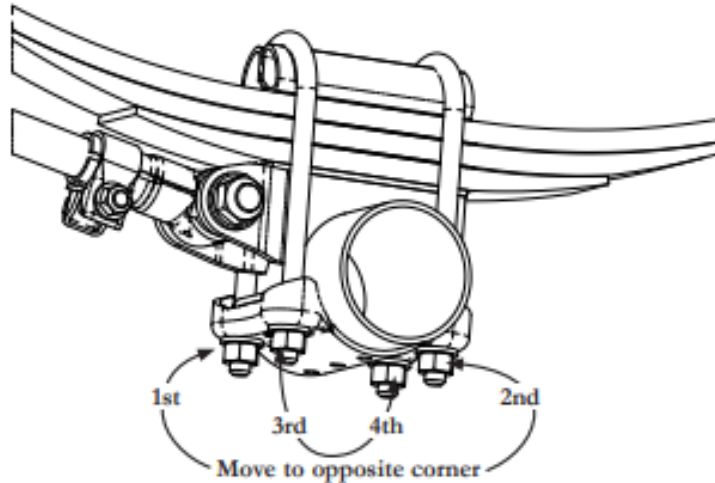

Always carefully examine the spring and axle clamp components for any signs of wear or cracks and replace if visible wear or cracks are present.

## Radius Rods

- 2a. If you are working on the 9700 model suspension - The 1" radius rod attachment bolts at the hangers and spring seats should be maintained at a **dry** torque level of 720 – 864 lb-ft. This applies to both the adjustable and non-adjustable radius rods. See Fig. 2a.

Fig. 2a

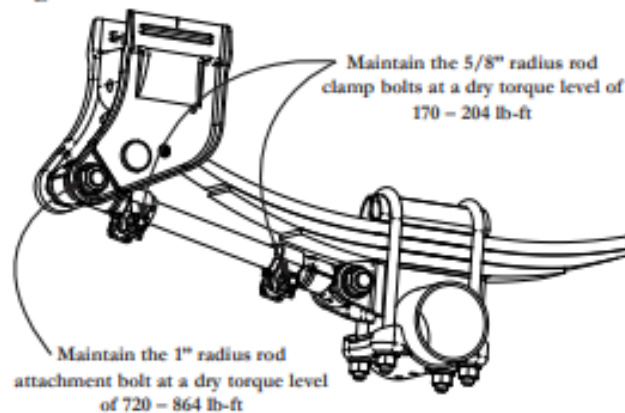
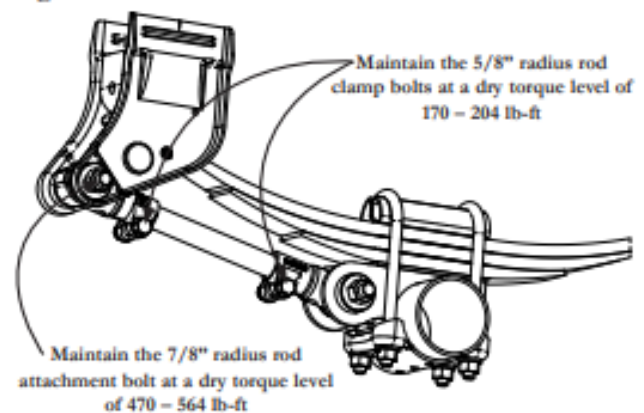

Fig. 2b



- 2b. If you are working on the 9600 model suspension - The 7/8" radius rod attachment bolts at the hangers and spring seats should be maintained at a **dry** torque level of 470–564 lb-ft. See Fig. 2b.

Loose operation of the radius rod bolts can result in wear requiring that new Hutch components be installed to avoid structural damage. During your visual inspection, if you observe any wear or loosening in the bushing, it is imperative that you immediately replace the radius rod bushing and bolt. Failure to replace these components will result in damage to the hanger, spring seat and/or the radius rod.

- 2c. Next check the 5/8" radius rod clamp bolts. These bolts should be maintained at a **dry** level of 170 - 204 lb-ft of torque. See Figures 2a. and 2b. If the clamp bolt has not been properly maintained, then wear between the adjustable radius rod screw and the eye end will occur. If so, the entire radius rod must be replaced. **Simply re-tightening the clamp bolt or replacing it will not correct the problem.**

## Rocker Bushings

If the center rocker/hanger connections are not installed with the Huck® bolt fasteners, the single 1 1/8" rocker bolt should be maintained at a dry level of 790 – 948 lb-ft of torque for both the 9600 and 9700 model suspensions. See Figures 3a. and 3b.

Fig. 3a

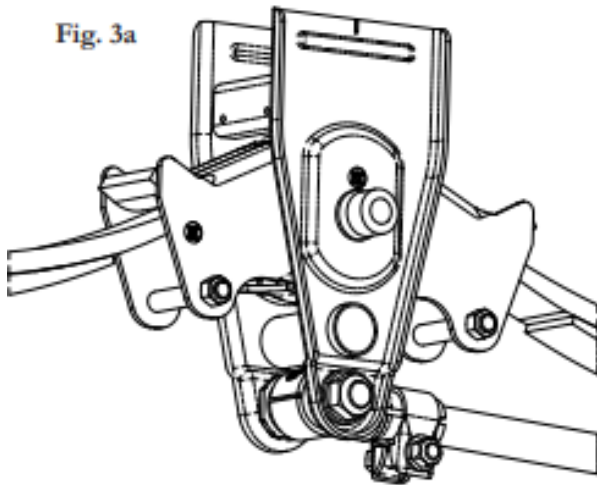

Huck® Bolt  
No torque maintenance required

Fig. 3b

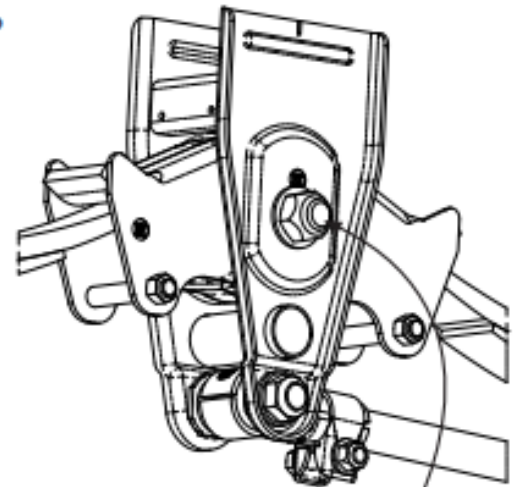

Maintain the single 1 1/8" rocker bolt  
at a dry torque level of 790 – 948 lb-ft

During your check if the Huck® fastener or rocker bolts are loose, a detailed inspection of the rocker is important to ensure that no structural damage has occurred.

## Hangers

Finally, check all of the 5/8" spring retainer bolts found in the rockers and rear hangers.

A dry torque value of 50 - 60 lb-ft should be maintained on all of these bolts. Be careful not to overtighten the retainer bolts. See Fig. 4

Fig. 4

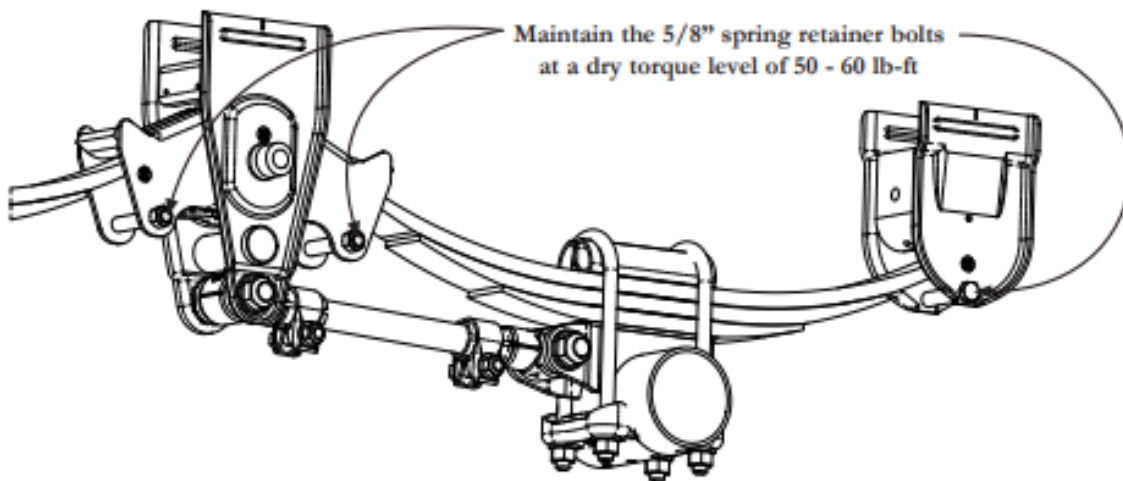

Remember, loose fasteners that are allowed to operate for any period of time will result in irreversible suspension damage and possible loss of vehicle control. **Simply re-tightening a worn fastener will not correct the situation created by loose operation!** So maintain the proper torque levels and enjoy the long life and dependability of a Hutch suspension.

Following any maintenance procedures or repairs, the trailer's axle alignment should be examined and adjusted to comply with the Truck and Trailer Manufacturers Association (TTMA) Recommended Practice RP No. 71 and The Maintenance Council (TMC) Recommended Practice RP 708D.

**SAF-Holland CBXu Series**

Demco Liquid Tender Trailers with air ride suspensions are equipped with the CBXu Series with fixed frame underslung configuration from SAF-Holland.

SAF-Holland provides several online resources with the most current product information at: [www.safholland.com/us](http://www.safholland.com/us)

Should you need assistance, the "download-center" includes a search field for instructions and manuals. The **Maintenance Manual for SAF CBXu Series** is part number **xl-as20010MM-en-US**.

The SAF Routine Maintenance and Troubleshooting sections are included (with manufacturer permission) on the next pages. For more detailed information on standards, adjustments, alignments, parts replacement, etc., please refer to the SAF-Holland online manual for the most up-to-date product information.

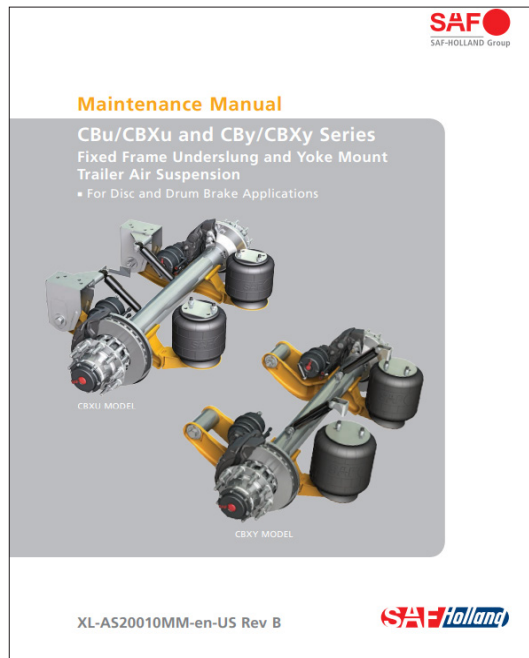

**For additional assistance, please feel free to contact SAF-Holland at: 1-888-396-6501.**

SAF-HOLLAND USA, INC.  
1950 Industrial Blvd., Muskegon, MI 49442  
[www.safholland.com](http://www.safholland.com)



### 21. Routine Maintenance and Daily Inspection

1. Daily or before each trip, check the suspension to be sure it is fully operational.
2. Inspect all decals to ensure they are clearly legible and intact. Clean with a terry cloth towel, soap and water.
3. Visually inspect air springs for sufficient inflation and that the suspension is at proper ride height. For ride height details and measurements, refer to Section 7 of this manual.

#### 21.1 Initial Three (3) Months or 5,000 Mile (8,000 km) Service Inspection

1. Suspension ride height (underside of frame to centerline of axle) **MUST** be within  $\pm 1/4"$  (6 mm) of recommended design height. For instructions on measuring ride height, refer to Section 7.

**CAUTION** An improperly set ride height could result in suspension component damage and/or poor vehicle ride performance.

2. After the first three (3) months or 5,000 miles (8,000 km) of service, whichever comes first, inspect the bolts and nuts at the pivot connections to ensure they are properly torqued. Check all other nuts and bolts for proper torque or that the spline is sheared off. Refer to the specifications listed in Section 20. Re-torque as necessary thereafter.
3. With the vehicle on a level surface and air pressure above 85 psig (5.9 bars), verify that all air springs are of sufficient and equal firmness.

**NOTE:** Check all air control system fittings for air leaks, by applying a soapy water solution and checking for bubbles at all air connections and fittings.

#### 21.2 Routine Physical Inspections

Every 100,000 Miles (160,000 km) or one (1) year, whichever comes first.

Check all other suspension components for any sign of damage, looseness, torque loss, wear or cracks. Repair, tighten or replace damaged part(s) to prevent equipment breakdown.

#### 21.3 Visual Inspection Procedure

**IMPORTANT:** A schedule for physical and visual inspections should be established by the operator based on severity of operation or damage to the vehicle could occur.

**IMPORTANT:** During each pretrip and safety inspection of the vehicle, a visual inspection of the suspension should be done or damage to the vehicle could occur.

Visually check for:

- Loose, broken or missing fasteners. Repair or replace as needed.

**WARNING** Loose, damaged, or missing fasteners can cause loss of vehicle control which, if not avoided, could result in death or serious injury.

- Air springs – clearances, wear damage, and proper inflation.
- Shock absorbers – leaking or damaged.
- Cracked parts or welds.

Troubleshooting



22. Troubleshooting

PROBLEM	POSSIBLE CAUSE	RESOLUTION
All air springs flat (no air)	Insufficient air pressure to suspension	Make sure air pressure is in excess of 85 psig (5.9 bars).
		Test and verify that the air pressure protection valve is functioning properly using the instructions in Sections 8 and 9. Replace if necessary.
		Inspect and verify that the height control valve is functioning properly by following the inspection procedures in Section 9.
		Check air compressor, refer to manufacturer's service manual.
Air springs deflate rapidly when vehicle is parked	Air leakage from the suspension air system or the air brake system	Test for air leakage from loose fittings or damaged air lines, air springs, brake actuators or height control valve – apply a soapy water solution to the connections and air springs, if necessary, and check for bubbles (leaks). Tighten loose fittings to stop leakage and/or replace worn or damaged parts.
	Air leakage from the suspension air system	Test for air leakage from loose fittings between air tank and air suspension or damaged air lines, air springs or height control valve – apply a soapy water solution to connections and air springs, if necessary, and check for bubbles (leaks). Tighten loose fittings to stop leakage and/or replace worn or damaged parts with new ones.
Air springs ruptured	Tire, tire rim or brake component rubbing air spring	Check inside to inside tire dimension. There MUST be 1" (25.4 mm) minimum clearance around air spring. If not, it may be necessary to re-install the suspension. Install tire rim back spacers to provide more clearance.
	Spring brake chamber rubbing air spring	Re-locate chamber or rotate clamp ring for more clearance.
Air spring failed	Continual or repeated over-extension of the air spring	Visually inspect for broken or loose shock absorber or shock absorber mounting bracket. Re-connect loose parts and replace any defective parts. Check the adjustment of the height control valve, refer to Section 7.
	Air spring(s) worn out	Replace air spring(s), refer to Section 13.
	Air leak or damaged line	Check air spring for punctured or leak and replace with proper air spring, check for proper clearance around air spring, 1" (25.4 mm) minimum.
		Test for air leakage from damaged air lines – apply a soapy water solution to the air lines and connections and check for bubbles (leaks). Tighten loose fittings to stop leakage and/or replace worn or damaged parts.
	Restricted air line(s) between the height control valve and the air spring(s)	Disconnect the height control valve linkage and rotate the actuating lever to the 20° down position. If the air spring(s) remain inflated, check for pinched or blocked line(s).
"Temporary Operation"	If attempts to repair air loss have failed to correct the problem, disconnect the height control valve linkage and exhaust all air from the system. Cautiously drive at a reduced speed to the nearest repair facility. An internal rubber bumper built into the air spring will make it possible to temporarily operate the vehicle without air pressure.	
Ride height too high or too low	Height control valve out of adjustment	Re-adjust the height control valve, refer to the height control valve adjustment procedures in Section 7.
Front pivot connection worn and loose	Fixed frame bracket pivot wear washers worn	Replace worn internal wear washers and realign axles.
	SwingAlign™ pivot alignment plates worn	Replace worn alignment plates and realign axles, refer to Section 19.
	Front pivot bolt loose	Tighten front pivot bolt connection. Replace all worn or damaged components, refer to Section 15 and 16.
	Excessive lateral axle walk – 3/4" (19 mm) is maximum	Re-weld axle connection, refer to Section 6 for welding specifications. Replace worn front pivot connection bushing with proper service repair kit. For proper kit, refer to SAF-HOLLAND® Aftermarket Parts Manual. For replacement procedures, refer to Section 15 and 16.
Shock absorber failures	Over-extending shock absorbers	Re-adjust height control valve to proper suspension ride height, refer to Section 7.
		Check suspension specification sheet to verify mounting height, or refer to Section 7 for correct ride height and adjustment procedure.
		Replace shock absorber(s) with correct length and/or proper replacement, refer to Section 14.
Excessive tire wear	Loose or worn bushings at pivot connection	Check pivot connection bushings for damage, wear and/or loose components. Replace damaged or worn components, refer to Section 15 and 16 tighten loose connections to proper torque specification, refer Section 20. For proper service repair kit, refer to SAF-HOLLAND® Aftermarket Parts Manual.
		Check axle alignment and re-align, if necessary.
	Suspension NOT properly installed	Contact SAF-HOLLAND® Service Department and/or the trailer manufacturer to address improper suspension installation.

### SAF-Holland INTEGRAL® Disc Brake Axles

Demco Liquid Tender Trailers with disc brake axles are equipped with the INTEGRAL® Disc Brake Axles with Compact Bearing System from SAF-Holland.

SAF-Holland provides several online resources with the most current product information at: [www.safholland.com/us](http://www.safholland.com/us)

Should you need assistance, the "download-center" includes a search field for instructions and manuals. The **Service Manual for INTEGRAL® Disc Brake Axles with Compact Bearing System** is part number **XL-SA100590M-en-US**.

The SAF Routine Service Schedule and Troubleshooting sections are included (with manufacturer permission) on the next pages. For more detailed information on parts, inspections, wheels, tests, installation procedures, torque charts, etc., please refer to the SAF-Holland online manual for the most up-to-date product information.



**For additional assistance, please feel free to contact SAF-Holland at:  
1-888-396-6501.**

SAF-HOLLAND USA, INC.  
1950 Industrial Blvd., Muskegon, MI 49442  
[www.safholland.com](http://www.safholland.com)

**SAF-Holland**  
Engineering Your Road to Success



### 13. Routine Service Schedule

**⚠️WARNING** Failure to inspect and maintain your SAF-HOLLAND® INTEGRAL® disc brake axle as outlined in Section 12 can result in brake or wheel bearing failure which, if not avoided, could result in death or serious injury.

**⚠️WARNING** Failure to maintain your SAF-HOLLAND® INTEGRAL® disc brake with SAF-HOLLAND® Original Parts can result in brake or wheel bearing failure which, if not avoided, could result in death or serious injury.

**IMPORTANT:** Use only SAF-HOLLAND® Original Parts to service your SAF-HOLLAND® INTEGRAL® disc brake axle.

WHICHEVER OCCURS FIRST	PERIODIC CHECKS				
	MILEAGE INTERVALS	After First 3,000 Miles	Daily	Every 20,000 Miles	Every 50,000 Miles
		TIME INTERVALS		After First Month	Every 3 Months
<b>VISUAL AND SAFETY INSPECTION</b>					
Inspect for missing, or loose hubcap.			•		
Inspect for grease leakage around hubcap.			•		
Hub unit maintenance-free. Check for grease leaks. Refer to Section 8.				•	
Inspect the brake caliper guide system. Check for free movement and stalling action. Refer to Section 5.3.					•
Check rubber dust covers for cracks and damage. Check adjuster cap for correct seating. Refer to Section 5.3.					•
Inspect brake pad thickness regularly. Refer to Section 5.				•	
Inspect brake rotors for cracks. Refer to Section 5.					•
Perform general service / maintenance inspection. Refer to Section 4.		•			
Perform disc brake / hub unit inspection. Refer to Section 5.		•			•
Perform wheel rock and wheel noise tests. Refer to Section 6 and 7.				•	

**MECHANICAL CHECK**  
 Attention: Check torque of wheel nuts after the first 5-100 miles (8-160 km) from date vehicle was placed into service and after every wheel removal. Continually check wheel torque every 10,000 miles (16,000 km), or at the intervals indicated in your vehicle owner's manual, whichever occurs first.

<b>SPECIAL SERVICE CONDITIONS</b>	
Vehicles with long standing periods.	Service at specified time intervals, e.g. trailer used for storage or frequently left standing for several days at a time.
Vehicles used under severe duty and extreme conditions.	Service at suitably reduced intervals, e.g. trailer operating in continuous multi-shifts or in off-road construction sites.

**14. Troubleshooting Chart (SAF-HOLLAND® suspensions equipped with disc brake axles)**

PROBLEM	POSSIBLE CAUSE	POSSIBLE REMEDY
<b>Brakes will NOT release</b>	<b>Disc brake caliper bound up</b>	<b>Lubricate or replace brake caliper</b>
	Brake hoses restricted	Replace hoses
	<b>Brake control valve restricted/inoperable</b>	<b>Repair/replace control valve</b>
	Brake out of adjustment	Adjust brake/repair or replace automatic adjustment device as necessary
	<b>Damaged brake chamber</b>	<b>Replace brake chamber</b>
	Damaged brake assembly	Replace or repair brake assembly
	<b>Supply air interrupted</b>	<b>Open glad hand cut-out cock or push brake control valve in</b>
	Supply line improperly coupled	Properly couple supply air line
<b>Brake pads freeze to rotor in cold weather</b>	<b>Warm brakes</b>	
<b>No brakes or insufficient brake performance</b>	Service air interrupted	Open glad hand cut-out cock
	<b>Service air line improperly coupled</b>	<b>Properly couple service air line</b>
	Brake hoses restricted	Relieve restriction or obstruction or replace hoses
	<b>Brake control valve restricted/inoperable</b>	<b>Repair/replace control valve</b>
	Brake out of adjustment	Adjust brake/repair or replace automatic adjustment device as necessary
	<b>Damaged brake chamber</b>	<b>Replace brake chamber</b>
	Damaged brake assembly	Replace or repair brake assembly
<b>Dragging Brakes/Slow brake application or release timing</b>	<b>Brake hoses restricted</b>	<b>Relieve restriction or obstruction or replace hoses</b>
	Brake control valve restricted/inoperable	Repair/replace control valve
	<b>Brake out of adjustment</b>	<b>Adjust brake/repair or replace automatic adjustment device as necessary</b>
	Damaged brake chamber	Replace brake chamber
	<b>Damaged brake assembly</b>	<b>Replace or repair brake assembly</b>
<b>Dog tracking</b>	Axle not properly aligned	Align axle
	<b>Slider assembly racked or NOT aligned properly</b>	<b>Repair or replace slider assembly</b>
	Frame bent or NOT aligned properly	Repair or align frame
	<b>Damaged suspension component</b>	<b>Repair or replace suspension component</b>
	Bent axle	Replace axle
<b>Uneven tire wear</b>	<b>Improper tire inflation</b>	<b>Inflate tire to proper pressure</b>
	Loose wheel stud nuts	Inspect for and repair any resultant wheel end damage and tighten properly
	<b>Improper wheel bearing adjustment</b>	<b>Inspect for and repair any resultant wheel end damage and adjust properly</b>
	Axle NOT properly aligned	Align axle
	<b>Slider assembly racked or NOT aligned properly</b>	<b>Repair or replace slider assembly</b>
	Frame bent or NOT aligned properly	Repair or align frame
	<b>Damaged suspension component</b>	<b>Repair or replace suspension component</b>
	Bent axle	Replace axle
	<b>Mis-matched tire sizes</b>	<b>Properly match tire sizes</b>
	Unequal brake balance or timing	Repair brakes as necessary
	<b>Overly aggressive braking</b>	<b>Instruct/train driver in proper brake use</b>
	High speed turns	Instruct/train driver in proper vehicle speeds
	<b>High level of side scrub</b>	<b>Instruct/train driver in proper vehicle maneuvering</b>
	Anti-Lock Brake System malfunction	Refer to ABS manufacturer's service literature

PROBLEM	POSSIBLE CAUSE	POSSIBLE REMEDY
Grabbing brakes	<b>Contaminants on brake lining</b>	<b>Replace brake pads</b>
	Brake out of adjustment	Adjust brake/repair or replace automatic adjustment device as necessary
	<b>Warped brake rotor</b>	<b>Machine or replace brake rotor</b>
	Damaged brake chamber	Replace brake chamber
	<b>Damaged brake assembly</b>	<b>Replace or repair brake assembly</b>
	Unequal brake balance or timing	Repair brakes as necessary
	<b>Air-Lock Brake System malfunction</b>	<b>Refer to ABS manufacturer's service literature</b>
Excessive heat cracks in rotor	Brake out of adjustment	Adjust brake/repair or replace automatic adjustment device as necessary
	<b>Overly aggressive braking</b>	<b>Instruct/advise driver in proper brake use</b>
	Unequal brake balance or timing	Repair brakes as necessary
	<b>Air-Lock Brake System malfunction</b>	<b>Refer to ABS manufacturer's service literature</b>
	Damaged brake chamber	Replace brake chamber
	<b>Damaged brake assembly</b>	<b>Replace or repair brake assembly</b>

### SAF-Holland INTEGRAL® Drum Brake Axles

Demco Liquid Tender Trailers with drum brake axles are equipped with the INTEGRAL® Drum Brake Axles from SAF-Holland.

SAF-Holland provides several online resources with the most current product information at: [www.safholland.com/us](http://www.safholland.com/us)

Should you need assistance, the "download-center" includes a search field for instructions and manuals. The **Service Manual for INTEGRAL® Drum Brake Axles** is part number **XL-TA100060M-en-US**.

The SAF Routine Service Schedule and Troubleshooting Chart are included (with manufacturer permission) on the next pages. For more detailed information on parts, hubs, seals, bearings, inspections, installation, adjustments, etc., please refer to the SAF-Holland online manual for the most up-to-date product information.



**For additional assistance, please feel free to contact SAF-Holland at:  
1-888-396-6501.**

SAF-HOLLAND USA, INC.  
1950 Industrial Blvd., Muskegon, MI 49442  
[www.safholland.com](http://www.safholland.com)

**SAF-Holland**  
Engineering Your Road to Success



21. Routine Service Schedule

WHICHEVER OCCURS FIRST		PERIODIC CHECKS		
MILEAGE INTERVALS	AFTER FIRST 3,000 MILES	EVERY 10,000 MILES	EVERY 50,000 MILES	EVERY 100,000 MILES
TIME INTERVALS	AFTER FIRST MONTH	EVERY MONTH	EVERY 6 MONTHS	EVERY 12 MONTHS
<b>VISUAL INSPECTION FOR WEAR/DAMAGE</b>				
Check brake linings for wear.	■	■		
Check S-Camshaft for proper operation.	■	■		
Check brake adjusters for correct function.	■	■		
Check air brake system for leaks (brake applied).	■	■		
Check axle structural components for cracks or damage.	■	■		
Check hub lubrication level for excessive leakage.	■	■		
<b>MECHANICAL CHECK</b>				
Attention: Torque check wheel nuts after the first 5-100 miles (8-160 km) from date vehicle was placed into service and after every wheel removal. Continuously check wheel torque every 10,000 miles (16,000 km), or at the intervals indicated in your vehicle owner's manual, whichever occurs first.	■			
Torque check all nuts and bolts to recommended setting.	■		■	
Check and adjust wheel bearing end play.	■			■
Pack hub bearings with fresh lubricant (also after every brake lining replacement, check hub bearing wear).				■
Lubricate S-Camshaft bearing bushings.	■	■		
<b>SAFETY INSPECTION</b>				
Check brake lining to drum clearance for correct adjustment – re-adjust clearance if necessary. Check service brake and parking brake for performance.	■	■		
<b>SPECIAL SERVICE CONDITIONS</b>				
Vehicles with long standing periods.	Service at specified time intervals, e.g. trailer used for storage or frequently left standing for several days at a time.			
Vehicles used under extreme conditions.	Service at suitably reduced intervals, e.g. trailer operating in continuous multi-shifts or in off-road construction sites.			

Warranty claims will only be accepted as long as the operation and maintenance instructions have been complied with and if SAF-HOLLAND approved spare parts have been fitted.

23. Troubleshooting Chart

PROBLEM	POSSIBLE CAUSE	RESOLUTION
<b>Brakes will not release</b>	<b>Brake shoes bound up at anchor pins</b>	<b>Lubricate brake operating parts</b>
	Brake hoses Restricted	Replace hoses
	<b>Brakes out of adjustment</b>	<b>Adjust brakes</b>
	Damaged brake assembly	Replace or repair as required
No brakes or insufficient brakes  NOTE: All of the possible causes would result in brake lockup.	<b>Source of air supply shut off at tractor</b>	<b>Open cutoff cocks at rear of tractor cab or push control valve "IN"</b>
	Low brake line pressure	Check air pressure gauge on tractor - inoperative
	<b>Brake lines between tractor and trailer not properly coupled</b>	<b>Properly couple brake lines</b>
	Reservoir drain cock open	Close drain cock
<b>Dog tracking</b>	<b>Leaf spring broken</b>	<b>Replace complete spring</b>
	Bent Axle	Replace or straighten axle
	<b>Frame or suspension out of alignment</b>	<b>Straighten frame or align axles</b>
Uneven tire wear	Over or under inflation	Inflate to proper pressure
	<b>Loose wheel stud nuts or clamps</b>	<b>Tighten wheel stud nuts or clamps</b>
	Loose or tight wheel bearing adjustment	Adjust bearings
	<b>Axle bent or out of alignment</b>	<b>Straighten, align or replace axle</b>
	Tires not properly matched	Match tires
	<b>Improper acting brakes</b>	<b>Correct brakes as required</b>
	Rapid Stopping	Apply brakes slowly when approaching stop
	<b>High speed driving on turns</b>	<b>Reduce speed</b>
<b>Grabbing brakes</b>	Oil, grease or foreign material on brake lining	Reline brakes
	<b>Brakes out of alignment</b>	<b>Adjust brakes</b>
	Brake drum out-of-round	Replace brake drum
	<b>Damaged brake chamber or internal assembly</b>	<b>Replace brake chamber/internal assembly</b>
	Leaky or broken hose between relay valve and brake chamber	Replace or Repair as required
Excessive heat cracks on drum	<b>Rapid stopping or poor air flow to brakes</b>	<b>Replace drum</b>
	Out of adjustment	Adjust brakes
	<b>Missing S-Cam, anchor pins or chamber seal and pin</b>	<b>Lubricate and fire up</b>
	Damaged brake assembly/brake drum out-of-round	Replace or repair as required
<b>ABS inoperative</b>		<b>Refer to ABS manufacturer's service literature</b>
Slow brake application or release	Lack of lubrication	Lubricate brake operating parts
	<b>Excessive travel in brake chamber push rod</b>	<b>Adjust brakes</b>
	Restriction in hose or lines	Replace hoses
	<b>Defective brake valve</b>	<b>Replace brake valve</b>

## LUBRICATION GUIDE

### Wheel-End Lubrication

This section provides information on lubricating Meritor trailer axle wheel-ends with oil.  
Figure 14.2.

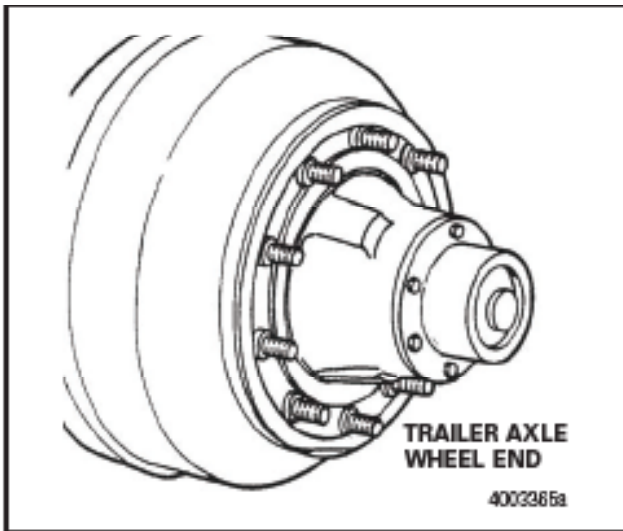

Figure 14.2

### Oil Lubricated

1. The most common oils used in Meritor trailer axle wheel-ends have a designation of API-GL-5 (American Petroleum Institute - Gear Lubricant No. 5). This oil is also approved under military specification MIL-2105D. Refer to Table L in this section.
2. In addition to the GL-5 oils listed, oils with API grades GL-1, GL-2, GL-3 and GL-4 can also be used in trailer axle wheel-ends. These oils cannot be used in drive axles, or any application which employs hypoid, amboid, spiral, bevel, or planetary gearing.
3. Oil viscosity should be suitable for the climate in which the axle will be operated.
  - a. Low viscosity single grade gear oils, such as SAE 75W (Society of Automotive Engineers), should only be used in cold climates. Oil seals must be in excellent condition when using low viscosity oils to insure against loss of these thin fluids.
  - b. Multigrade oils, such as 80W/90, should be used where vehicles operate in both warm and cold climates.
4. Do not use thinning agents such as kerosene, gasoline, or other solvents that lower the viscosity of lubricants.
5. The recommended frequency of wheel-end oil changes depends on such factors as environment, speeds, and loads imposed on axle. For example, applications such as container chassis service put limited stress on wheel-end lubricant, allowing maintenance intervals to be extended. Other applications, such as off-highway dump trailer service, put severe stress on the wheel-end lubricant, requiring that maintenance be performed more frequently. The following information is therefore intended as a general guideline:
  - a. General - Change oil whenever it is contaminated or when wheel-end cavity is disrupted by removing spoke wheel or hub.
  - b. Standard-Duty Service - For standard-duty on-highway service, change oil every 100,000 miles or 12 months, whichever comes first.
  - c. Heavy-Duty Service - For heavy-duty on-highway, off-highway or combined on/off highway service, change oil every 30,000 miles or 6 months, whichever comes first.
6. Guidance for lubricating a wheel-end with approved gear oil (Table L) is as follows:
  - a. Coat bearing cones with oil.
  - b. Apply a light film of NLGI #1 or #2 grease (not oil) to axle spindle bearing journals to help protect them from fretting corrosion. Figure 14.3.

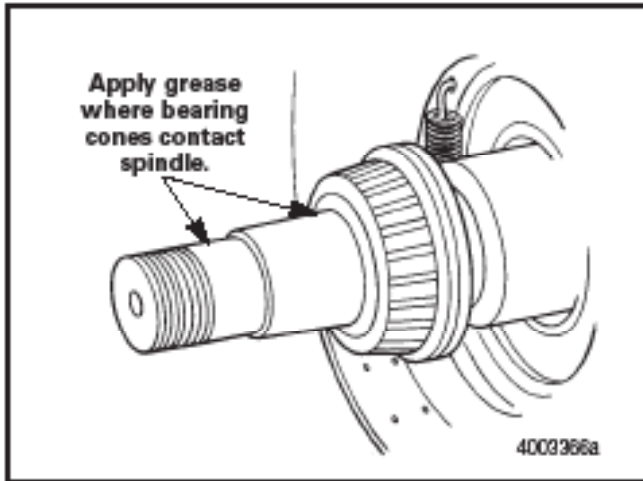

Figure 14.3



**CAUTION**

**It is important not to overfill the wheel-end cavity with lubricant. Wheel-end oil level should never exceed the middle of the hubcap. Also, make sure any excess oil is wiped away since it can contaminate brake linings and cause poor brake performance.**

- c. Fill wheel-end with an approved gear oil to hubcap fill line. Note that oil must be given sufficient time to settle prior to final check of oil level. This is especially important in cold conditions. Figure 14.4.

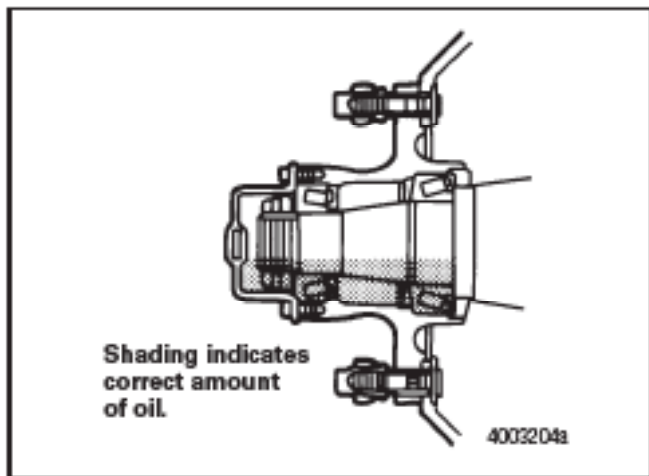

Figure 14.4

**Ramp Hinges**

Generously grease ramp hinges monthly. This will help to force moisture and dirt from the hinges.

- 7. Inspect wheel-end oil level at least every 1,000 miles (1,600 km). To check, make sure vehicle is on level ground then clean hubcap window and observe oil level. Add lubricant if oil level is down more than 0.25 inch (6.3 mm) from fill line. Figure 14.5.

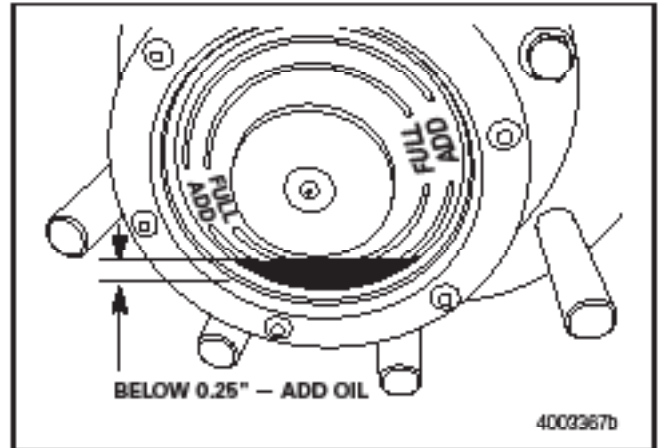
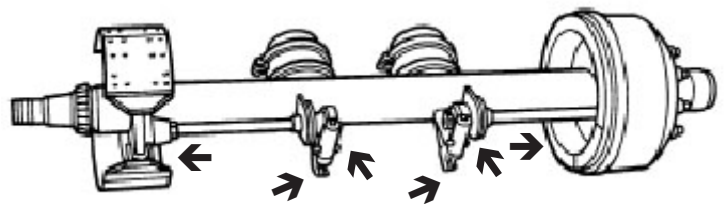

Figure 14.5

**Greasing the Axle**

On each axle there are six grease zerks that need to be greased every six months or every 10,000 miles. The grease zerks are located by the arrows shown below.



**CAUTION**

**Make sure any excess grease or oil is wiped away since it can contaminate brake linings and cause poor brake performance. If necessary, clean the disc or the drum and replace contaminated linings.**

**Conventional Trailer Axle Wheel-End Lubrication Intervals and Specifications**

**Table 1: Conventional Trailer Axle Wheel-End Oil Change Intervals and Specifications**

Check Oil Level	Oil Change*	Mortor Specification	Specification Approval	Oil Description	Operating Temperature			
					°F		°C	
					Min.	Max.	Min.	Max.
1,000 miles (1600 km)	<p><b>Light and General Service:</b> For 100,000 miles (160,000 km) or more a year, change the oil every 100,000 miles (160,000 km). For less than 100,000 miles (160,000 km) a year, change the oil once a year.</p> <p><b>Heavy Service:</b> For 80,000 miles (128,000 km) or more a year, change the oil every 30,000 miles (48,000 km). For less than 80,000 miles (128,000 km) a year, change the oil every six months.</p> <p><b>Conditions That Require an Oil Change:</b> Change the oil if the wheel end is disturbed during wheel or hub removal or if the oil is contaminated.</p>	O-7B-A Gear Oil	<p>MIL-PRF-210 5-E and SAE J2360</p>	GL-5 SAE 85W/140	-10	None	-12	None
		O-7B-D Gear Oil		GL-5 SAE 80W/90	-15	None	-20	None
		O-7B-E Gear Oil		GL-5 SAE 75W/90	-40	None	-40	None
		O-7B-J Gear Oil		GL-5 SAE 75W	-40	35	-40	2
		O-7B-L Gear Oil		GL-5 SAE 75W/140	-40	None	-40	None
		O-7B-M Full-Synthetic Gear Oil		GL-5 SAE 75W/140	-40	None	-40	None
		O-7B-N Full-Synthetic Gear Oil		GL-5 SAE 75W/90	-40	None	-40	None
		O-81 Full-Synthetic Oil		SAE 60	-40	None	-40	None

\*The recommended oil change interval is based on operating conditions, mileage, speed and load. Limited service applications may allow the recommended interval to be increased. Severe or heavy service applications may require the recommended interval to be reduced. For more information, contact the Mortor OilTec™ Customer Call Center at 866-668-7221.

## **OPTIONAL PARTS SECTION**

**The following pages contain parts information for accessories that can be added to your Demco Drop Deck Trailer.**

**5D000359 - TOOLBOX BRACKET ASSEMBLY, 36" BOX  
(FOR CLOSED SUSPENSION MODELS)**

BOM ID	Part Number	Qty	Description
1	1AF009F000C	16	3/8 SAE FLAT WASHER
2	1AF009J0000	4	5/8 FLAT WASHER
3	1AFC12FAAD5	8	3/8" x 1-1/4" HEX BOLT GRADE 5
4	1AFC12JAAH5	4	5/8"-11 x 1-1/2" HEX BOLT GR. 5
5	1AFC18F0000	8	3/8"-16 HEX NUT NYLOK
6	1AFC18J0000	4	5/8-11 GR.5 NYLOCK NUT
7	5D000355	1	DD UNI TOOLBOX BRACKET, LEFT SIDE ASSY.
8	5D000356	1	DD UNI TOOLBOX BRACKET, RIGHT SIDE ASSY.
9	5D000357	1	DD UNI TOOLBOX BRACKET, CROSS BRACE, 36" BOX
*10	1AU2DBOX136	1	18 x 18 x 36 2-DOOR TOOLBOX (DRIVER SIDE)
*10	1AU2DBOX536	1	18 x 18 x 36 2-DOOR TOOLBOX (PASSENGER SIDE)

**\*The Toolbox is ordered separately from the Bracket Assembly and dependent on which side it is mounted on the trailer.**

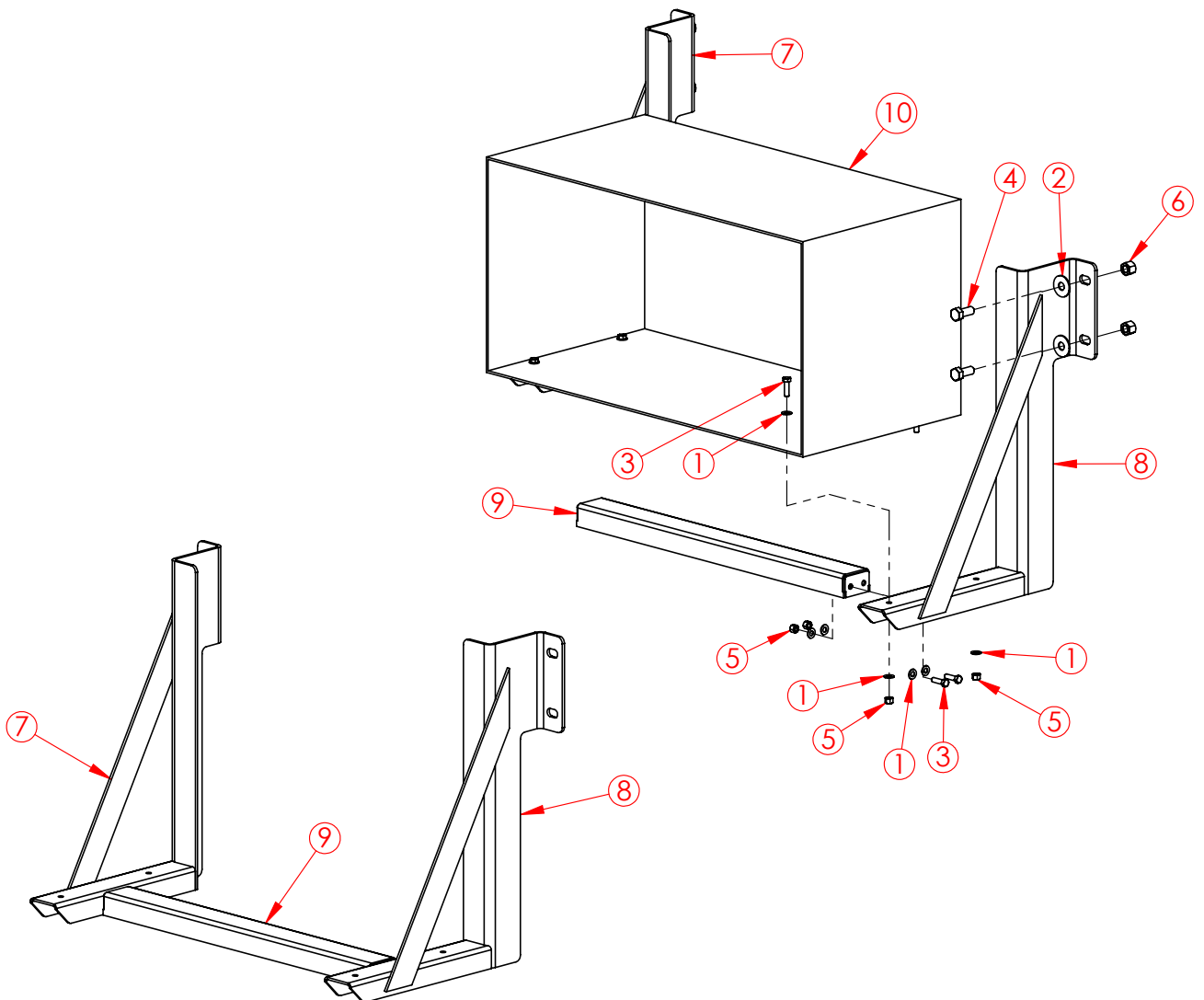

**5D000360 - TOOLBOX BRACKET ASSEMBLY, 48" BOX  
(FOR SPREAD SUSPENSION MODELS)**

BOM ID	Part Number	Qty	Description
1	1AF009F000C	16	3/8 SAE FLAT WASHER
2	1AF009J0000	4	5/8 FLAT WASHER
3	1AFC12FAAD5	8	3/8" x 1-1/4" HEX BOLT GRADE 5
4	1AFC12JAAH5	4	5/8"-11 x 1-1/2" HEX BOLT GR. 5
5	1AFC18F0000	8	3/8"-16 HEX NUT NYLOK
6	1AFC18J0000	4	5/8-11 GR.5 NYLOCK NUT
7	5D000355	1	DD UNI TOOLBOX BRACKET, LEFT SIDE ASSY.
8	5D000356	1	DD UNI TOOLBOX BRACKET, RIGHT SIDE ASSY.
9	5D000358	1	DD UNI TOOLBOX BRACKET, CROSS BRACE, 48" BOX
*10	1AU2DBOX048	1	18 x 24 x 48 2-DOOR TOOLBOX (DRIVER SIDE)
*10	1AU2DBOX548	1	18 x 24 x 48 2-DOOR TOOLBOX (PASSENGER SIDE)

**\*The Toolbox is ordered separately from the Bracket Assembly and dependent on which side it is mounted on the trailer.**

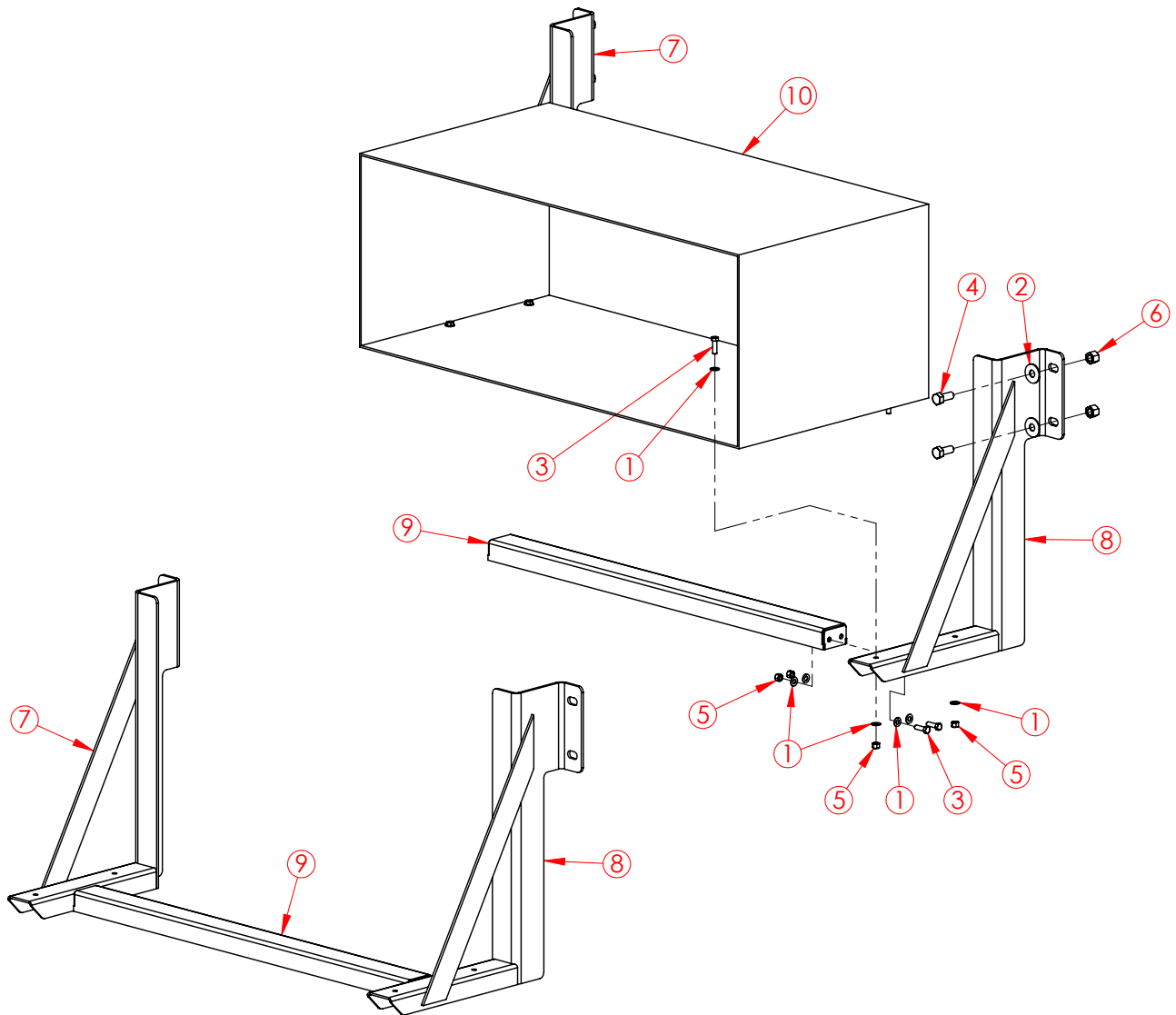

**DEMCO LOGO MUDFLAP OPTION**

Item No	Description	Closed Suspension - Straight (Qty)	Spread Suspension - Straight (Qty)	Closed Suspension w/Beaver Tail (Qty)	Spread Suspension w/Beaver Tail (Qty)
1AFC08E0000	5/16-18 FLANGE NUT	8	16	8	16
1AFC37EAD5	5/16-18 X 1-1/4 FLANGE BOLT	8	16	8	16
1AFV09N0000	3/8 ID X 5/8 OD NYLON WASHER	8	16	8	16
1AU00000804	24" X 30" LOGO, ANTI-SAIL MUDFLAP	-	2	2	4
1AU00000803	24" X 24" LOGO, ANTI-SAIL MUDFLAP	2	2	-	-

**5W000702 - STROBE LIGHT KIT & HARNESS OPTION**

BOM ID	Item No	Qty	Description
1	1AEL040700R	2	4" ROUND GROMMET
2	1AEL044211Y	2	4" ROUND YELLOW LED STROBE LIGHT
3	1AES0096843	1	SPST ON-OFF SWITCH
4	1AE0022523	4	3/16" X 1-1/4" HEAT SHRINK TUBE, 2:1 RATION (100/BAG)
5	1AEC0031920	1	.180" MALE BULLET CONNECTOR BLUE, 16-14GA, HEAT SHRINK
6	1AEC0031921	1	.180" FEMALE BULLET CONNECTOR BLUE, 16-14GA, HEAT SHRINK
7	1AEC0094706	2	PL-3 TO SS ADAPTER
8	1AEW00WD162	14.5'	BRAKE CABLE, 16 GA, 19/29 STRANDING, BLACK & WHITE

**5D000045 - FRONT HEADACHE RACK ASSEMBLY**

BOM ID	Qty	Item No	Description
1	8	1AFC05J0000	5/8" CENTER LOCK NUT
2	6	1AFC12JAAH5	5/8"-11 X 1-1/2" HEX BOLT GR 5
3	2	1AFC12JEAH5	5/8"-11 X 5-1/2" HEX BOLT GR 5
4	1	3D000144	HEADACHE RACK, MAIN SHEET
5	2	3D000145	HEADACHE RACK, VERTICAL BRACE
6	4	3D000146	HEADACHE RACK, TOP & BOTTOM BRACE
7	4	3D000147	HEADACHE RACK, STAKE TUBE
8	2	3D000148	HEADACHE RACK, FRONT BOLT PLATE
9	4	3D000152	TUBE CAP FOR 2 X 3 X 11 GA
10	4	3D000153	TUBE CAP FOR 1.5 X 3 X 7 GA
11	4	3D000154	HEADACHE RACK, TUBE STOP
12	4	3D000155	HEADACHE RACK, SQUARE WASHER
13	1	5D000046	HEADACHE RACK, KICKER ASSEMBLY
14	1	5D000046	HEADACHE RACK, KICKER ASSEMBLY

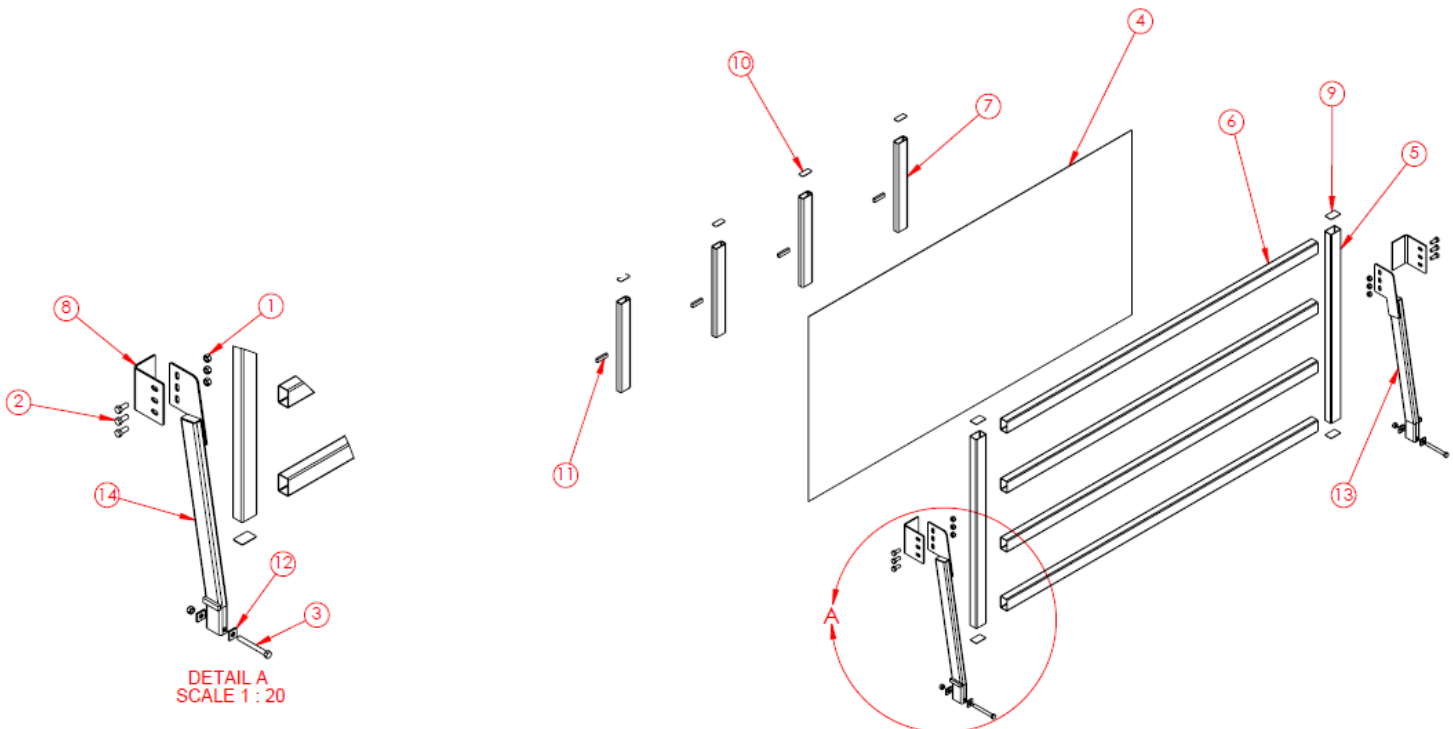

**TAIL HD RAMPS, SPRING ASSIST**

BOM ID	Part Number	Qty	Description
1	5D000286	1	DD HD RAMP, SPRING ASSIST, PASSENGER RAMP ASSEMBLY
2	5D000285	1	DD HD RAMP, SPRING ASSIST, DRIVER RAMP ASSEMBLY
3	5D000283	2	DD RAMP PIVOT ASSEMBLY, HD RAMP, COMPLETE w/ SPRINGS
4	5D000281	4	DD RAMP SPRING BUMP STOP, BUMPER
5	5D000279	1	DD RAMP SHAFT ASSEMBLY, BIG, SPRINGS
6	5D000032	2	RAMP SHAFT ASSY, SMALL - 3 RAMP

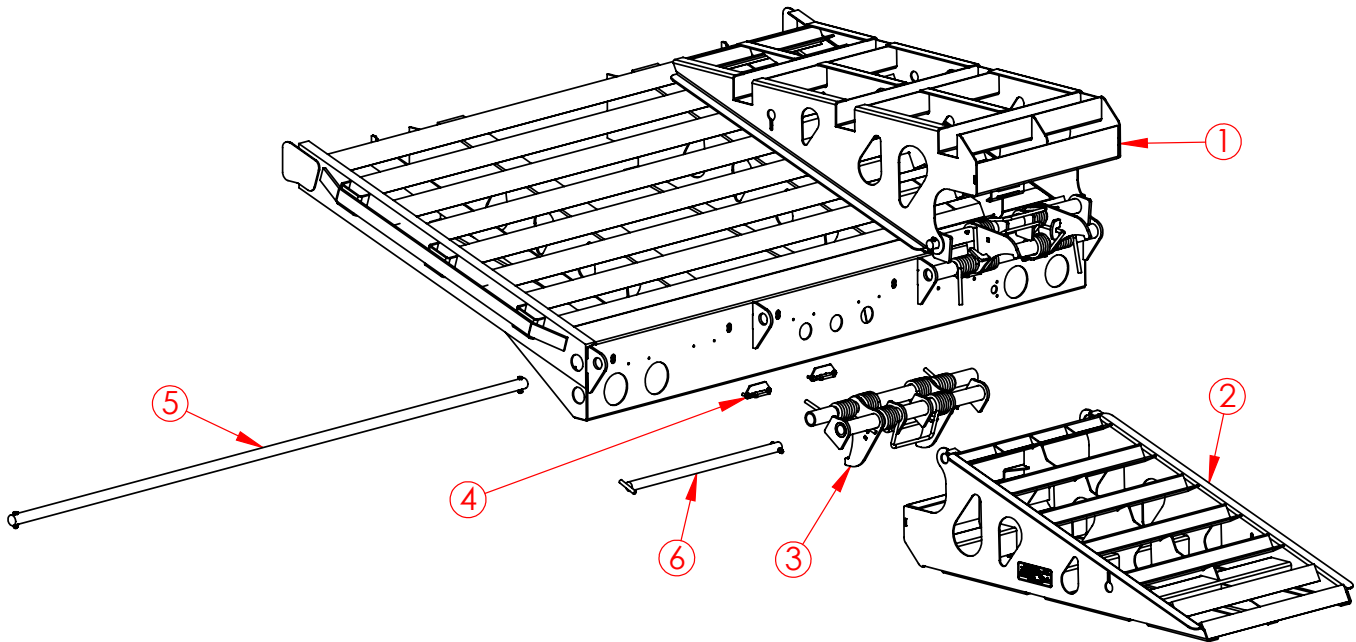

**5D000284 - DD RAMP, SPRING ASSIST, MIDDLE RAMP COMPLETE ASSEMBLY**

BOM ID	Part Number	Qty	Description
1	5D000032	1	RAMP SHAFT ASSY, SMALL - 3 RAMP
2	5D000283	1	DD RAMP PIVOT ASSEMBLY, HD RAMP, COMPLETE w/ SPRINGS
3	5D000287	1	DD HD RAMP, SPRING ASSIST, MIDDLE RAMP ASSEMBLY
4	5D000281	2	DD RAMP SPRING BUMP STOP, BUMPER

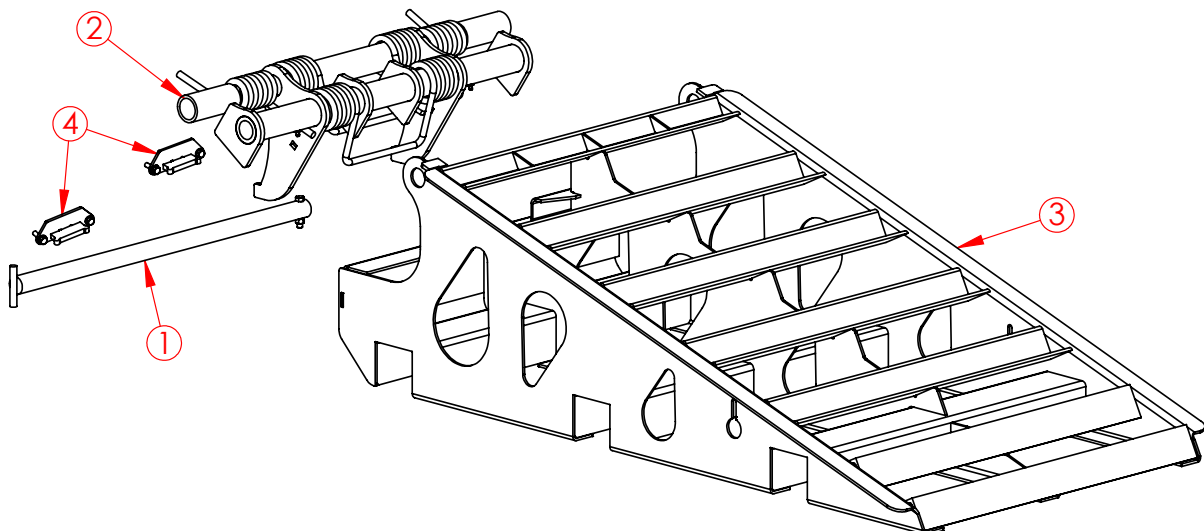

**5D000419 - TOP DECK RAMP ASSEMBLY**

BOM ID	Qty	Item No	Description
1	2	1AFBP3080	NUT, HEX JAM, 5/8"-11 GR 2, ZINC PLATED
2	1	1AFC67FCAE0	5/8"-11 X 2 THREAD TWIST-LK L-HND RETRACT SPRING PLUNGE, 1" PIN EXT
3	1	3D000787	TOP DECK RAMP, STRINGER, LEFT
4	1	3D000788	TOP DECK RAMP, STRINGER, RIGHT
5	1	3D000789	TOP DECK RAMP, BOTTOM PLATE
6	1	3D000790	TOP DECK RAMP, TOP HOOK, LOWER
7	1	3D000791	TOP DECK RAMP, TOP HOOK, UPPER
8	11	3D000792	TOP DECK RAMP, TREAD BAR
9	1	3D000793	TOP DECK RAMP, RETAINER PIN PLATE

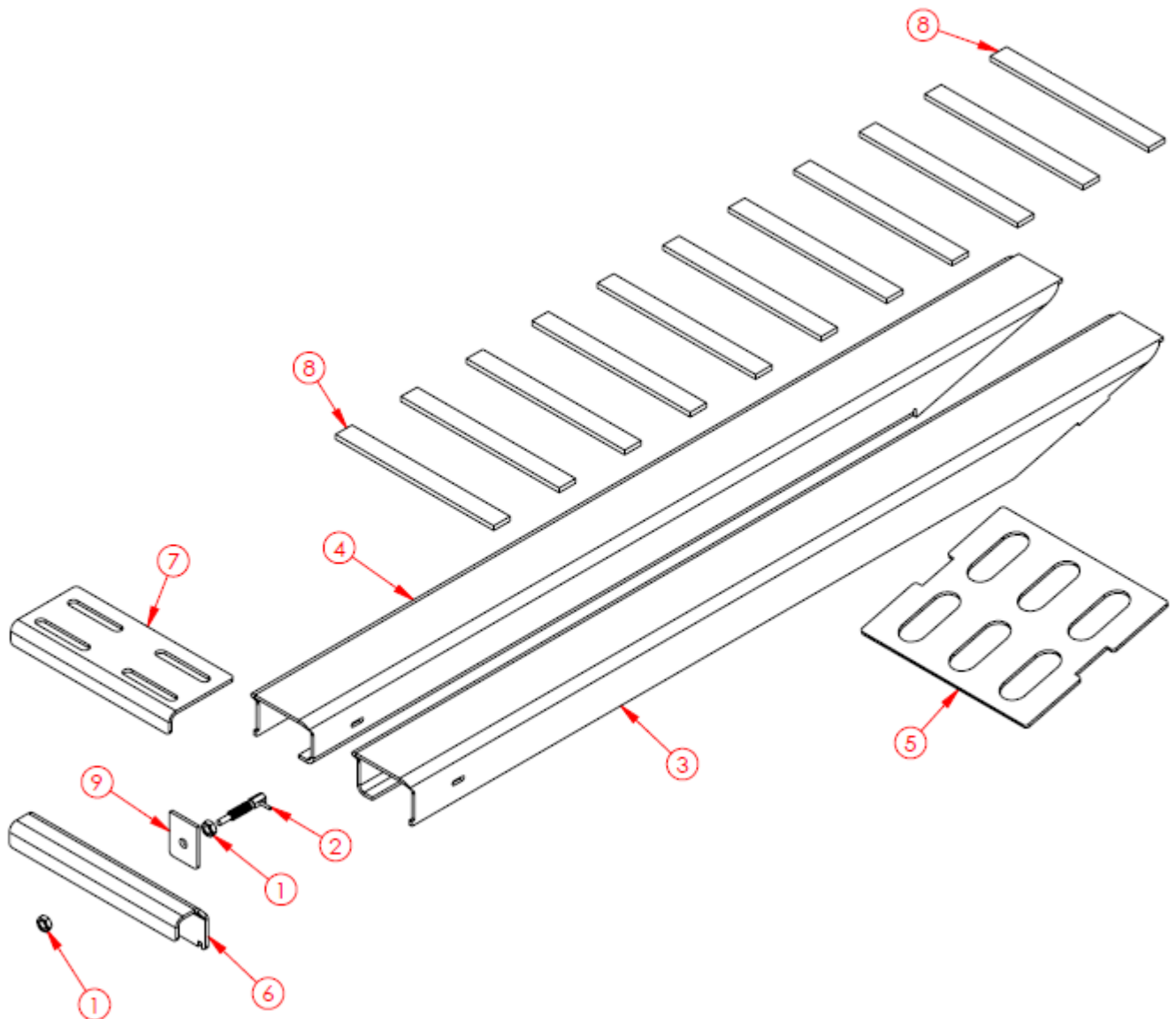

5D000421 - TOP DECK RAMP BULKHEAD CATCH COMPLETE ASSEMBLY

BOM ID	Qty	Item No	Description
1	9	1AF009H0000	1/2" FLAT WASHER, ZINC
2	9	1AFC12HAAH0	1/2"-13 X 1-1/2" HEX BOLT GR 5
3	9	1AFC18H0000	1/2"-13 NYLON LOCKING NUT GR 2, ZINC
4	1	3D000797	TOP DECK RAMP, CATCH BACKER PLATE
5	1	5D000420	TOP DECK RAMP, BULKHEAD CATCH ASSEMBLY

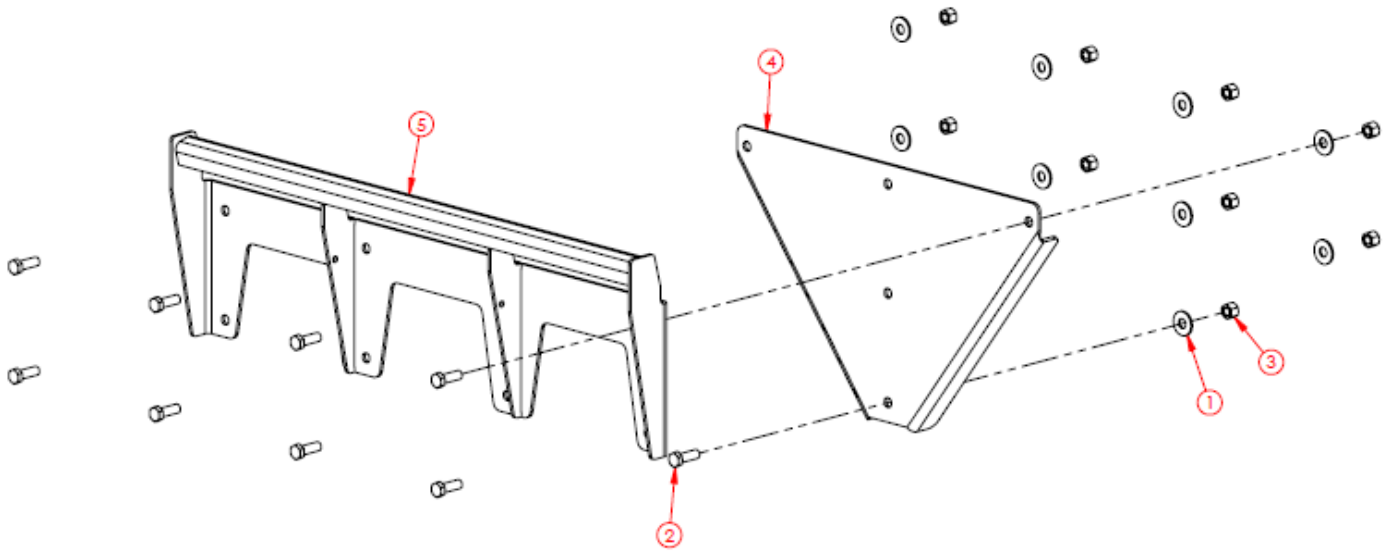

DD TOP DECK RAMP BULKHEAD CATCH - FIELD INSTALLATION

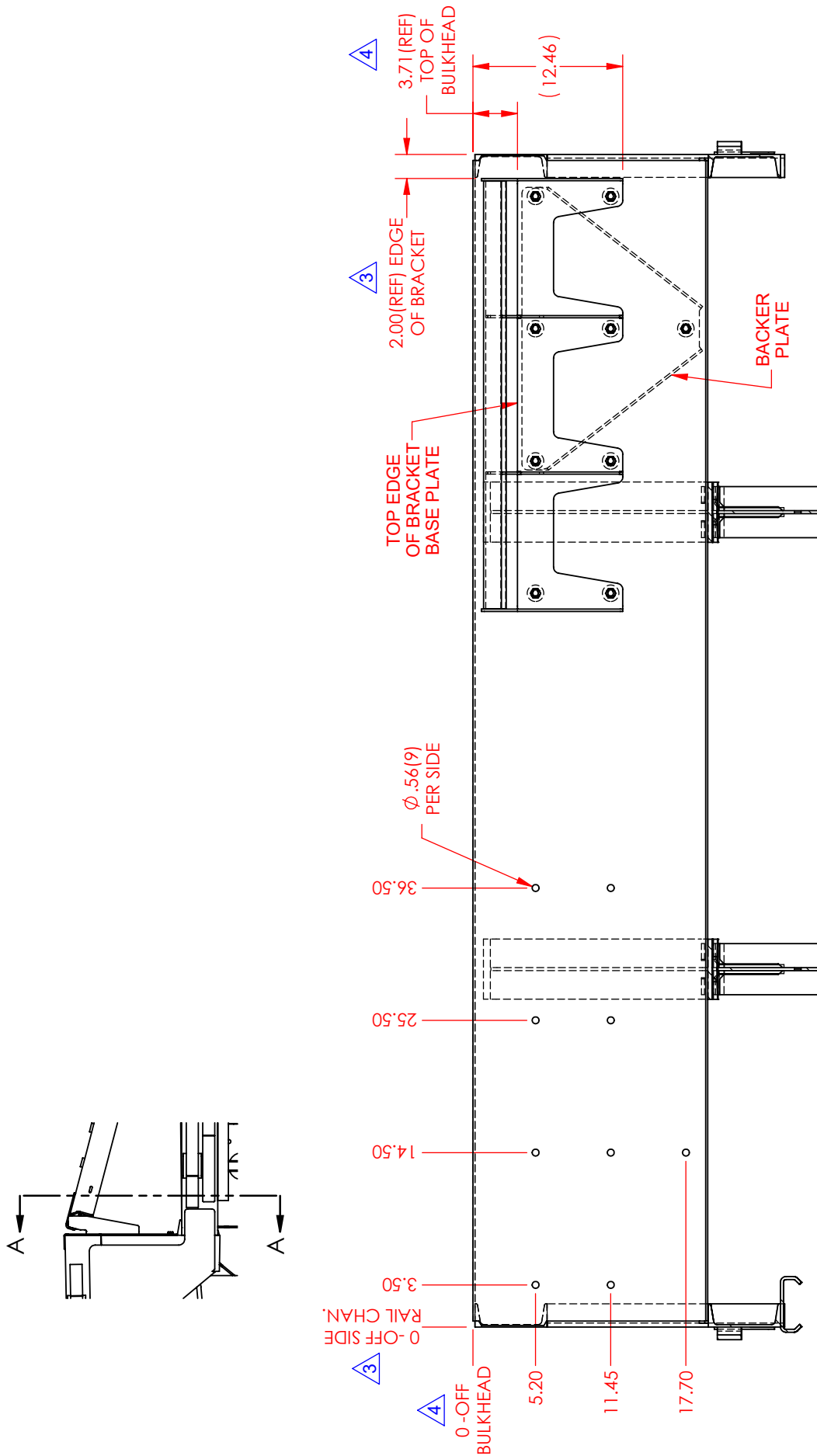

NOTES:

1. TORQUE ALL 1/2" FASTENERS TO 75 FT/LBS.
2. WASHERS & NUTS INSTALLED ON BACK SIDE OF BULKHEAD OR BACKER PLATE.
3. HORIZONTAL DIMS PULLED FROM EDGE OF SIDE RAIL CHANNEL.
4. VERTICAL DIMS PULLED FROM TOP OF BULKHEAD.

5D000424 - TOP DECK RAMP STORAGE COMPLETE ASSEMBLY

BOM ID	Qty	Item No	Description
1	16	1AF009F0000	3/8" FLAT WASHER, PLATED
2	2	1AF026EBAH0	5/16" X 2-1/1" LINCH PIN
3	16	1AFC04FAAD0	3/8"-16 X 1-1/4" SH NECK CARR GR 5
4	16	1AFC18F0000	3/8"-16 HEX NUT NYLOCK
5	4	3D000802	TOP DECK RAMP, STORAGE HANGER CHANNEL
6	8	3D000803	TOP DECK RAMP, STORAGE HANGER CLAMP
7	2	3D000804	TOP DECK RAMP, STORAGE RAMP KEEPER
8	2	5D000422	TOP DECK RAMP, STORAGE CARRIER ASSEMBLY
9	2	5D000423	TOP DECK RAMP, STORAGE HANGER ASSEMBLY

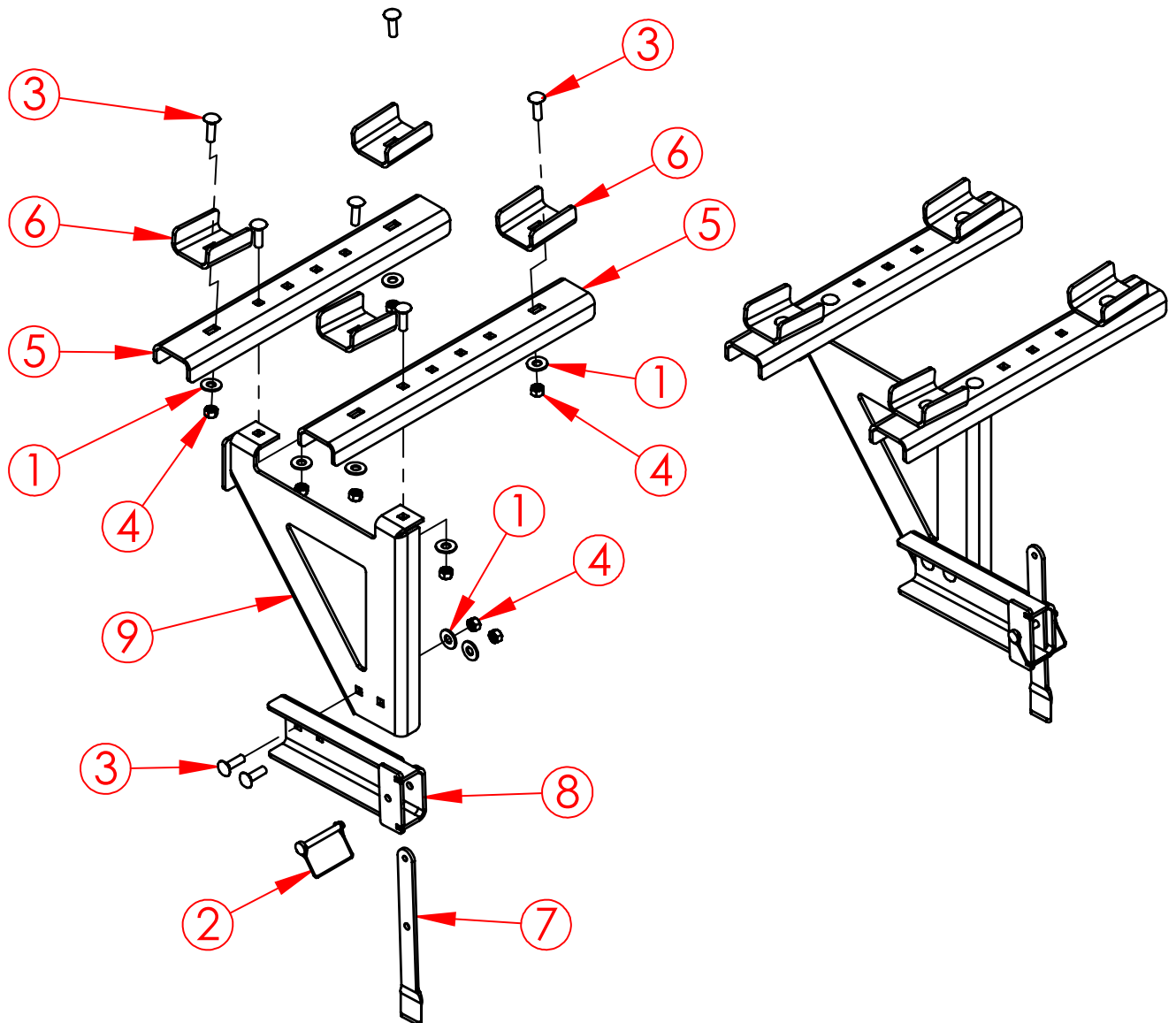

**DD TOP DECK RAMP STORAGE BRACKETS - FIELD INSTALLATION**

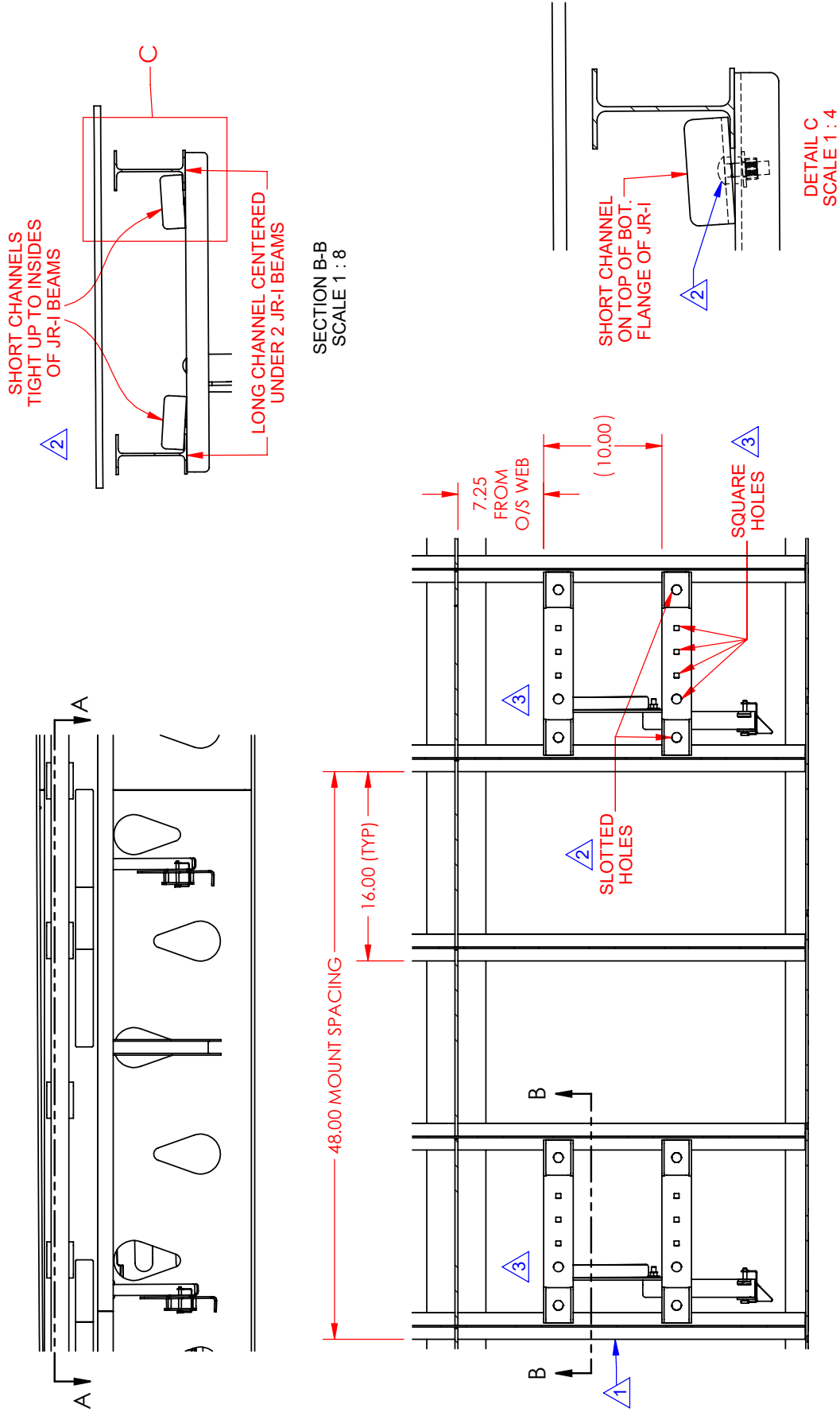

- NOTES:**
- IF TRAILER HAS TOOLBOX, START MOUNTING AT 5TH JR-I BEAM FROM BULKHEAD.
  - SHORT CHANNELS ALWAYS MOUNT TO SLOTTED HOLES.
  - SQUARE HOLE USAGE MUST BE CONSISTENT TO EACH HANGER.
  - TORQUE ALL 3/8" FASTENERS TO 30 FT/LBS.

**5D000400 - WELD-ON WINCH ASSEMBLY, DRIVER SIDE, TAIL ONLY**

BOM ID	Qty	Item No	Description
1	1	1AU00170136	WINCH - NOTCHED SLIDER
2	1	3D000291	WELD-ON WINCH WEDGE

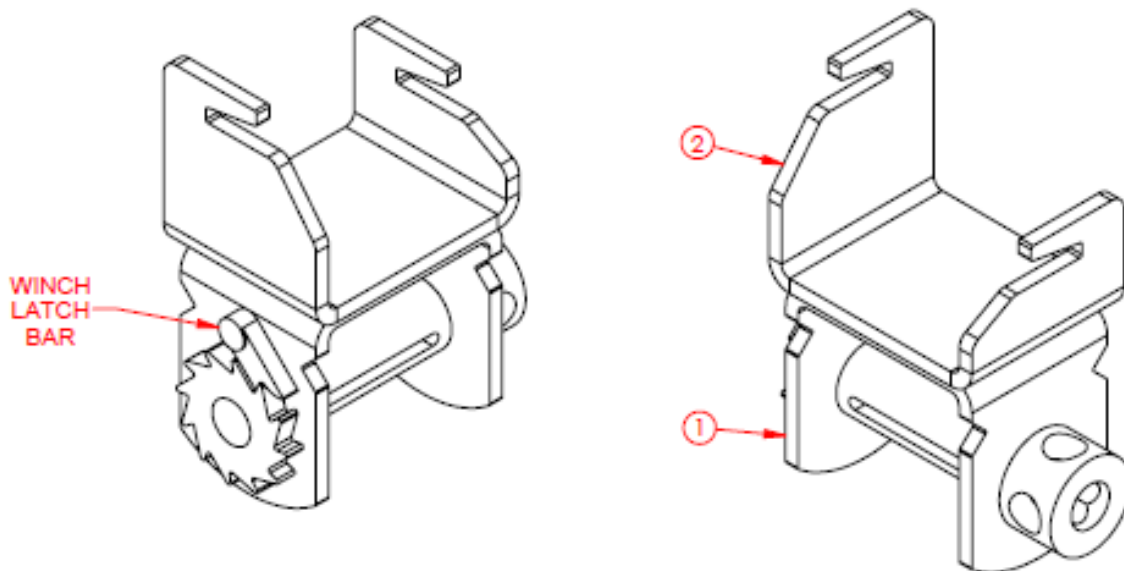

**2D000074 - SLIDING WINCHES  
FOR ALL MODELS EXCEPT STEEL FLOORS**

BOM ID	Qty	Item No	Description
1	1	1AU00170136	WINCH - NOTCHED SLIDER



**DEMCO**

4010 320th St., Boyden, IA. 51234

Phone: (712) 725-2311

Fax: (712) 725-2380

Toll Free: 1-800-54DEMCO (1-800-543-3626)

**Demco warranty policies, operator manuals, and product registration  
can be found online:**

**[www.demco-products.com](http://www.demco-products.com)**