



Doing Our Best to Provide You the Best

HJ26401, Rev 0
7/21

5TH WHEEL SIDE RAIL ASSEMBLIES

6401 AS Ram Factory Prep

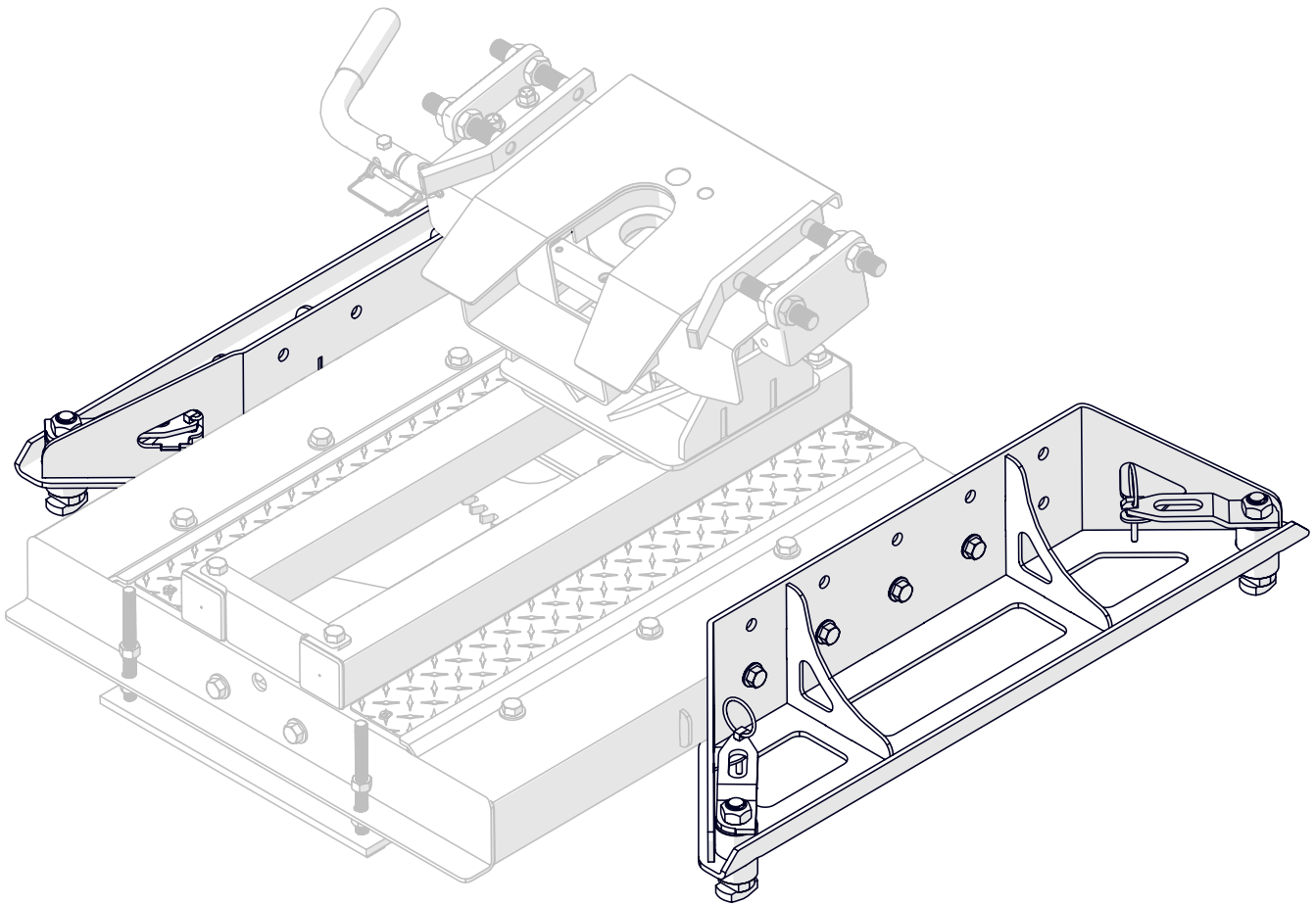

OPERATOR MANUAL

WARRANTY POLICY, OPERATOR MANUALS, PARTS MANUALS & REGISTRATION

Go online to www.demco-products.com to review Demco warranty policies, operator manuals and register your Demco product.

Torque Specifications

BOLT TORQUE DATA FOR STANDARD NUTS, BOLTS, AND CAP-SCREWS.

Tighten all bolts to torques specified in chart unless otherwise noted. Check tightness of bolts periodically, using bolt chart as guide. Replace hardware with same grade bolt.

NOTE: Unless otherwise specified, high-strength Grade 5 hex bolts are used throughout assembly of equipment.

Torque figures indicated are valid for non-greased or non-oiled threads and heads unless otherwise specified. Therefore, do not grease or oil bolts or capscrews unless otherwise specified in this manual. When using locking elements, increase torque values by 5%.

* GRADE or CLASS value for bolts and capscrews are identified by their head markings.

Bolt Torque for Standard bolts *

"A"	GRADE 2		GRADE 5		GRADE 8	
	lb-ft	(N.m)	lb-ft	(N.m)	lb-ft	(N.m)
1/4"	6	(8)	9	(12)	12	(16)
5/16"	10	(13)	18	(25)	25	(35)
3/8"	20	(27)	30	(40)	45	(60)
7/16"	30	(40)	50	(70)	80	(110)
1/2"	45	(60)	75	(100)	115	(155)
9/16"	70	(95)	115	(155)	165	(220)
5/8"	95	(130)	150	(200)	225	(300)
3/4"	165	(225)	290	(390)	400	(540)
7/8"	170	(230)	420	(570)	650	(880)
1"	225	(300)	630	(850)	970	(1310)

Bolt Torque for Metric bolts *

"A"	CLASS 8.8		CLASS 9.8		CLASS 10.9	
	lb-ft	(N.m)	lb-ft	(N.m)	lb-ft	(N.m)
6	9	(13)	10	(14)	13	(17)
7	15	(21)	18	(24)	21	(29)
8	23	(31)	25	(34)	31	(42)
10	45	(61)	50	(68)	61	(83)
12	78	(106)	88	(118)	106	(144)
14	125	(169)	140	(189)	170	(230)
16	194	(263)	216	(293)	263	(357)
18	268	(363)	--	--	364	(493)
20	378	(513)	--	--	515	(689)
22	516	(699)	--	--	702	(952)
24	654	(886)	--	--	890	(1206)

1. Prefit the side rails in the pucks of the truck and make sure the handles will lock into place. If handles are too tight or don't lock into place, remove top nut from parts breakdown and take handle out of bushing. There will be a couple of washers between handle and bushing that can be removed to adjust the tightness of the handles in the trucks pucks. Reinstall handles and check for fit.
2. Loosely bolt the main Autoslide assembly to the side rails using the 1/2" x 1 1/2" bolts, flat washers, and lock nuts provided in the side rail bolt package at the predetermined height using the bolt pattern guide in below.
3. Tighten all bolts.
4. Unlock locking pins and insert the hitch assembly into the base rails and test for fit.
5. Proceed to base rail install procedure as provided in the base rail installation kit.

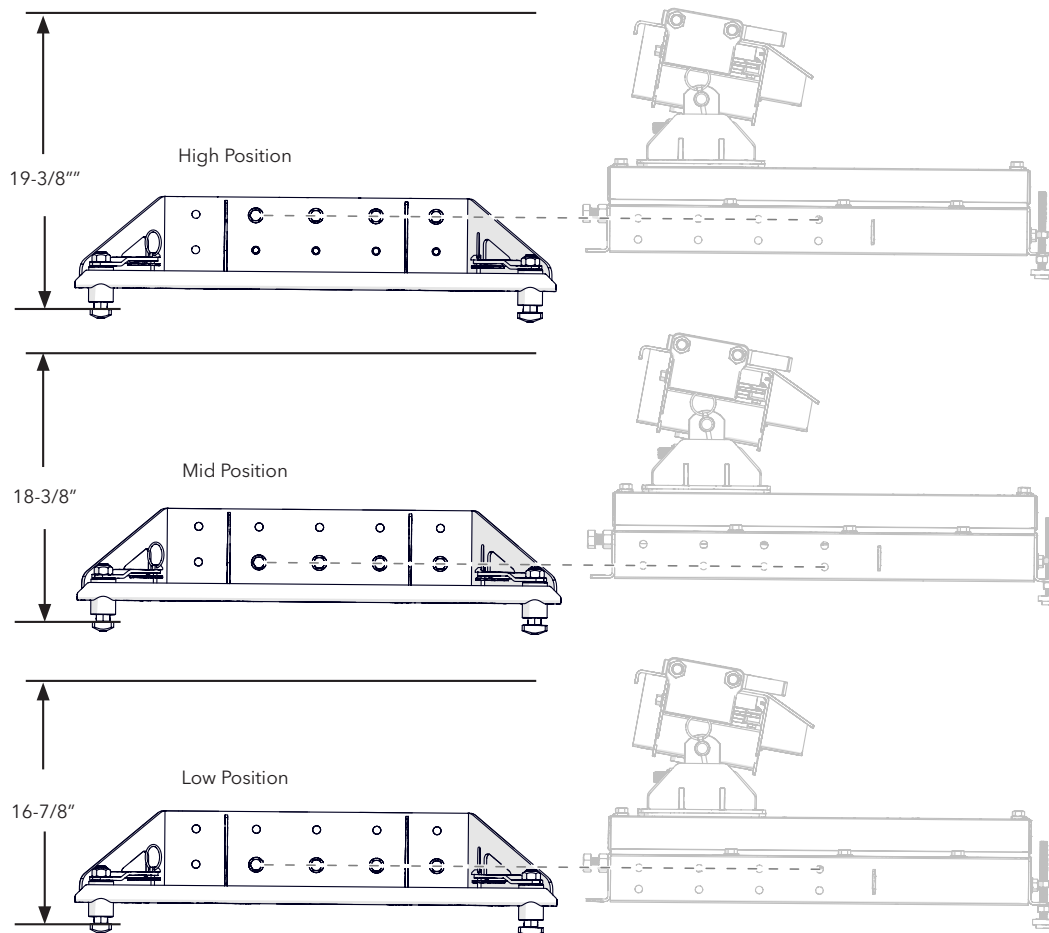

IMPORTANT NOTE: Incorrect mounting of the side plates to the main body will result in the incorrect position of the hitch for towing and will not allow the hitch to travel back to its full ability.

IMPORTANT NOTE: Apply a little grease or lubricant to the part of the pins that insert into the base rails to help maintain smooth operation and rotation of pins and to protect from the elements. Turn the pins occasionally to prevent them from seizing.

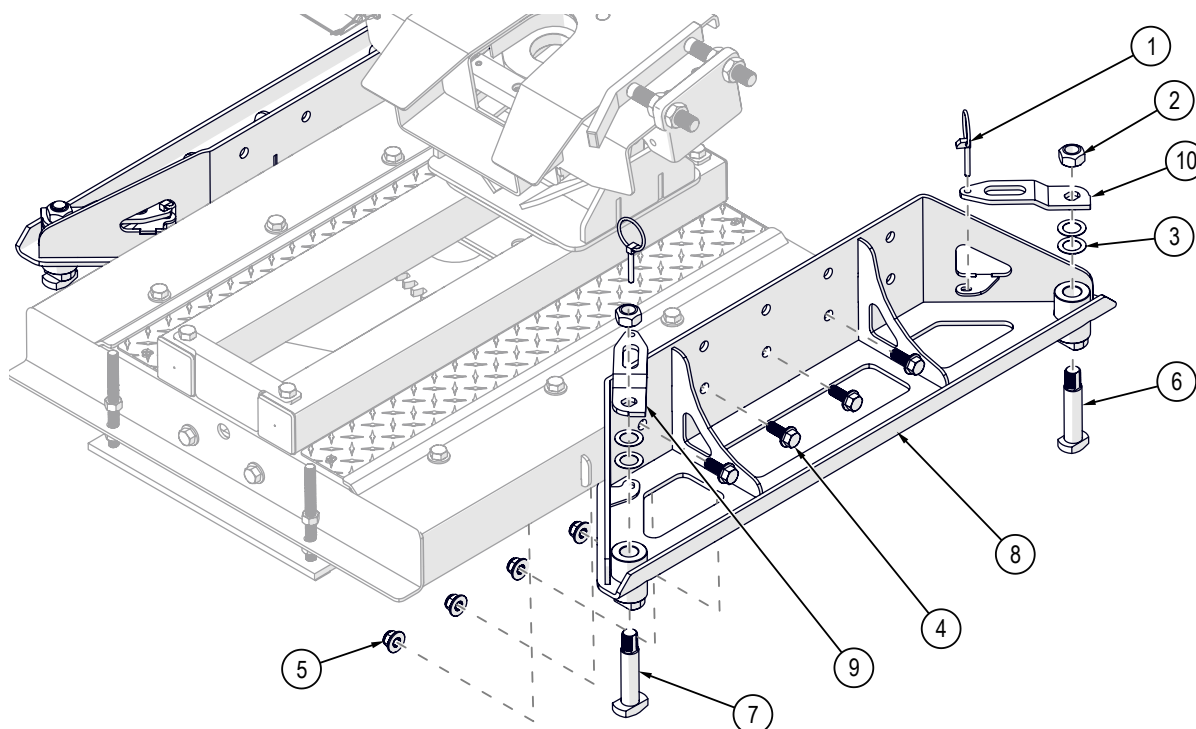
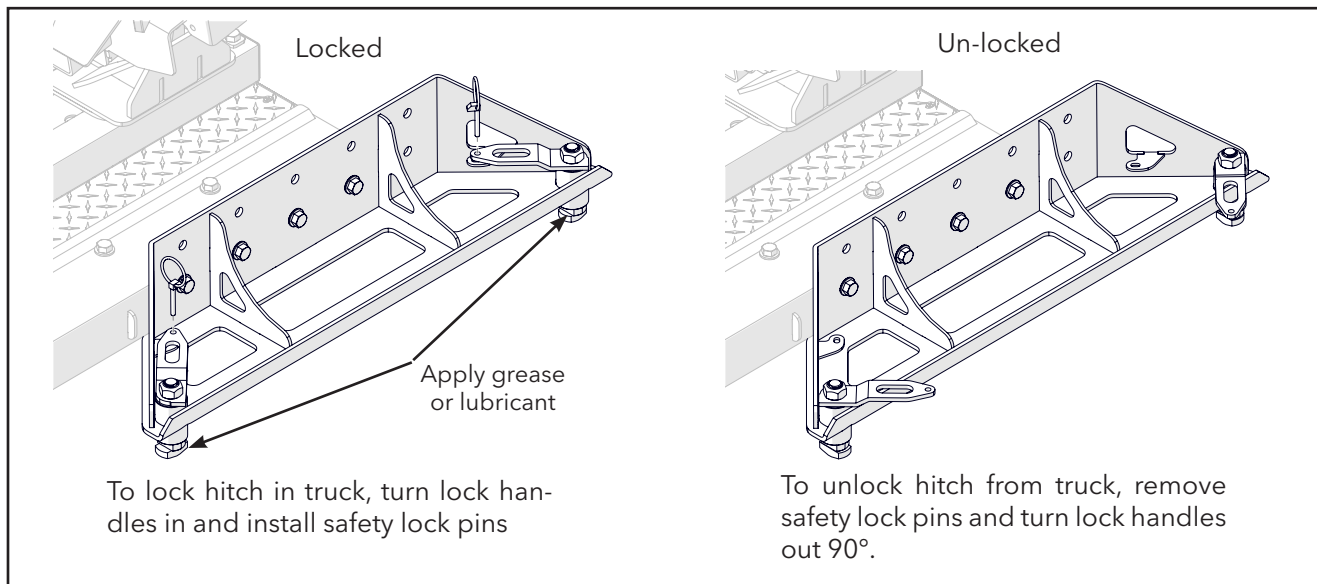

ITEM	PART #	DESCRIPTION	Qty
1	02397	LYNCH PIN	4
2	09726	NUT .75NF LOCK STOVER GR. C	4
3	14423	WASHER SHIM .875 ID X .030 THK	8
4	16589	BOLT .50NC X 1.50 GR5 HEX FLANGE	8
5	16590	NUT, .50NC LOCK, NY. INSERT FLANGE	8
6	17112-95	LOCKING STUD	2
7	17113-91	LOCKING STUD F/RAM	2
8	17375-76	SIDE RAIL AS F/RAM PREP	2
9	17376-95	LATCH HANDLE F/RAM PREP AS, LEFT	2
10	17377-95	LATCH HANDLE F/RAM PREP AS, RT	2

Please order replacement parts by PART NO. and DESCRIPTION

DEMCO

4010 320th St., Boyden, IA. 51234

Phone: (712) 725-2311

Fax: (712) 725-2380

Toll Free: 1-800-54DEMCO (1-800-543-3626)

Demco warranty policies, operator manuals, and product registration can be found online:

www.demco-products.com

