

SIDEQuest[®]

by Demco

7-15
AC20113,rev0

John Deere 8R PS FT4
8245R, 8270R, 8295R,
8320R, 8345R, 8370R

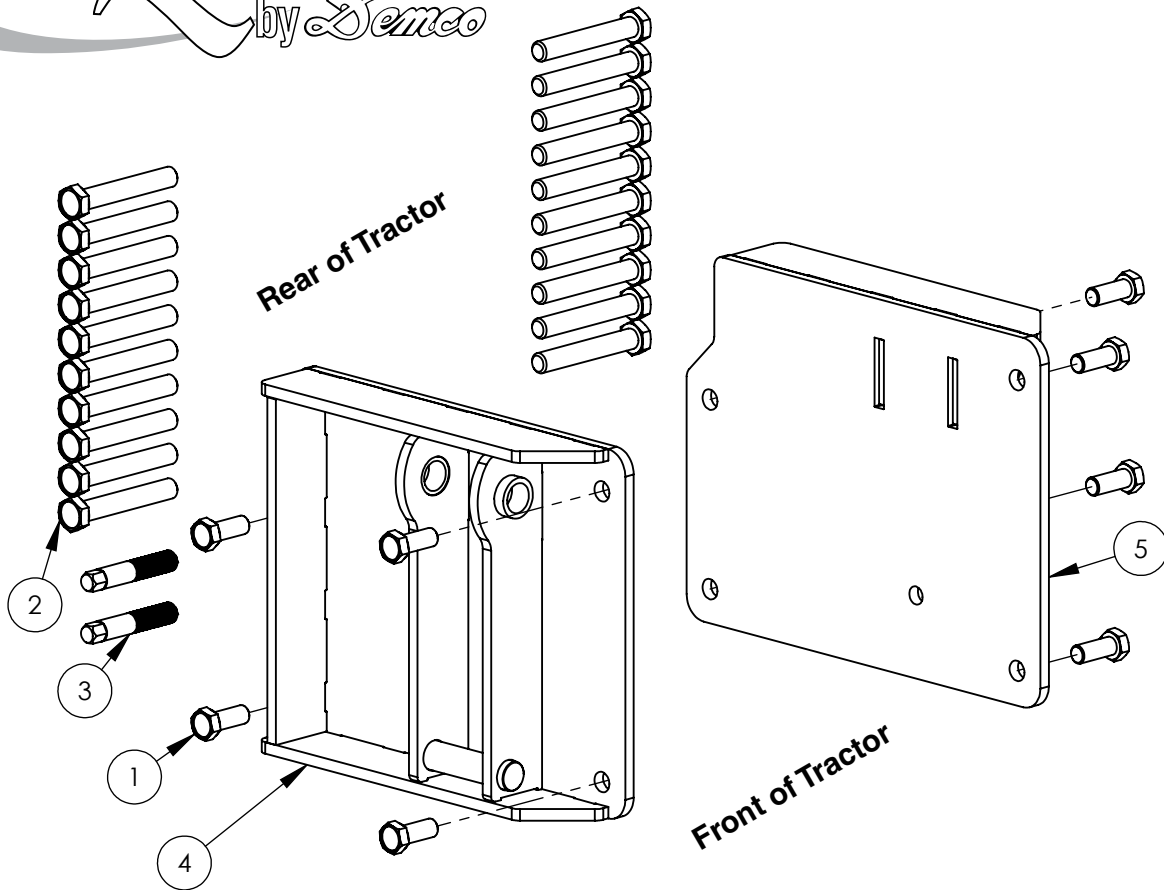

Optional: Kit# 6139 For Fuel/Water Separator

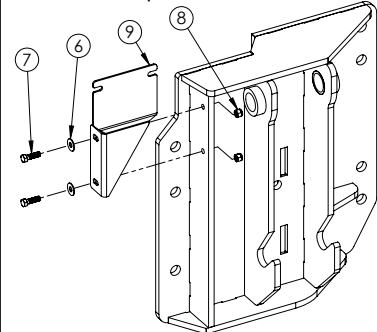

Use 13/32" drill bit and use bracket as drill template. Drill two holes and secure using provided fasteners. Attach filter with existing hardware.

BOLT TORQUE SPECIFICATIONS

Size	Grade	Torque	Size	Grade	Torque
20MM	10.9	515 ft/lbs.	22MM	10.9	702 ft/lbs.

READ complete manual CAREFULLY BEFORE attempting operation.

WARNING

To prevent serious injury or death

On John Deere tractors check hub thickness. If thickness is greater than 2.31" standard bolts will fail. 13586 Hex Bolt 22MM-2.50 x 140 MM GR. 10.9 must be used.

REV 0 AC21005

REPLACEMENT PARTS

ITEM	PART #	DESCRIPTION	QTY.
1.	03840	Bolt, 20MM-2.50 x 50MM Gr10.9	8
2.	13586	Bolt, 22MM-2.50 x 140MM Gr10.9 (Heavy)	20
-	13222	Bolt, 22MM-2.50 x 120MM Gr10.9 (Std)	20
3.	13919-95	Starter Stud	2
4.	15401-76	Right Baseplate For Deere PS FT4	1
5.	15402-76	Left Baseplate For Deere PS FT4	1
6.	00059	Washer, Flat .375	2
7.	00523	Bolt, .375NC X 1.25 Hex Head Gr5	2
8.	02592	Nut, .375NC Nylon Lock	2
9.	15378-76	John Deere Fuel Filter Bracket	1

Please order replacement parts by **PART NO.** and **DESCRIPTION.**

DEMCO • 4010 320th Street • P.O. Box 189 • Boyden, IA 51234

PH: (712) 725-2311 • Toll Free: 1-800-543-3626 • FAX: (712) 725-2380 or 1-800-845-6420

www.demco-products.com