

BOLT TORQUE SPECIFICATIONS		
Size	Grade	Torque
3/8"	5	30 ft/lbs.
1/2"	5	75 ft/lbs.
20MM	10.9	515 ft/lbs.
22MM	10.9	702 ft/lbs.

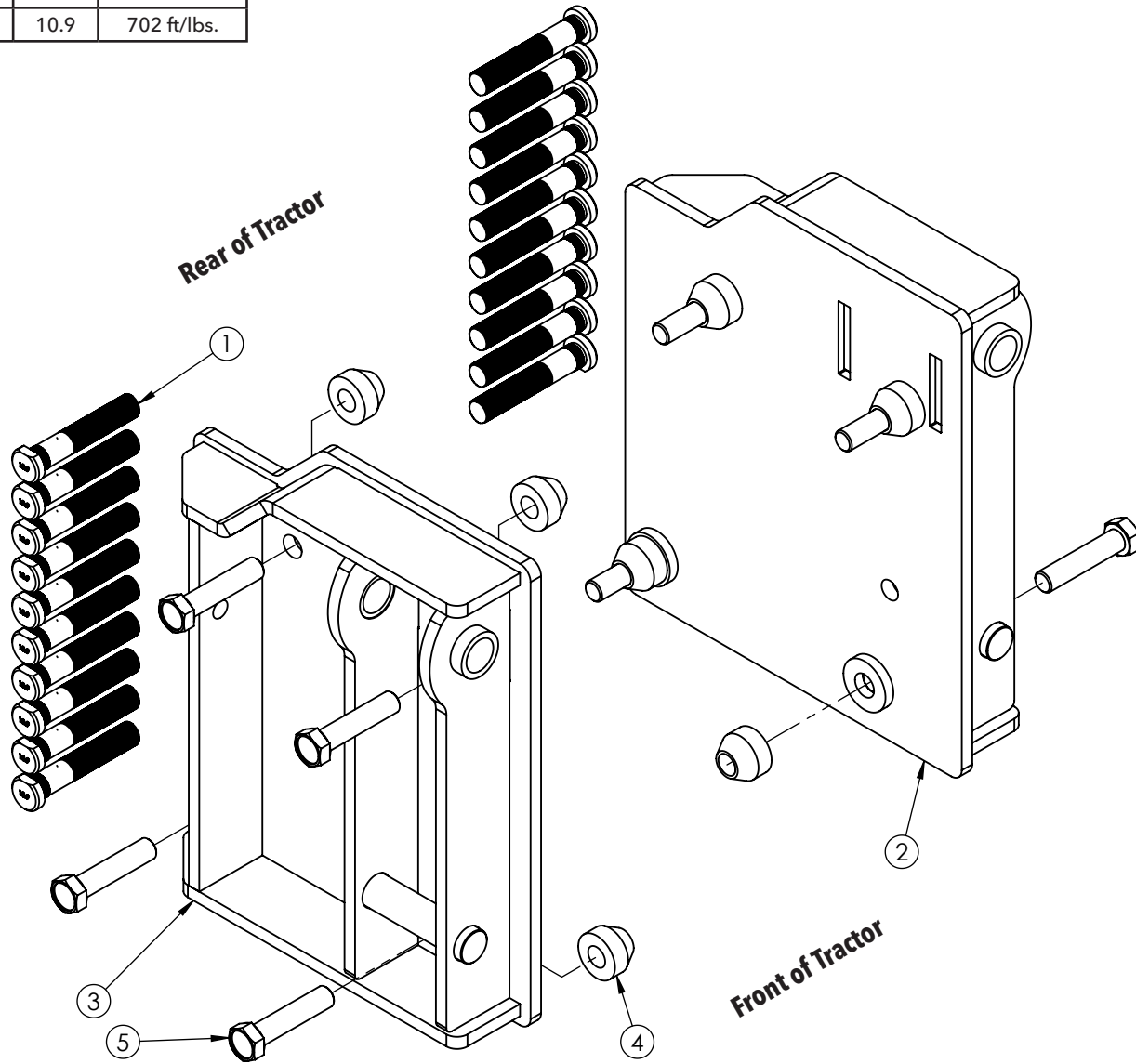

ITEM	PART #	DESCRIPTION	QTY.
1.	14601	Wheel Stud, 22MM-1.50 x 120MM Gr10.9	20
2.	14630-35	Left Baseplate f/ Massey/Challenger	1
3.	14631-35	Right Baseplate f/ Massey/Challenger	1
4.	14638-95	Bushing, Tapered SQ	8
5.	14651	Bolt, 20MM-2.50 x 90MM Gr10.9	8

Please order replacement parts by PART NO. and DESCRIPTION.

Baseplate Install Instructions

1. Remove fenders, fuel filter brackets, and (8) plastic inserts. **(A)**
2. Remove existing wheel studs and replace with 120mm long wheel studs.

When tightening wheel nuts, follow tractor manufacturing instructions.

3. Install baseplate with hardware. Use Tapered Bushings inbetween baseplate and tractor frame. **Shown on front cover.**
4. Install optional fuel filter bracket with hardware.
5. Tighten bolts attaching baseplate to tractor frame.

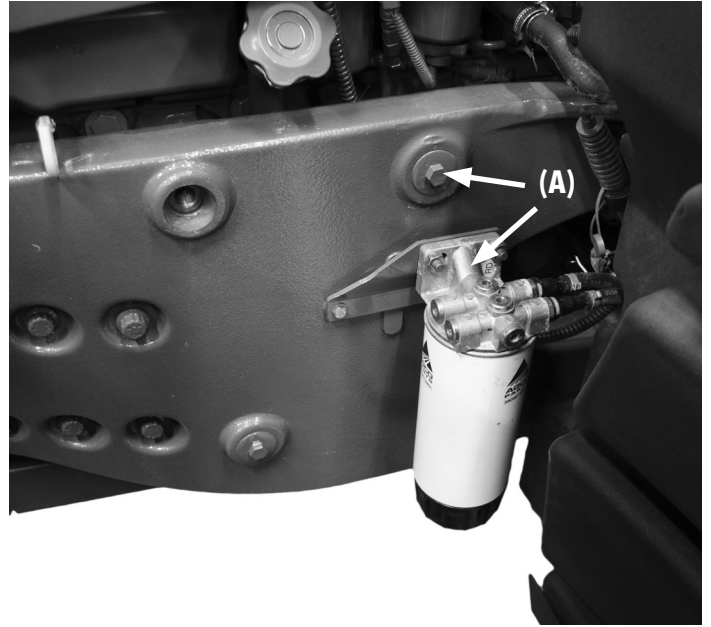

Fuel Filter Bracket Install Instructions

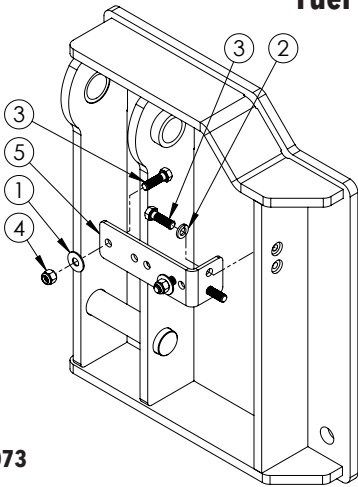

OPTIONAL KIT # 6073
Fuel Filter Bracket

ITEM	PART #	DESCRIPTION	QTY.
1.	00059	Washer, 3/8"	2
2.	00060	Washer, 3/8" Lock	2
3.	00523	Bolt, 3/8" NC x 1.25 Gr5	4
4.	02592	Nut, 3/8" Nylon Insert Lock	2
5.	14637-35	Bracket, Fuel Filter	1

Please order replacement parts by PART NO. and DESCRIPTION.

Extention Bracket Install Instructions

1. Attach Extention Bracket to saddle with hardware.
2. Use existing hardware to attach Hanger Bracket to Extention Bracket. **(refer to AC20037)**

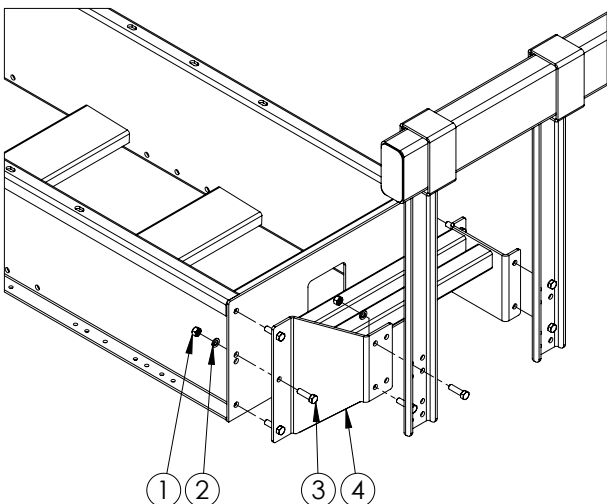

ITEM	PART #	DESCRIPTION	QTY.
1.	00083	Nut, 1/2"	10
2.	00084	Washer, 1/2" Lock	10
3.	00482	Bolt, 1/2" NC x 1.75 Gr5	10
4.	14636-35	Extention Bracket, RH 1000 SQ	1
-	14632-35	Extention Bracket, LH 1000 SQ	1

Please order replacement parts by PART NO. and DESCRIPTION.