

BOLT TORQUE SPECIFICATIONS		
Size	Grade	Torque
3/8"	5	30 ft/lbs.
3/4"	5	290 ft/lbs.
20MM	10.9	515 ft/lbs.
22MM	10.9	702 ft/lbs.

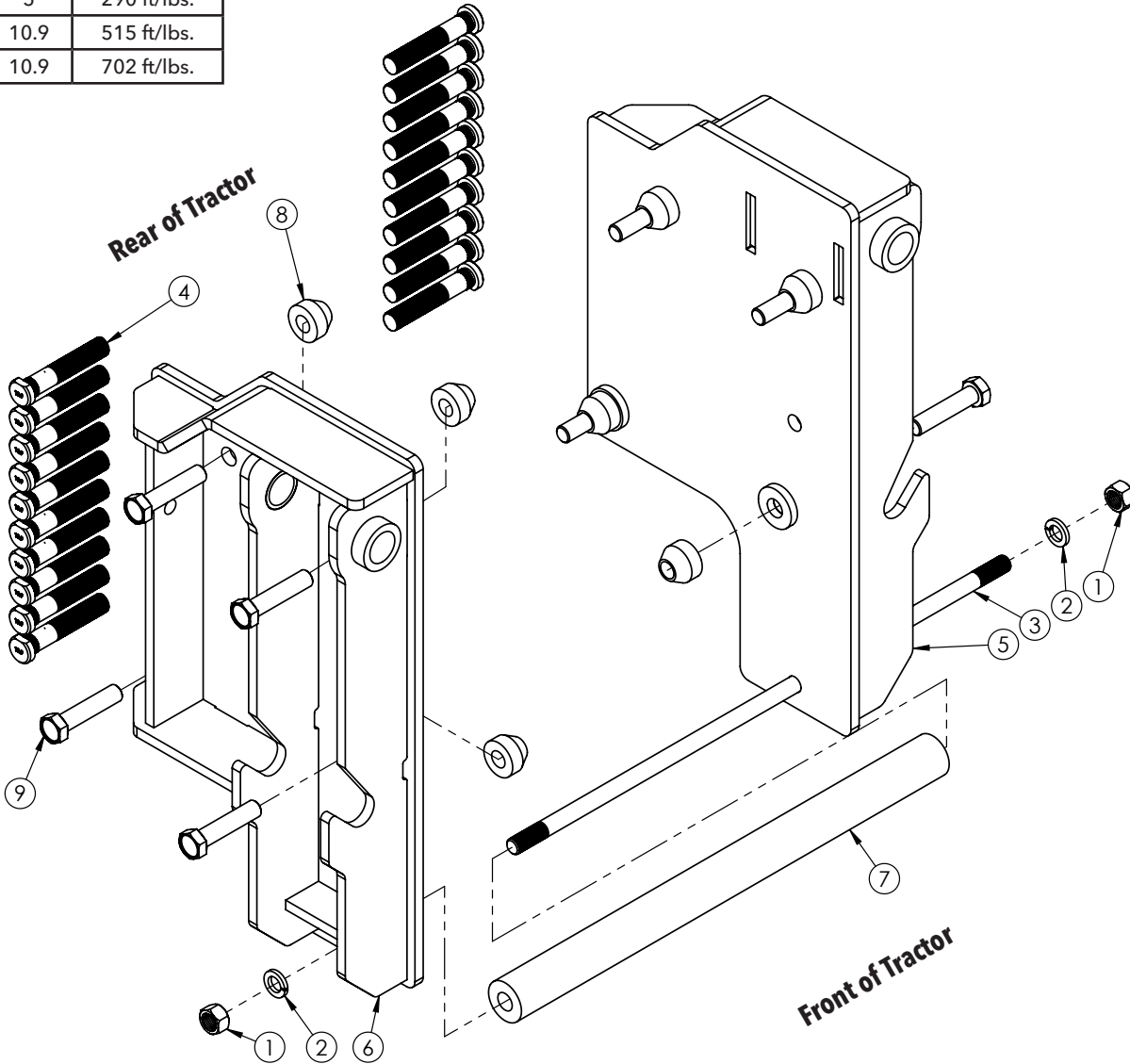

ITEM	PART #	DESCRIPTION	QTY.
1.	00253	Nut, 3/4" Hex	2
2.	00254	Washer, 3/4" Lock	2
3.	14061	Cross Shaft	1
4.	14601	Wheel Stud, 22MM-1.50 x 120MM Gr10.9	20
5.	14633-72	Left Baseplate f/ Massey/Challenger	1
6.	14634-72	Right Baseplate f/ Massey/Challenger	1
7.	14635-72	Spacer, Tube	1
8.	14638-95	Bushing, Tapered SQ	8
9.	14651	Bolt, 20MM-2.50 x 90MM Gr10.9	8

Please order replacement parts by PART NO. and DESCRIPTION.

Baseplate Install Instructions

1. Remove fenders, fuel filter brackets, and (8) plastic inserts. **(A)**
2. Remove existing wheel studs and replace with 120mm long wheel studs.

When tightening wheel nuts, follow tractor manufacturing instructions.

3. Install baseplate with hardware. Use Tapered Bushings in between baseplate and tractor frame. **Shown on front cover.**
4. Install optional fuel filter bracket with hardware.
5. Tighten bolts attaching baseplate to tractor frame.

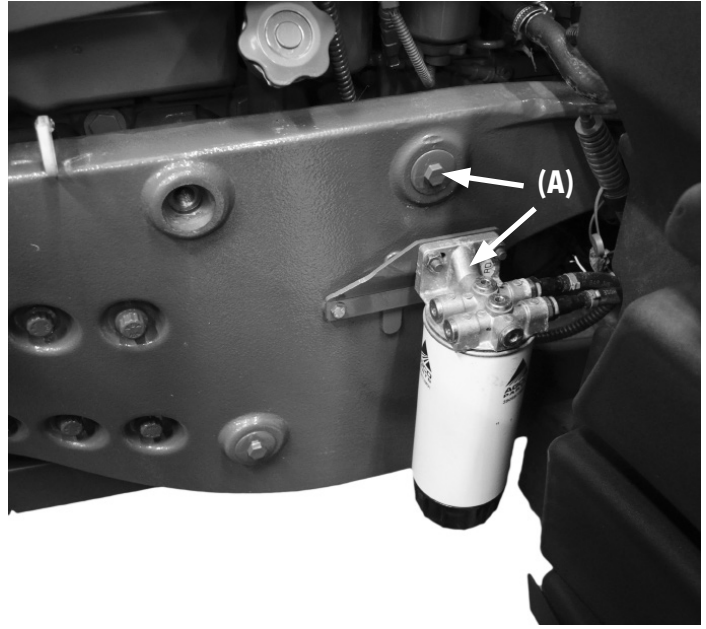

Fuel Filter Bracket Install Instructions

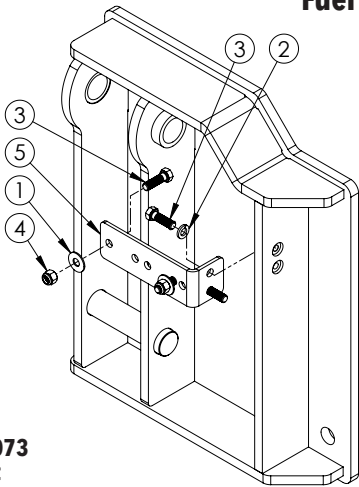

**OPTIONAL KIT # 6073
Fuel Filter Bracket**

ITEM	PART #	DESCRIPTION	QTY.
1.	00059	Washer, 3/8"	2
2.	00060	Washer, 3/8" Lock	2
3.	00523	Bolt, 3/8" NC x 1.25 Gr5	4
4.	02592	Nut, 3/8" Nylon Insert Lock	2
5.	14637-35	Bracket, Fuel Filter	1
Please order replacement parts by PART NO. and DESCRIPTION.			