

# Demco QUICK TACH INLINE MOUNTING BRACKETS

12-11  
AC20085,rev1

**NEW HOLLAND**  
T8.275, T8.300, T8.330,  
T8.360

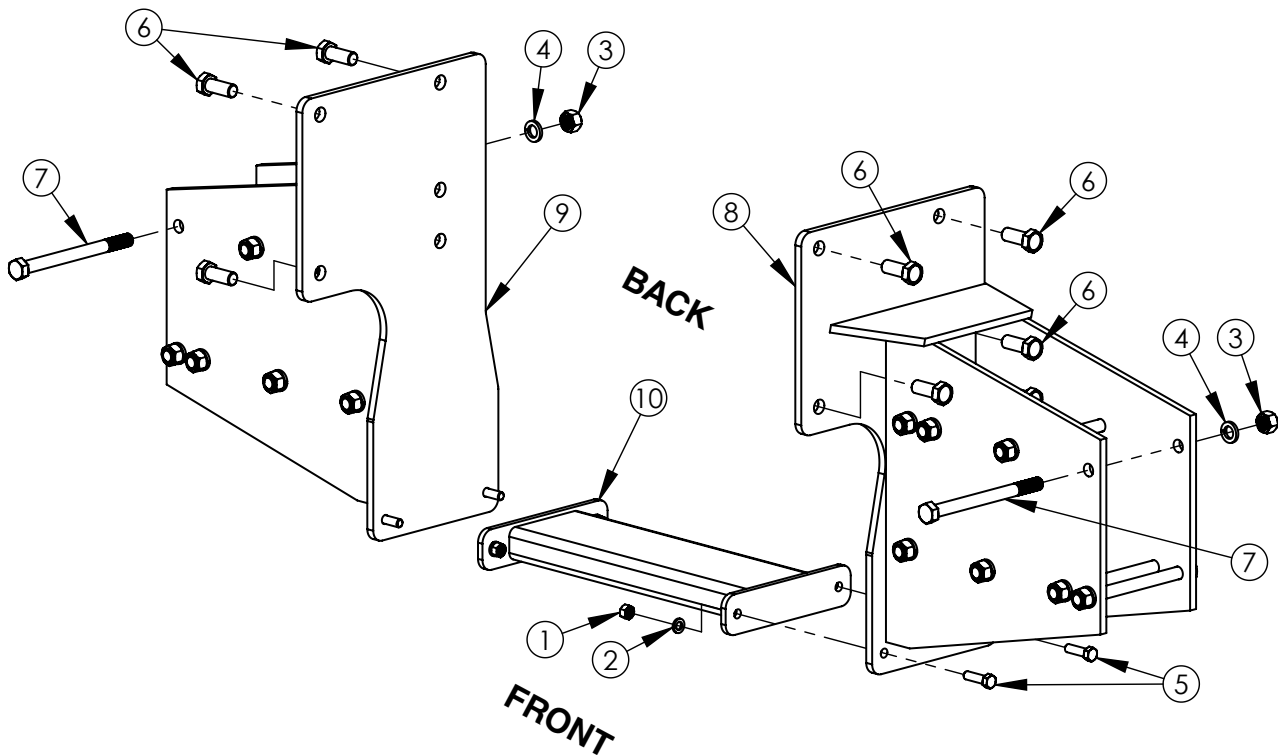

### ASSEMBLY REPLACEMENT PARTS

REF. PART NO.	PART NO.	QTY.	DESCRIPTION
1.	00083	4	1/2" - 13UNC Hex Nut
2.	00084	4	1/2" Lockwasher
3.	00253	16	3/4" - 10UNC Hex Nut
4.	00254	16	3/4" Lockwasher
5.	00482	4	1/2" - 13UNC x 1 3/4" Hex Hd Bolt (Gr.5)
6.	03840	10	20mm-2.5 x 50mm Hex Head Bolt
7.	07681	16	3/4" - 10UNC x 9" Hex Head Bolt (Gr.5)
8.	14095-35	1	Mounting Bracket (Left Side)
9.	14095-35	1	Mounting Bracket (Right Side)
10.	14097-35	1	Spacer Assembly

### BOLT TORQUE SPECIFICATIONS

STANDARD BOLTS:			METRIC BOLTS:	
Size	Grade	Torque	Size	Torque
1/2"	5	75 ft/lbs.	20mm	515 ft/lbs.
3/4"	5	290 ft/lbs.		

**READ complete manual CAREFULLY  
BEFORE attempting operation.**

Please order replacement parts by **PART NO.** and **DESCRIPTION.**