

DEMCO

QUICK TACH

John Deere

8100, 8200, 8300, 8400, 8110, 8210, 8310, 8410,
8120, 8220, 8320, 8420, 8520, 8130, 8230, 8330,
8430, 8225R, 8235R, 8245R, 8260R, 8270R,
8285R, 8295R, 8310R, 8320R, 8335R

AC20081 , Rev 1
12/11

READ complete manual CAREFULLY BEFORE attempting operation.

BOLT TORQUE SPECIFICATIONS		
Size	Grade	Torque
1/2"	5	75 ft/lbs.
3/4"	5	290 ft/lbs.
20MM	10.9	450 ft/lbs.

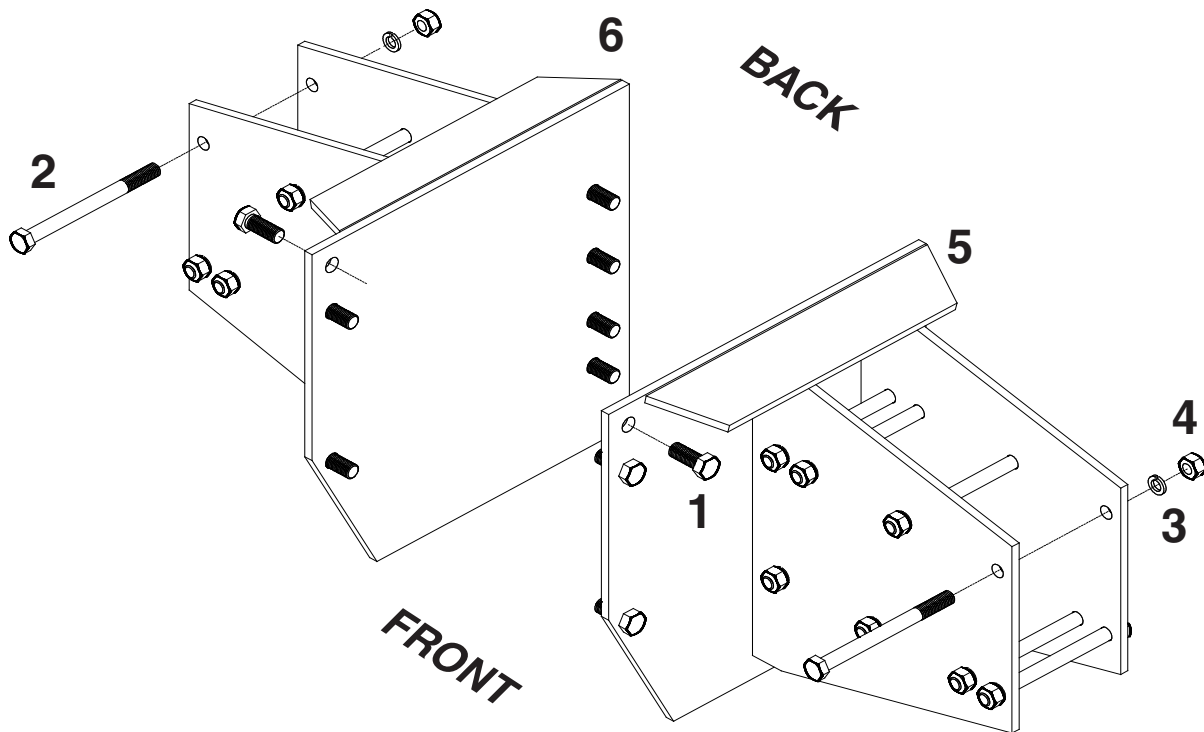

ITEM	PART #	DESCRIPTION	QTY
1	03840	20MM X 2.5MM METRIC BOLT (GR. 8.8)	12
2	07681	3/4-10UNC X 9" HEX HEAD BOLT (GR5)	16
3	00254	3/4" LOCK WASHER	16
4	00253	3/4-10UNC HEX NUT	16
5	10039-72	MOUNTING BRACKET (LEFT SIDE)	1
6	10040-72	MOUNTING BRACKET (RIGHT SIDE)	1

Please order replacement parts by PART NO. and DESCRIPTION.

DEMCO

4010 320th Street • Boyden, IA 51234
www.demco-products.com • 800.543.3626