

DEMCO SIDEQUEST®

05-21
AC20073,rev2

John Deere 8RT
(09-10) 8295RT, 8320RT, 8345RT
(11-13) 8310RT, 8335RT, 8360RT
(14-19) 8320RT, 8345RT, 8370RT
(19-) 8RT 310, 340, 370, 410

**READ complete manual CAREFULLY
BEFORE attempting operation.**

BOLT TORQUE SPECIFICATIONS

SIZE	GR	TORQUE	SIZE	GR	TORQUE
1/2"	5	60 ft/lbs.	3/4"	5	225 ft/lbs.

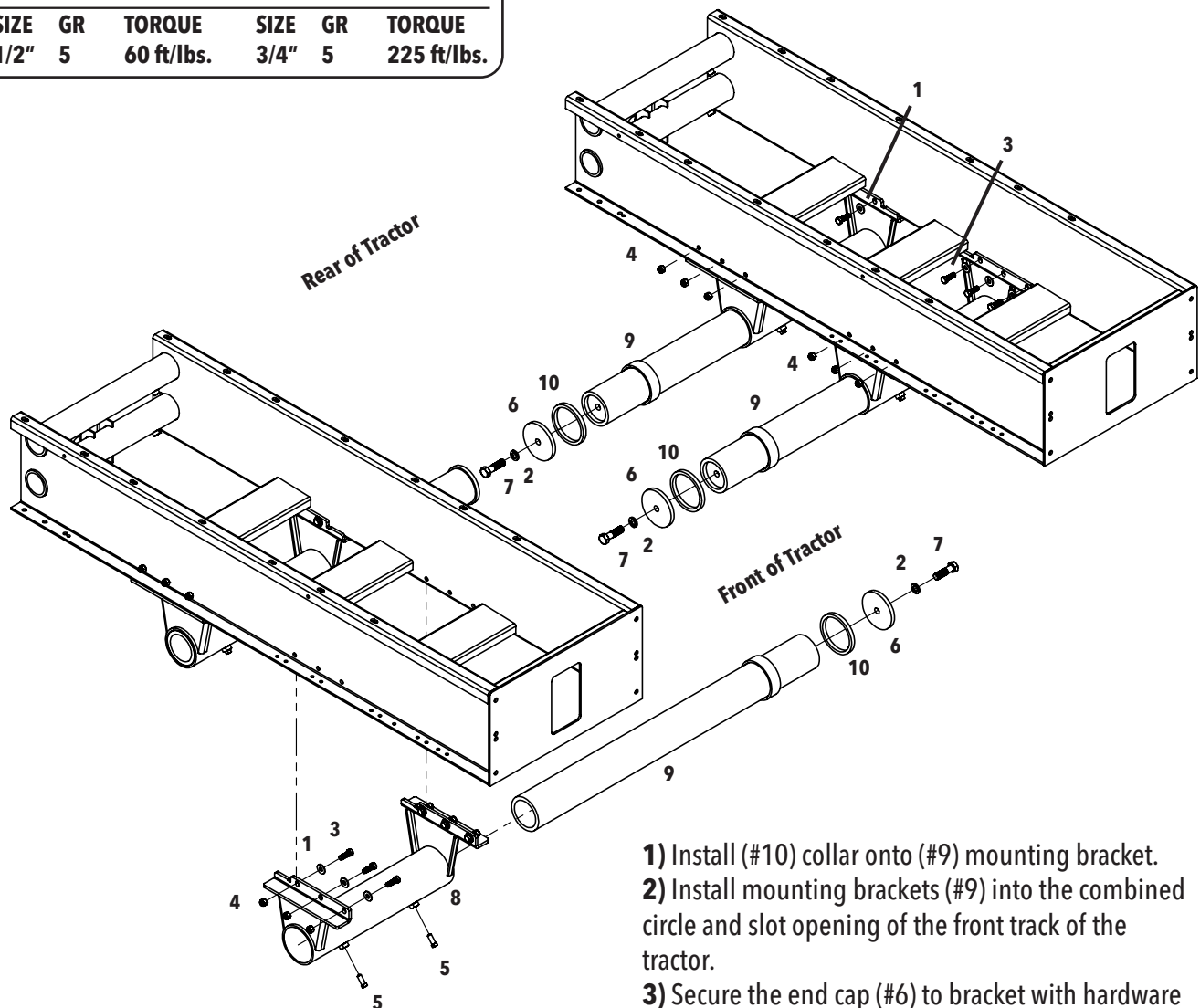

- 1) Install (#10) collar onto (#9) mounting bracket.
- 2) Install mounting brackets (#9) into the combined circle and slot opening of the front track of the tractor.
- 3) Secure the end cap (#6) to bracket with hardware and torque to specifications.
- 4) Slip the tank support brackets (#8) on to mounting brackets (#9). Orient the support brackets so the cutout notches are towards each other.
- 5) Insert set screws into tank support brackets and hand tighten.
- 6) Install tank and saddle on to support brackets and secure with hardware. Position tank with a minimum of 1 inch of clearance from track belt.
- 7) Tighten all remaining fastener hardware.

ITEM	PART #	DESCRIPTION	QTY
1	00085	.50 FLAT WASHER	12
2	00254	.75" LOCKWASHER	2
3	01254	BOLT .50NC X 1.50 GR5 HEX	12
4	02178	NUT, .50NC LOCK, NY. INSERT	12
5	06102	SET SCREW .50NC X 1.25 CUP	8
6	13054-72	END CAP F/ 30 SERIES	4
7	13055	BOLT, .75 NF X 2.75 HEX HEAD GR. 5	2
8	13622-72	SIDEQUEST TANK BRACKET	4
9	13623-72	JD TRACK MOUNTING TUBE BRACKET	4
10.	17322-72	SPACER COLLAR F/ JD 8RT	4

Please order replacement parts by PART NO. and DESCRIPTION

DEMCO • 4010 320th Street • P.O. Box 189 • Boyden, IA 51234

PH: (712) 725-2311 • Toll Free: 1-800-543-3626 • FAX: (712) 725-2380 or 1-800-845-6420

www.demco-products.com