

## COMBINE GRAIN TANK EXTENSION

9E000027 - Case NH MZ350 Tip-up

**PLACE IN COMBINE CAB AFTER ASSEMBLY  
FOR FUTURE REFERENCE.**

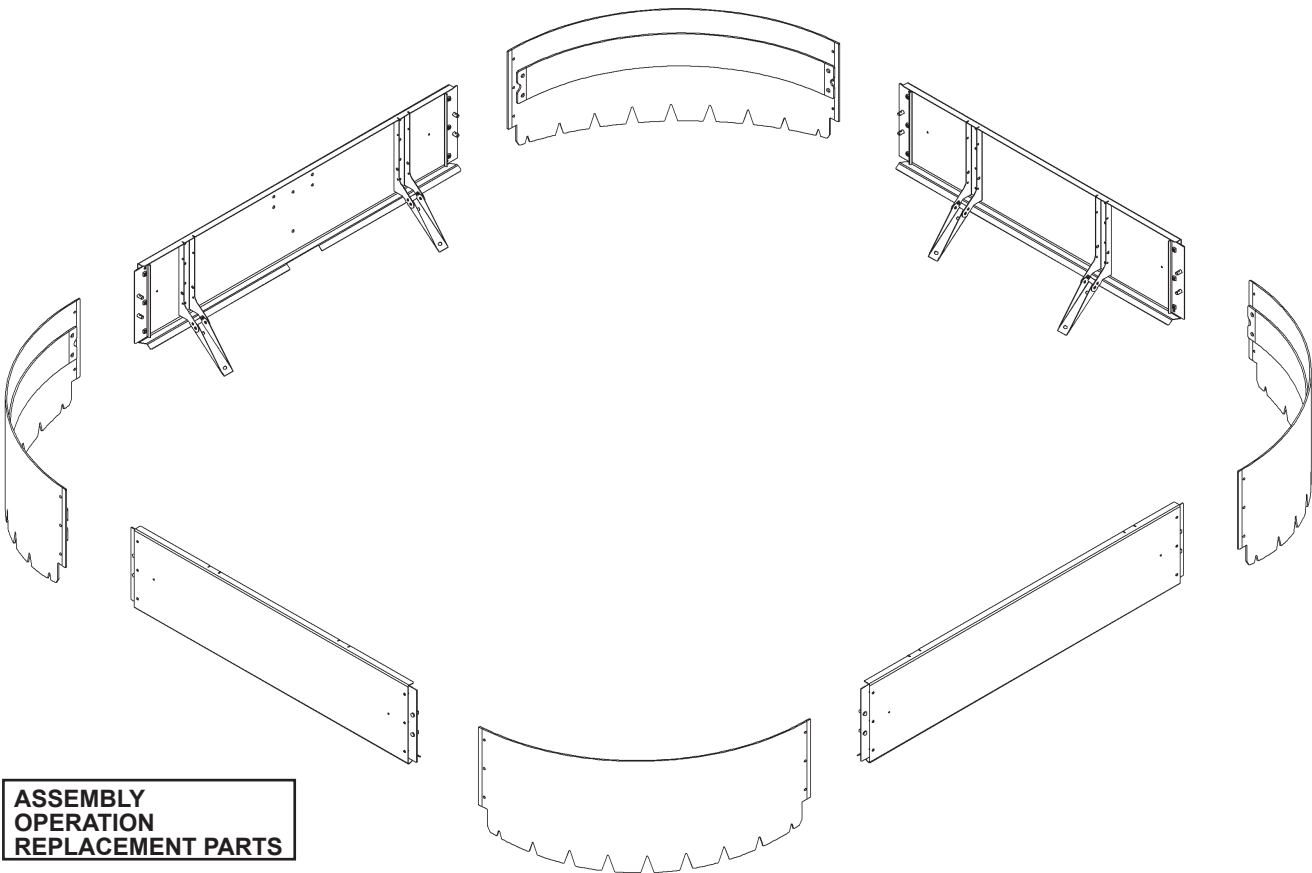

**ASSEMBLY  
OPERATION  
REPLACEMENT PARTS**

## INTRODUCTION

Thank you for purchasing a Demco grain tank extension Tip-Up kit. Proper care and use will result in many years of service.



**WARNING:** TO AVOID PERSONAL INJURY OR DEATH, OBSERVE THE FOLLOWING INSTRUCTIONS:

Ensure that anyone present is clear before applying power to any machinery used in conjunction with a Demco grain tank extension.

Never allow anyone in or near the grain tank of a combine during loading or unloading of grain. The accumulation of grain is dangerous and can cause entrapment, resulting in serious injury or death by suffocation.

Adding a Demco Bin Extension or Tip-Up increases the overall height of your combine. Use caution when operating around trees, buildings, power lines, and when approaching bridges and over passes. Pay attention to height restrictions.

Do not exceed advertised maximum capacity of a Demco grain tank extension.

Beware of low power lines and other obstructions.

## GENERAL INFORMATION

1. Read assembly instructions carefully. Study assembly procedures and all illustrations before you begin assembly. Note which parts are used in each step. This unit must be assembled in proper sequence or complications will result.
2. When placing a parts order, refer to this manual for proper part numbers and place order by **PART NO. and DESCRIPTION.**
3. Whenever terms “**LEFT**” and “**RIGHT**” are used in this manual it means from a position behind combine and facing forward.

## Table of Contents

General information .....	2
Safety, Signal Words.....	3
Product Safety Guidelines .....	4
Product Disclaimer .....	4
Safety Sign Locations .....	5
Safety Sign Care .....	5
Parts Breakdown.....	6-7
Assembly Instructions .....	7-8
Tank Full Sensor .....	8
GPS Bracket .....	8
350MZ & 300MX Step Installation .....	9
Folding Instructions .....	10

## SAFETY

**TAKE NOTE! THIS SAFETY ALERT SYMBOL FOUND THROUGHOUT THIS MANUAL IS USED TO CALL YOUR ATTENTION TO INSTRUCTIONS INVOLVING YOUR PERSONAL SAFETY AND SAFETY OF OTHERS. FAILURE TO FOLLOW THESE INSTRUCTIONS CAN RESULT IN INJURY OR DEATH!**



**THIS SYMBOL MEANS  
ATTENTION  
BECOME ALERT  
YOUR SAFETY IS INVOLVED!**

### **SIGNAL WORDS**

Note use of following signal words **DANGER**, **WARNING**, and **CAUTION** with safety messages. The appropriate signal word for each has been selected using the following guidelines:

**DANGER:** Indicates an imminently hazardous situation that, if not avoided, will result in death or serious injury. This signal word is to be limited to most extreme situations typically for machine components which, for functional purposes, cannot be guarded.

**WARNING:** Indicates a potentially hazardous situation that, if not avoided, could result in death or serious injury, and includes hazards that are exposed when guards are removed. It may also be used to alert against unsafe practices.

**CAUTION:** Indicates a potentially hazardous situation that, if not avoided, may result in minor or moderate injury. It may also be used to alert against unsafe practices.



## **PRODUCT SAFETY GUIDELINES**

Every year many accidents occur which could have been avoided by a few seconds of thought and a more careful approach to handling equipment. You, the operator, can avoid many accidents by observing the following precautions in this section. To avoid personal injury, study the following precautions and insist those working with you, or you yourself, follow them.

Replace any caution, warning, danger or instruction safety decal that is not readable or is missing. Location of such decals is indicated in this booklet.

Review safety instructions with all users annually.

Operator should be a responsible adult. **DO NOT ALLOW PERSONS TO OPERATE OR ASSEMBLE THIS UNIT UNTIL THEY HAVE DEVELOPED A THOROUGH UNDERSTANDING OF SAFETY PRECAUTIONS AND HOW IT WORKS.**

Do not paint over, remove, or deface any safety signs or warning decals on your equipment. Observe all safety signs and practice instructions on them.

Never exceed limits of a piece of machinery. If its ability to do a job, or to do so safely is in question **DON'T TRY IT.**

Adding a Demco Bin Extension or Tip-Up increases the overall height of your combine. Use caution when operating around trees, buildings, power lines, and when approaching bridges and over passes. Pay attention to height restrictions.

Fold and secure (if needed) the grain tank extension panels when transporting the combine to avoid contact with low power lines and other obstructions.

Ensure that any additional bracing and safety equipment have been installed according to this manual. (Some models do not require additional bracing or safety equipment)

Never exceed the maximum advertised capacity of the grain tank extension. By doing so you risk damage to the grain tank extension and combine.

## **PRODUCT DISCLAIMER**

Increasing the grain tank capacity of any combine by use of this product is at the discretion of the owner. Increasing the grain holding capacity of any combine may affect the structural aspects of the combine as well as drive line components and tires. Although Demco has included additional support bracing on selected models, it does not assume liabilities, or make any warranties pertaining to the structural stability or performance of any combine. See the combine owners/operators manual for additional combine specifications and safety information not listed in this manual.



## SAFETY SIGN LOCATIONS

Types of safety sign and locations on equipment are shown in the illustration below. Good safety requires that you familiarize yourself with various safety signs, type of warning, and area or particular function related to that area, that requires your SAFETY AWARENESS.

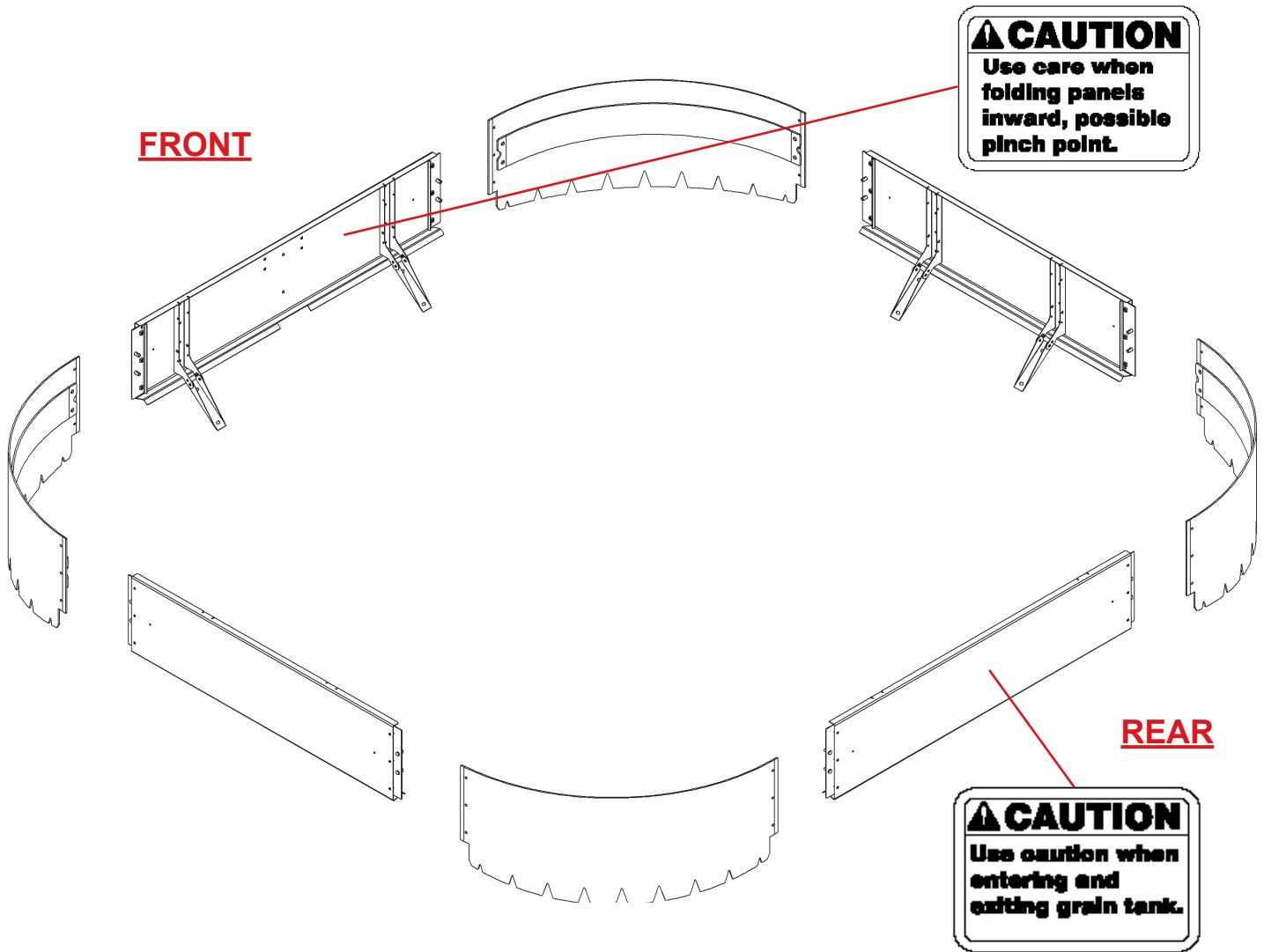

## SAFETY SIGN CARE

- Keep safety signs clean and legible at all times.
- Replace safety signs that are missing or have become illegible.
- Replacement parts that displayed a safety sign should also display current sign.
- Safety signs are available from your distributor, dealer parts department, or factory.

# Tip-Up Kit Parts Breakdown

## 350MZ Tip-Up Kit for Case NH w/ 27" Panels

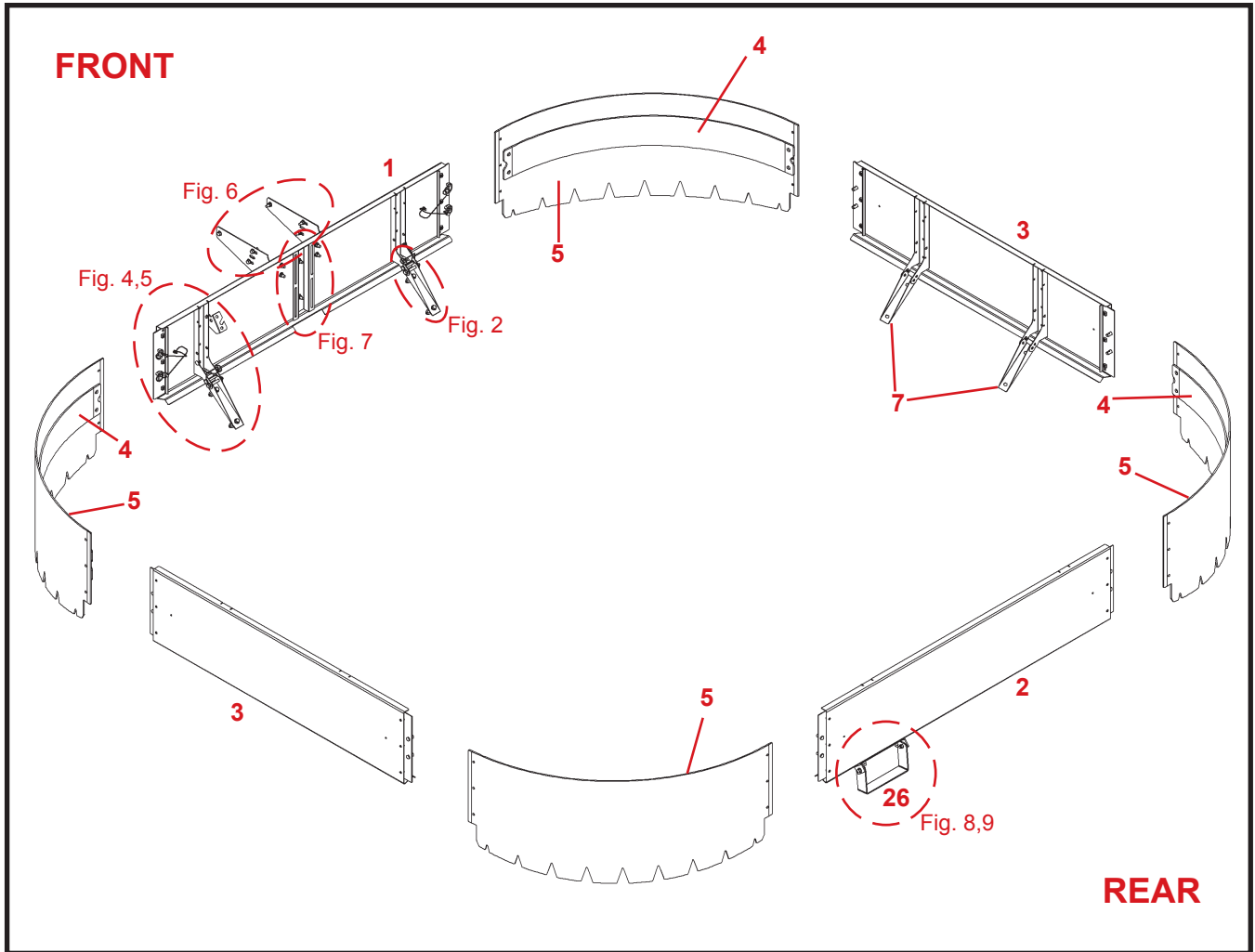

Figure 1

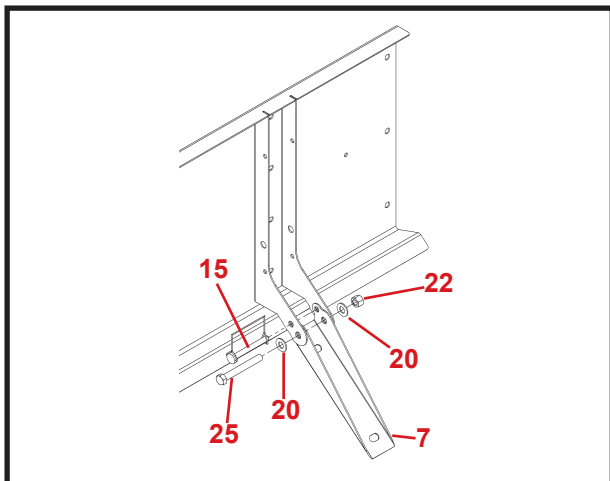

Figure 2

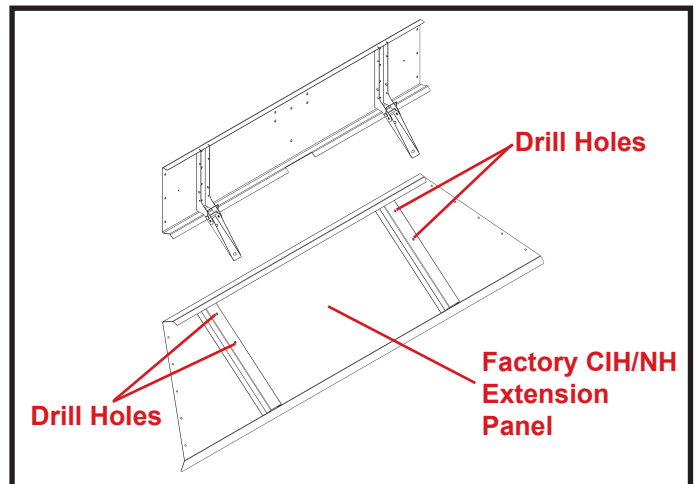

Figure 3

## PARTS LIST

Please order replacement parts by PART NO. and DESCRIPTION.

REF. NO.	PART NO.	QTY.	DESCRIPTION
1.	R5E000100Q1	1	CNH Front Tip-Up Panel Assy. 350MZ w/ 27" Panel
2.	R5E000101Q1	1	CNH Rear Tip-Up Panel Assy. 350MZ w/ 27" Panel
3.	R5E000102Q1	2	CNH Left & Right Tip-Up Panel Assy. 350MZ w/ 27" Panel
4.	1AR00000063	4	CNH Tip-Up Plastic Support, 350 CNH w/ 27" Panel
5.	3E000172	4	CNH Tip-Up Rubber Corner, 350 CNH w/ 27" Panel
6.	R3E000003Q1	1	Base Light Bracket
7.	R3E000149Q1	8	CIH Bottom Hinge STD, 300MX w/ 32" Panel
8.	R3E000151Q1	1	CNH Tip-Up Full Bin Sensor Bracket
9.	R5E000085Q1	8	CNH Tip-Up Clamp Angle Assy.
10.	R5E000086Q1	1	CNH Tip-Up GPS Bracket Assy.
11.	R30007153Q1	1	CNH GPS Bracket
*12.	1AEX0015243	1	Case / NH 3-Way Full Tank Sensor Harness
13.	1AF031DKA00	24	Nylon Lanyard
14.	1AF032D0000	16	Press Rivet for Nylon Lanyard
15.	1AF026EBAH0	8	5/16" x 2-1/4" Lynch Pin
16.	1AF034CAA10	16	3/16" x 1-9/16" Lynch Pin
17.	1AFC37D00H0	2	1/4"-20 x 1/2" Flange Bolt
18.	1AFC08D0000	2	1/4"-20 Flange Nut
19.	1AFC37EAA05	24	5/16" x 1" Flange Bolt
20.	1AF009F000C	48	3/8" SAE Flat Washer
21.	1AFC08F0000	12	3/8" Flange Nut
22.	1AFC18F0000	28	3/8"-16 Hex Nut Nylock
23.	1AFC37FAA05	16	3/8"-16 x 1" Hex Flange Bolt
24.	1AFC12FBAH5	16	3/8"-16 x 2-1/2" Hex Bolt
25.	1AFC12FCA05	8	3/8"-16 x 3" Hex Bolt

\* Indicates items not shown in illustrations

## **ASSEMBLY INSTRUCTIONS**

### **STEP 1:**

Fasten the bottom Tip-Up Hinges to the Tip-Up Panels using the 3/8" x 3" hex bolts, 3/8" flat washers, and 3/8" nylon lock nuts. See Figure 2.

### **STEP 2:**

Once the Front, Rear, Left, and Right Tip-Up Panels have the Hinges attached, install the 5/16" x 2-1/4" lynch pins to lock all the Hinges in position. See Figure 2. This will make the hinge point fixed or rigid.

### **STEP 3:**

Starting with the Front Tip-Up Panel and Hinges, set them on the top edge of the Front Factory Extension Panel. Once the Tip-Up is centered on the Factory Panel, the Hinges should be located directly on the Factory Panel ribs. Using a center punch, mark the center of the 2 mounting holes on each hinge. Then using a 13/32" drill bit and electric drill, drill holes completely through the panels as shown in Figure 3. Complete the same procedure on the remaining panels.

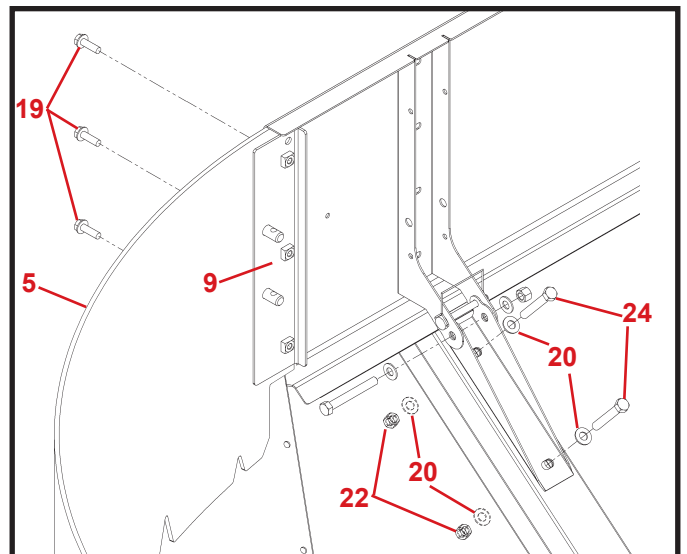

Figure 4



**ATTENTION:** During assembly ensure the following safety decals are located correctly. See illustration on page 5.



**NOTE:** All steel Tip-Up panels must be installed first to ensure proper fit.

**STEP 4:**

Fasten the bottom Tip-Up Hinge to the Factory CNH Extension Panels using the 3/8" x 2-1/2" hex bolts, 3/8" flat washers, and 3/8" nylon lock nuts as shown in Figure 4.

**NOTE:** DO NOT over tighten nuts and distort hinge component, but ensure nylon lock nut fully engages bolt threads.

**STEP 5:**

Once the front, rear, and side panels have been completely installed, the rubber corners can be attached. Insert the rubber corners to mate with the INSIDE of the Tip-Up Panels and on top of the CNH Factory Rubber Corners. Place the Clamp Angle assemblies over the ends of the Tip-Up rubber corners, and attach with 5/16" x 1" hex flange bolts. See Figure 4.

**STEP 6:**

Place plastic supports over the clamp angles and fasten with one 3/16" lynch pin per clevis pin. See Figure 5. Plastic supports will and need to fit very tightly.

**STEP 7:**

Align lanyards and press rivets as shown in Figure 5. Loop and lock the end of the lanyard around the ring of the 3/16" lynch pins and the 5/16" lynch pin, then proceed to pin the panel joints together.

**LIGHT BRACKET & LIGHT**

Mount the light bracket on the right hinge of the front Tip-Up panel. Use one 1/4"x1/2" flange bolt and one 1/4" flange nut. See Figure 5. Mount OEM light on bracket using original hardware.

**GPS BRACKET**

Fasten the provided GPS bracket to the outside of the front Tip-Up panel using four 3/8" x 1" hex flange bolts and four 3/8" flange nuts. See Figures 1 & 6.

**TANK FULL BIN SENSOR**

Attach the tank full bin sensor bracket to the front Tip-Up panel with two 3/8" x 1" hex flange bolts and two 3/8" flange nuts. Mount the tank full bin sensor to the desired height with the original hardware. See Figure 7.

Located on outside of rear panel.

Located on inside of front panel.

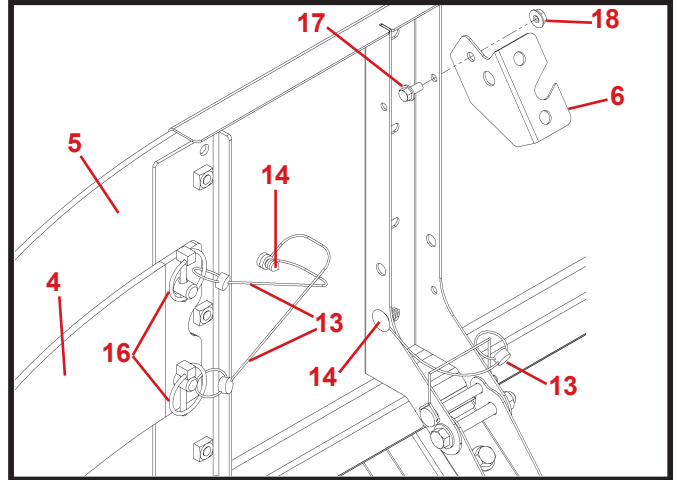

Figure 5

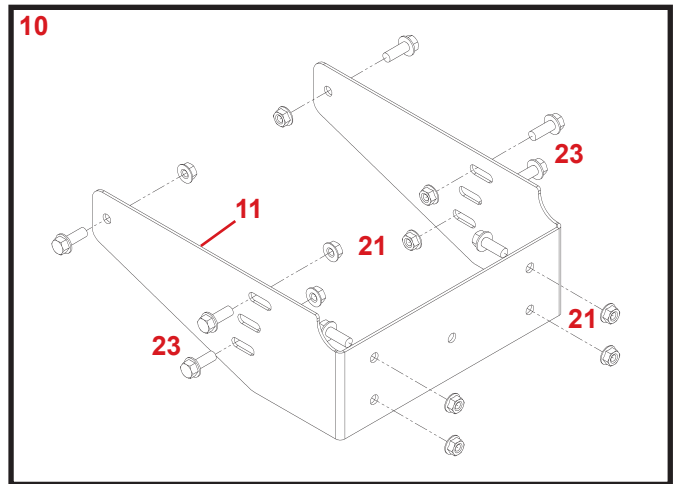

Figure 6

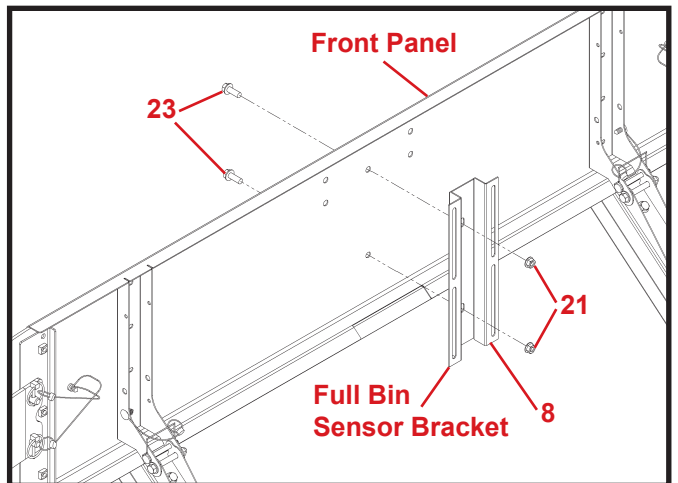

Figure 7



## 350MZ & 300MX Step Installation

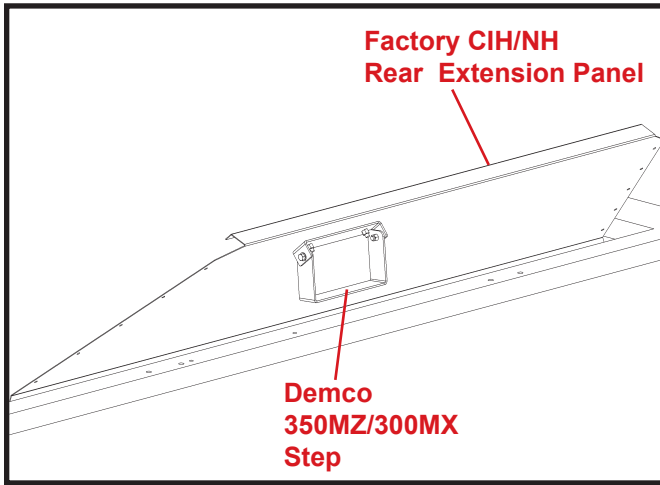

Figure 8

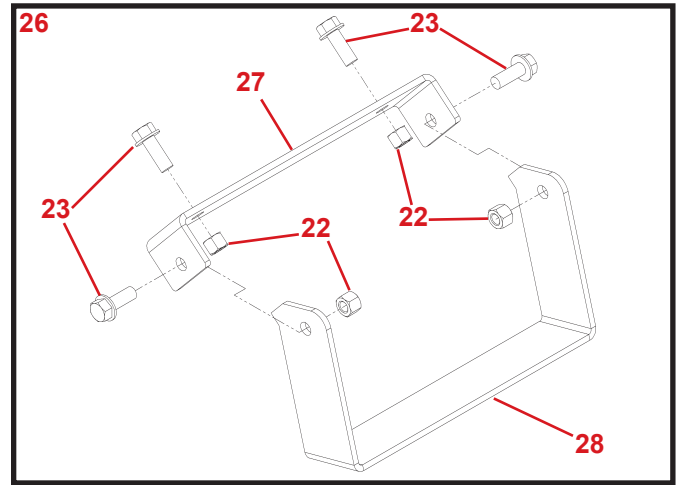

Figure 9

### PARTS LIST

Please order replacement parts by PART NO. and DESCRIPTION.

REF. NO.	PART NO.	QTY.	DESCRIPTION
26.	R5E000089Q1	1	CIH Tip-Up Step Assy., 300MX w/ 32" Panel
27.	R3E000153Q1	1	CIH Step Bar, Base, 300MX w/ 32" Panel
28.	R3E000154Q1	1	CIH Step Bar, Flip Down, 300MX w/ 32" Panel

**Note:** The parts listed on this page are interchangeable and can be used on both the Demco 350MZ & 300MX Tip-Up Kits.

### **STEP 1:**

First, assemble the step with two 3/8" x 1" hex flange bolts and two 3/8" nylon lock nuts as shown in Figure 9. The step should pivot freely. Place step assembly on the rear panel of the Factory CNH Extension. Locate the step in a spot that is accessible for the user and allows the tip-up panel to fold down. Mark hole placements with a magic marker. See Figure 8.

**Caution:** Beware of the placement of the existing step located on the inside of the panel.

### **STEP 2:**

Use a 13/32" diameter drill bit and electric drill to put two holes through the Rear Extension Panel.

### **STEP 3:**

Fasten the step to the rear Extension panel using the two 3/8" x 1" hex flange bolts and two 3/8" nylon lock nuts. See Figure 9.

# FOLDING INSTRUCTIONS

## STEP 1:

Remove the 3/16" lynch pins from the clamping angles on all corners of the tip-up.

## STEP 2:

Detach the plastic corner supports and place them in the bottom of the combine tank.

## STEP 3:

Remove all of the 5/16" x 2-1/4" lynch pins from hinge connections on the Front, Rear, Left, and Right Tip-Up Panels.



## STEP 4:

Start by folding the Front Panels into the tank first. Then fold the Rear Panels into the tank. The Left and Right Side Panels should fold in last.

## Please Note:

Internal bracing, ladders, and augers may prevent the grain tank extension from folding completely flat. Use extreme care and caution when entering sheds or while transporting your combine.

# **DEMCO**

4010 320th St., Boyden, IA. 51234

Phone: (712) 725-2311

Fax: (712) 725-2380

Toll Free: 1-800-54DEMCO (1-800-543-3626)

**Demco warranty policies, operator manuals, and product registration  
can be found online:**

**[www.demco-products.com](http://www.demco-products.com)**

