



Doing Our Best to Provide You the Best

8C000403, A

02/24

SIDE DUMP

QUAD AXLE - AIR RIDE

9CCR474ARRL3726

47' Chassis, 37' Tub, With Rear Lift

9CCR474ARFLRL3726

47' Chassis, 37' Tub, With Front Lift & Rear Lift

9CCR474ARFLRLS3726

47' Chassis, 37' Tub, With Front Lift & Rear Lift Steer

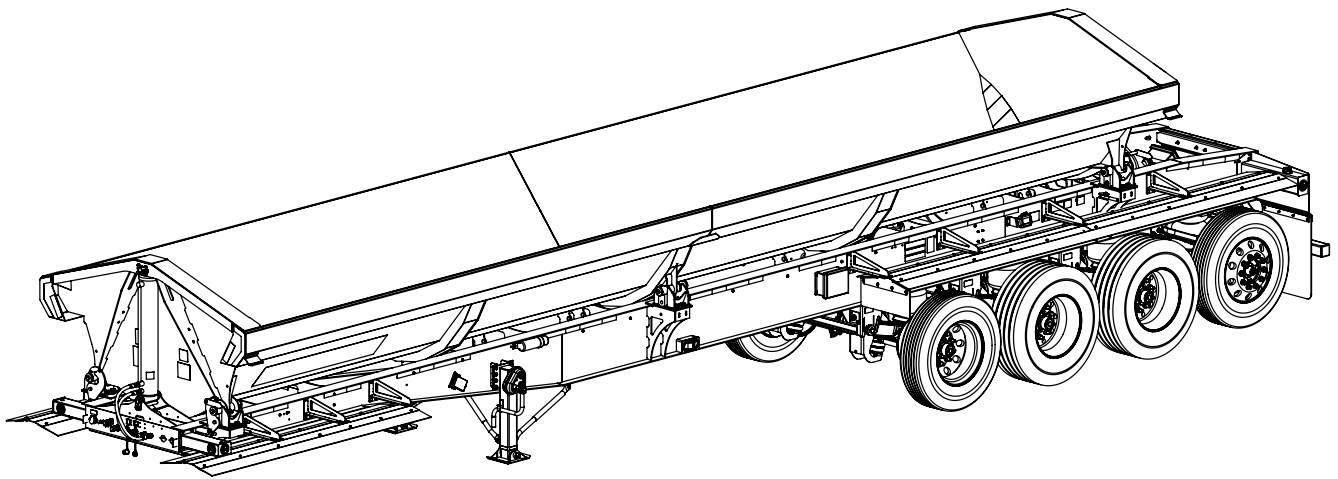

PARTS MANUAL

Overview 2
Side Dump Information 3
How To Order Parts 3

Replacement Parts 4
9-Pin Connectors..... 4
ABS Brakes -- Haldex 6
Air Supply Parts 12
Document Box and Manual Holder 15
Electrical System 16
Fender Parts -- Front 20
Fender Parts -- Rear 21
Fifth Wheel Grease Components 25
Hydraulic System 26
Jack 30
Landing Gear -- SAF-Holland 31
Pivot Latch Components 33
Remote Grease Zerk Components 34
Safety Decals/Reflectors 35
Suspension Parts -- CBX23 Standard 37
Suspension Parts -- CBX23 PosiLift™ 38
Tub Components 39

Optional Parts 41
Center Mud Flap Options 42
Electric Over Hydraulic Control Option..... 44
Electric Tarp Option -- Aero 50
Electric Tarp Option -- Roll-Rite 60
Rear Attachment Options 73
Rear Strobe Light Option 79

Side Dump Information

This parts manual is for the Demco Side Dump Models:

9CCR474ARRL3726 47' Chassis, Air Ride, 37' Tub, With Rear Lift

9CCR474ARFLRL3726 47' Chassis, Air Ride, 37' Tub, With Front Lift & Rear Lift

9CCR474ARFLRLS3726 47' Chassis, Air Ride, 37' Tub, With Front Lift & Rear Lift Steer

Record the following information for future reference in ordering replacement parts or additional options.

Serial Number _____

Date Purchased _____

Dealer Information _____

Serial Number

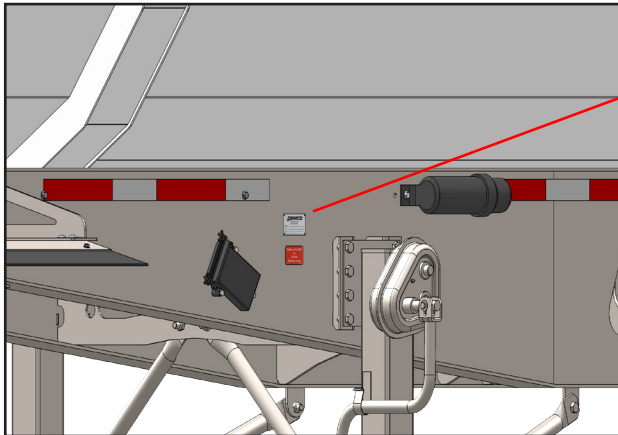

Example: VIN Number Description

57CKS4029CT627045

Demco
Side Dump
40' Length
No. of Axles
Check Digit
Model Year
Demco Identifier
Trailer Sequence Number

In addition to the VIN number Demco has placed a coded unit number on the chassis and the tub.

How To Order Parts

Use this manual to help determine the part number needed, then contact your dealer with the model number, serial number, and part information. They can order the part(s) directly from Demco.

9-Pin Female Connector #1AEAP4546 Trailer Harness (View From Front)

<i>Position</i>	<i>Color</i>	<i>Functions</i>
1	RED	TUB DUMP
2	WHT	TUB - RETURN
3	GRN	LIFT AXLE DOWN
4	BLK	GROUND - CENTER PIN
5	ORG	TUB SWITCH POWER
6	RED	TARP - UNCOVER
7	BLK	TARP - COVER
8	ORG	+ POSITIVE (Tarp Over-Ride)
9	GRN	TARP LOCK OUT - SENSOR

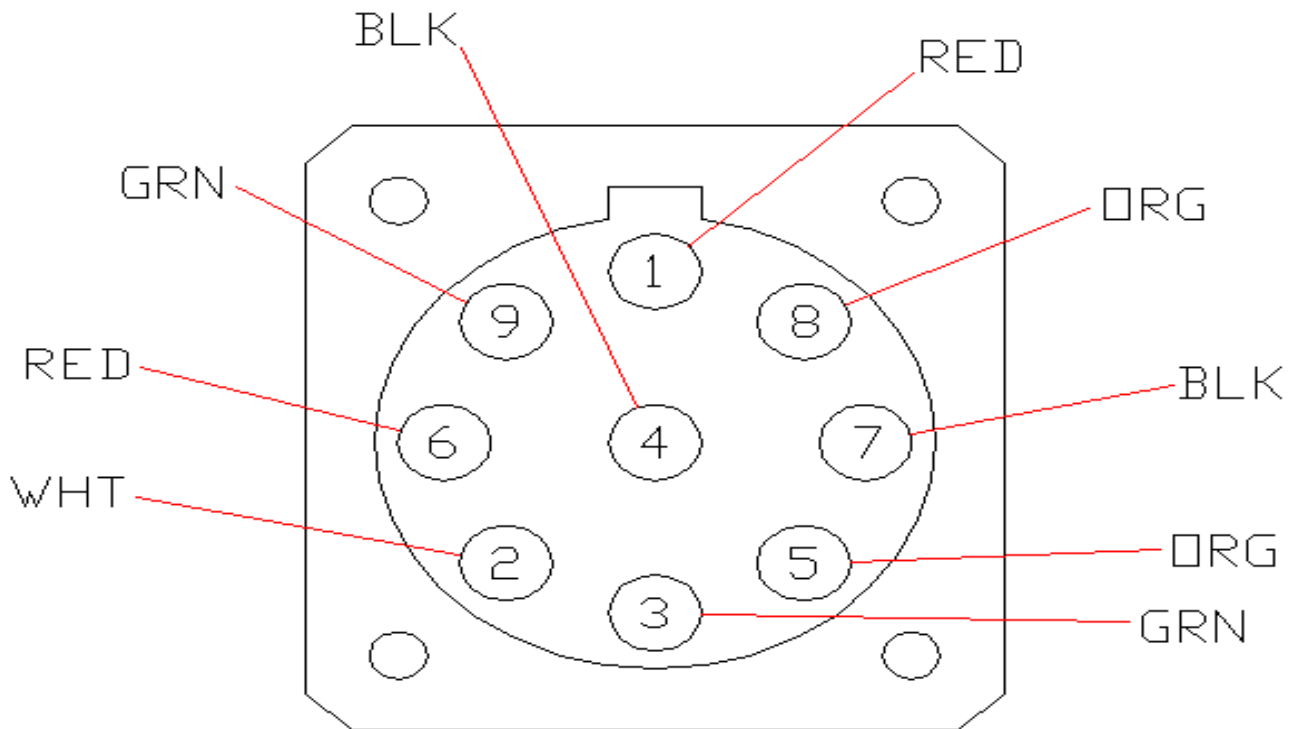

9-Pin Male Connctor #1AEAP4548 Control Box (View From Rear)

Position	Color	Functions
1	RED	TUB DUMP
2	WHT	TUB - RETURN
3	GRN	LIFT AXLE DOWN
4	BLK	GROUND - CENTER PIN
5	ORG	TUB SWITCH POWER
6	BLU	TARP - UNCOVER
7	WHT/BLK	TARP - COVER
8	RED/BLK	+ POSITIVE (Tarp Over-Ride)
9	GRN/BLK	TARP LOCK OUT - SENSOR

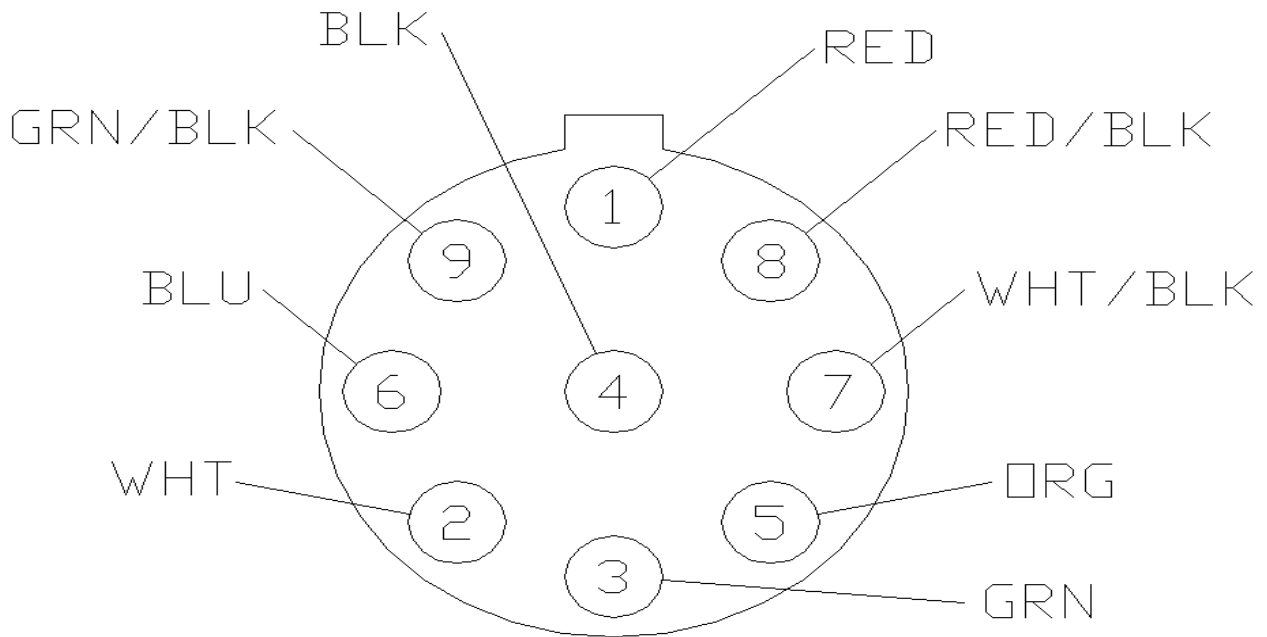

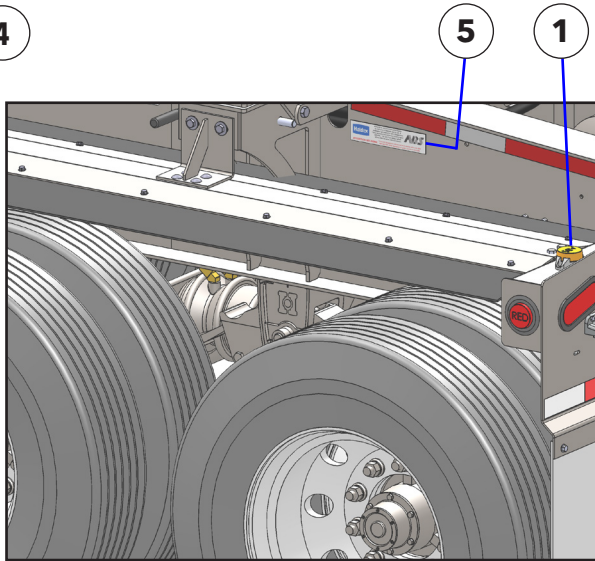
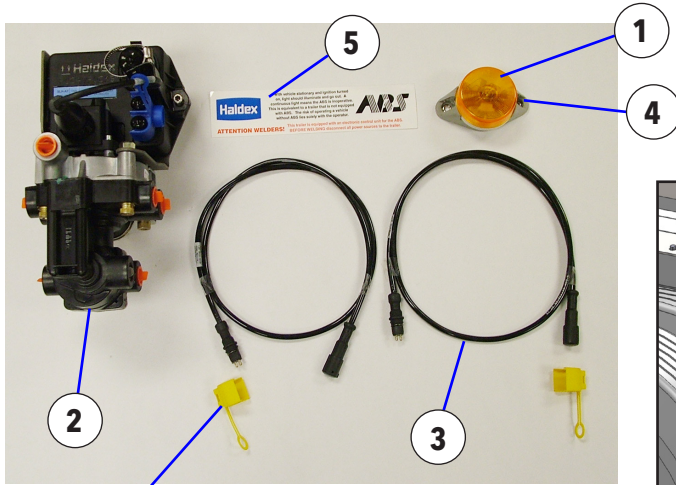

Haldex
 (816) 891-2470
 Valve Model: AL430624
 ECU Model: AL919323
 Visit Company's website for add'l info at:
<https://www.haldex.com/en/North-America/>

ABS-1 Axle 2S1M System			
BOM ID	Qty	Item No	Description
1	1	1AEAP4301	ABS LIGHT BRACKET
2	3	1ABAP3528	VALVE, FFABS, 3/4" NPT, HALDEX N9001JB
3	1	1ABAP3754	ABS SENSOR EXT. CORD, 1 METER
4	2	1AEAP4302	ABS LIGHT
5	1	1AQAP4304	DECAL, ABS LIGHT/ATTN WELDERS
6	1	1AAAP4308	RETAINING CLIP, ABS SENSOR PLUG

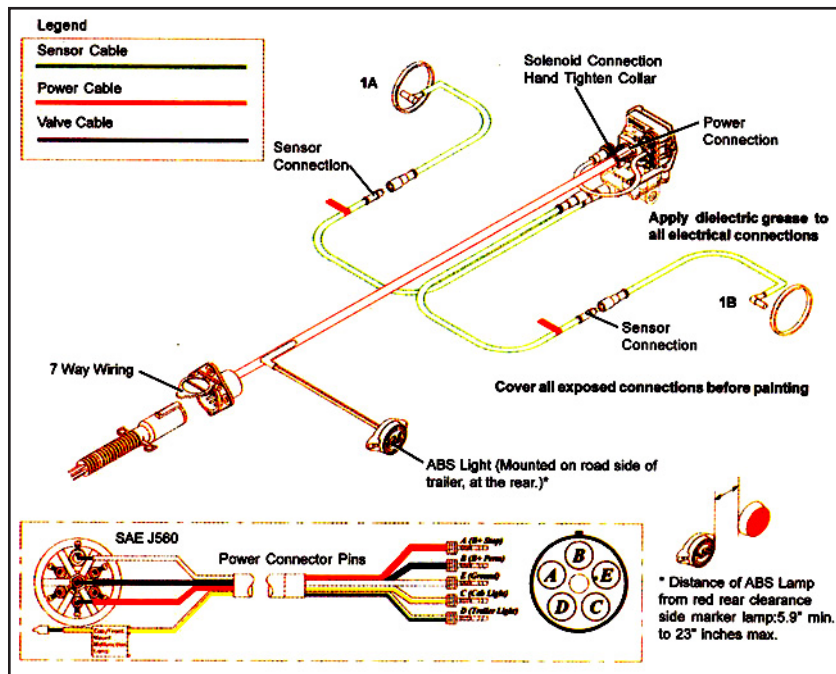

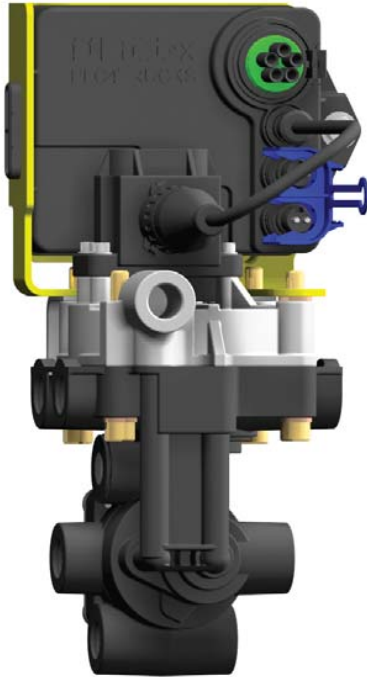

PLC Select ABS (1M)

***Installation/Service Manual
for
2S/1M Systems***

PLC Select 1M

PLC Select 1M & 2M Valve Orientation



The ABS Valve Solenoid must be installed as shown below

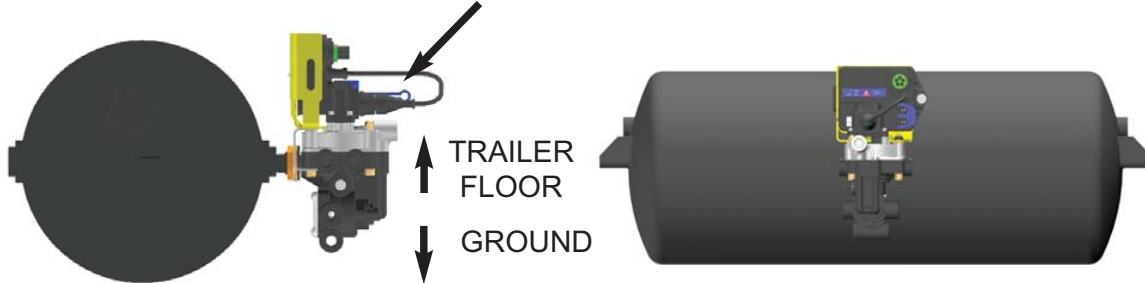

Typical tank mount valve orientation

1. Install fittings into valve. Sealant is not required on plastic threads or on fittings that go into plastic. **DO NOT** use teflon tape on fittings. It can break off and contaminate the air system. Liquid pipe sealant is approved for use if required.
2. For plastic ports, hand tighten fittings then rotate 1 to 1-1/2 additional turns. The maximum torque valve allowed is 210 in-lb.
3. Install valve nipple into reservoir port. Use 7/8" wrench to tighten the nipple.
4. Using a 1-1/2" wrench tighten the jam nut to 30 ft. lb, while holding the nipple with a 7/8" wrench.(see detail below).
5. Attach hoses to appropriate brake chambers. Use liquid thread sealant sparingly on all fittings (Loctite PST565 or equivalent).

Note: *If frame mounted follow same procedure for valve orientation. Valve solenoid on a 2-port relay, 6-port relay or FFABS must be facing up when the trailer is in normal operation or service/ABS performance could be effected.*

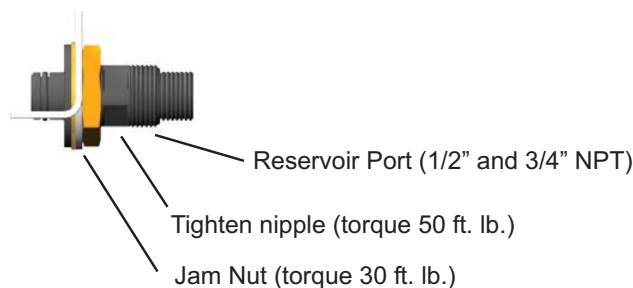

Warning: *Proper installation orientation shown above; otherwise, warranty is void. Installation behind the tank is recommended, facing the back of the trailer.*



PLC Select FFABS 2S/1M
(4 Service Delivery Ports/ 4 Spring Brake Ports)

- Air suspension typically have the sensors on the rear axle
- Spring suspension typically have the sensors on the front axle

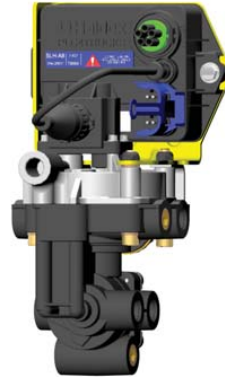

PLC Select 1M (FFABS)

Plumbing Schematic (2S/1M)
Top View

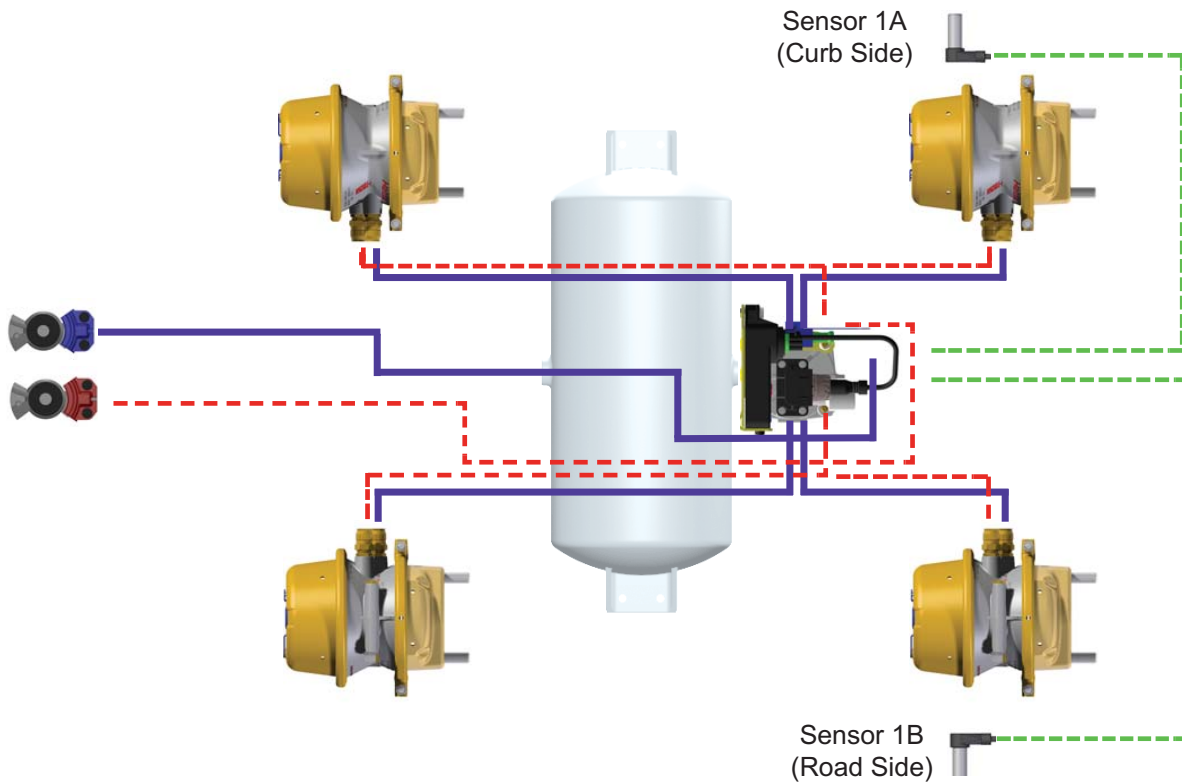

Legend:

Service/Control Line	
Emergency/Supply Line	
Sensor Line	

AIR BRAKE COMPONENTS AND SYSTEM SCHEMATIC ARE DESIGNED TO ALLOW COMPLIANCE WITH FMVSS 121.

THIS SCHEMATIC IS FOR INFORMATION PURPOSE ONLY. IT IS THE VEHICLE MANUFACTURERS ULTIMATE RESPONSIBILITY TO CERTIFY THEIR SYSTEM MEETS ALL APPLICABLE REGULATIONS.

PIPE NIPPLES USED TO MOUNT BRAKE VALVES MUST BE HEAVY WALL TYPE PER SAE J514.

PLC Select 1M



ABS Power Cord - Pin Out

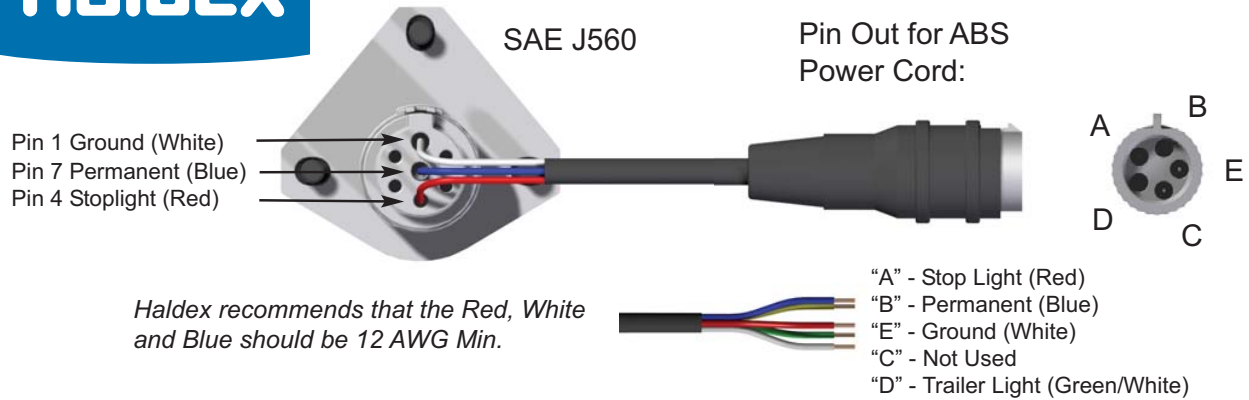

Note: Federal regulations mandate that new trailers, built after 3/1/2001, have the capability to provide an ABS fault signal from the trailer ABS into the tractor for an In-Cab trailer ABS Lamp. Option (1) is through Industry standard "PLC4Trucks" multiplexing (the signal is carried on Pin 7)

PLC Select 1M ECU Overview

Correct location of the speed sensors at the wheel ends is critical for proper ABS operation and troubleshooting. The PLC Select 1M will adjust the braking air pressure in response to the input from the speed sensors. Incorrect installation or location of speed sensors, sensor block clips and exciter rings will result in poor ABS performance or sensors crossed leading to incorrect diagnostics troubleshooting.

The figure below shows the correct power and speed sensor connections on the PLC Select 1M ECU (Electronic Control Unit).

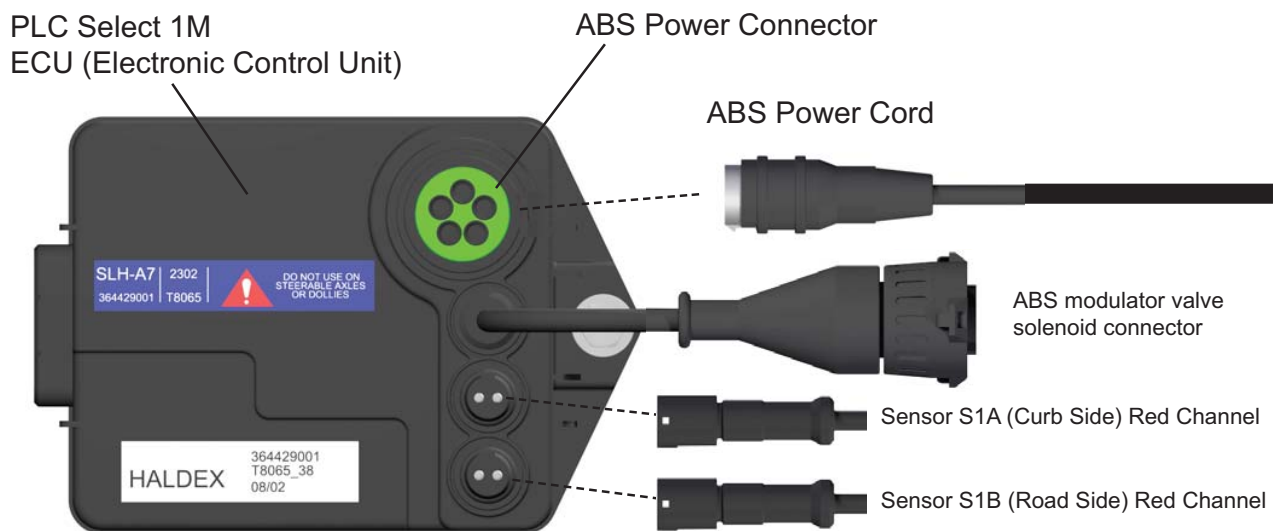

Note: When installing and servicing always apply small amount of dielectric grease to all electrical connections.

PLC Select 1M

2S/1M System Wiring - PLC Select



Note: Cover all exposed electrical connections before painting



*Distance of ABS Light from Red rear clearance side marker light is 5.9" inches to 23" inches max.

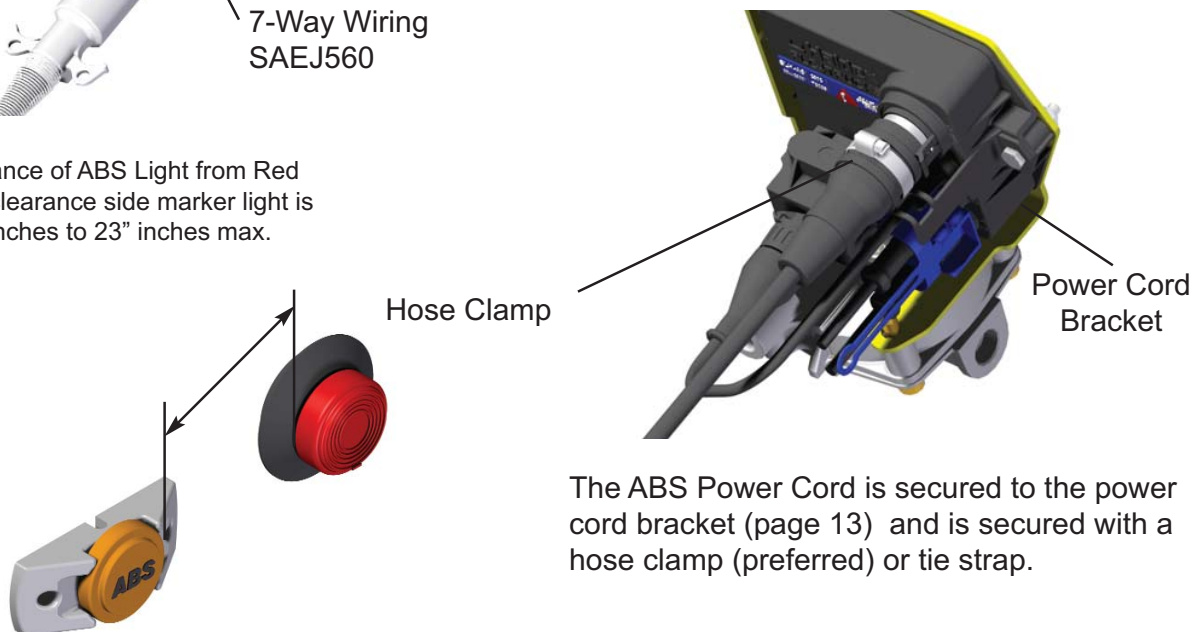

PLC Select 1M

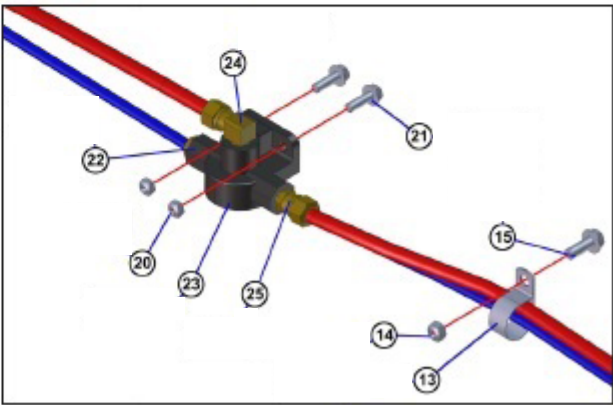
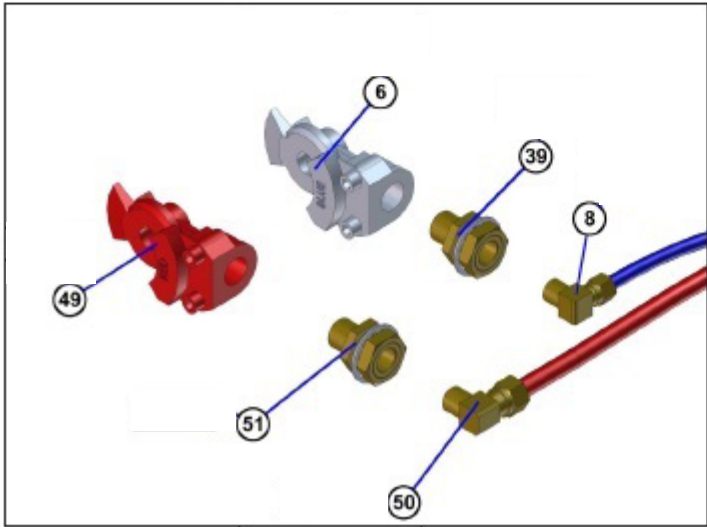
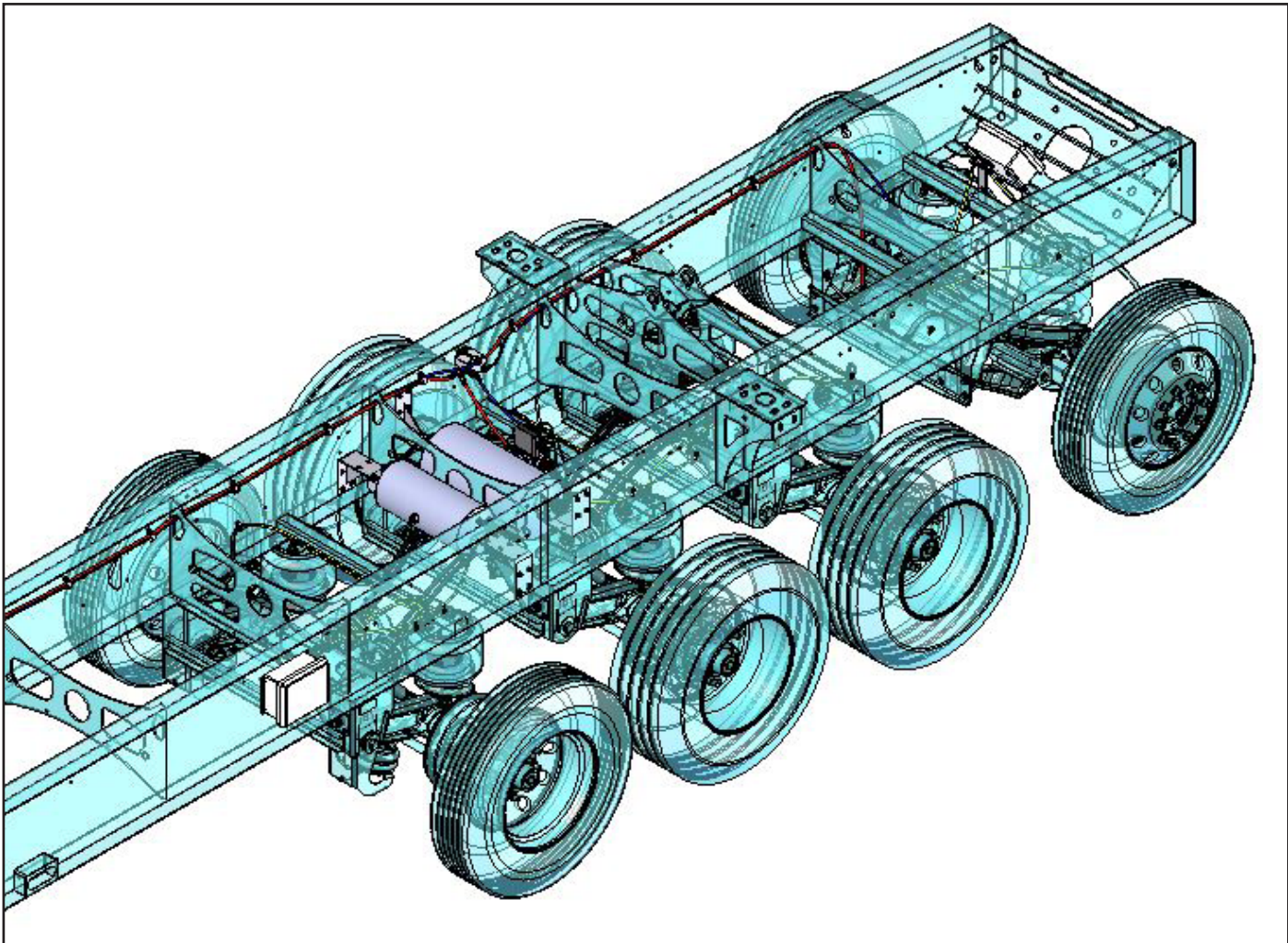

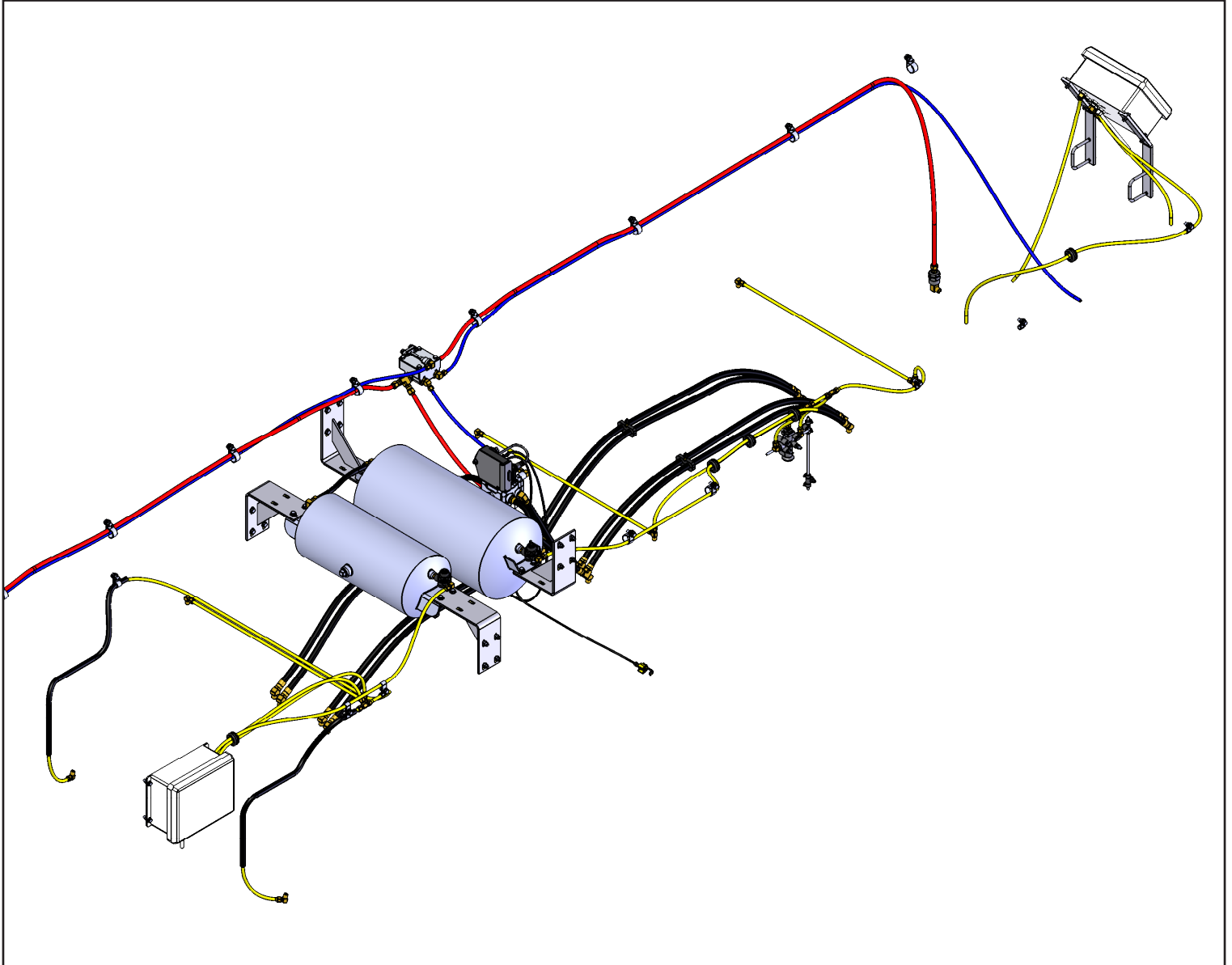

PARTS LIST FOR 47' CBX AIR RIDE QUAD-AXLE

BOM ID	Qty	Item No	Description
1	2	1AAAP4306	VALVE ASSEMBLY, LIFT AXLE CONTROL W/ BOX & INSTRUCTIONS
2	15	1ABOCL38140	ELBOW, 1/4" MP X 3/8" TUBE, 90, BRASS
3	4	1ABOCL38380	ELBOW, 3/8" MP X 3/8" TUBE, 90, BRASS
4	1	1ABOCS38140	ADAPTER, 1/4" MP X 3/8" TUBE, STRT, BRASS
5	3	1ABOCT38380	TEE, UNION, 3/8" TUBE
6	2	1ABODDRAIN0	DRAIN COCK, 1/4" NPT
7	1	1ABOG0000E0	GLADHAND, EMERGENCY, RED
8	1	1ABOG0000S0	GLADHAND, SERVICE, BLUE
9	50	1ABOT0375B0	3/8" BRAKE LINE - BLUE
10	1	1ABAP3524	AIR TANK, 2800 CU IN
11	49	1ABAP3537	NYLON TUBING, RED, 1/2"
12	1	1ABAP3554	AIR TANK, 1488 CU IN
13	57	1ABAP3683	NYLON TUBING, YELLOW, 3/8"
14	1	1ABAP3686	TUBE, 3/8" X 3/8" MP, ELBOW
15	12	1ABAP3688	STREET ELBOW, 3/8". 45 DEGREE
16	4	1ABAP3698	HEX BUSHING, 1/2 X 3/8, BRASS
17	4	1ABAP3745	HOSE, 1/2 AIR BRAKE X 20, 3/8MP-3/8MPX
18	1	1ABAP3752	QUICK RELEASE VALVE
19	2	1ABAP4199	TUBE, 1/2 X 3/8 MP, 90, NUT & FERRULE, BRASS
20	6	1ABAP4200	TUBE, 1/2 X 3/8 MP, STRT, NUT & FERRULE, BRASS
21	1	1ABAP4201	NIPPLE, HEX REDUCER, 3/8 MP X 1/4 MP, BRASS
22	2	1ABAP4243	TUBE, 5/8" X 3/8" MP, 90, NUT & FERRULE, BRASS
23	-	1ABAP4244	NYLON TUBING, BLACK 5/8"
24	4	1ABAP4392	HOSE CLAMP, 2 HOLE, 1/2 AIR BRAKE
25	4	1ABAP4471	HOSE, 1/2 AIR BRAKE X 52, 3/8MP-3/8MPX
26	6	1AEAP3805	1/2" HOSE SUPPORT CLAMP, 3/8" BOLT
27	2	1AEAP3806	3/4" HOSE SUPPORT CLAMP, 3/8" BOLT
28	-	1AEMOLCP500	1/2" ID CONV WIRE LOOM
29	8	1AF009F0000	WASHER, FLT, 3/8", PLATED
30	23	1AFAP3809	1-1/4" HOSE SUPPORT CLAMP, 3/8" BOLT
31	1	1AKPAAC0000	HEX PLUG, 3/8", BRASS
32	2	1AFBP3362	U-BOLT, 3/8"-16 X 3W X 4L
33	2	1AFBP3584	BOLT, TERMINAL, HB646
34	1	1AFBP3587	1/4" NYLOCK NUT
35	56	1AFBP3612	NUT, HEX LOCK, 3/8-16, TOP LOCK
36	14	1AFBP3644	NUT, HEX LOCK, 5/16-18, TOP LOCK
37	1	1AFBP3648	BOLT, 1/4 X 1-1/4 GR.8
38	52	1AFBP3692	BOLT, FLNG HEAD, 3/8-16 X 1, GR.8, PLATED
39	12	1AFBP3709	BOLT, FLNG HEAD, 5/16-18 X 1, GR.8, PLATED
40	7	1AKAP3531	STRET TEE, 3/8", 90 DEGREES
41	3	1AKAP3532	STREET ELBOW, 3/8", 90 DEGREES
42	1	1AKAP4349	VALVE, CHECK, 3/8MP-3/8FP, HALDEX N-13526-AG
43	1	1AKAPAAE0000	PLUG, SQUARE HEAD, 3/4" NPT, BLACK
44	3	1AKTAACAAB0	TEE, RUN, 1/4 MP X 3/8 TUBE X 3/8 TUBE, BRASS
45	5	1ARAP4549	GROMMET, 1-3/8 OD X 1 ID X 3/8
46	1	1ASAP3557	VALVE, RELAY, HALDEX N-30096-PA
47	1	1ASH1000000	HVC, IMMDET RSPNSE-NO DUMP
48	2	1ASHP000000	VALVE, AIR PRESSURE PROTECTION W/ FILTER
49	2	3CAM9193	BRACKET, MOUNTING, LIFT AXLE CONTROL BOX
50	4	5CAM9018	BRACKET, AIR TANK MOUNTING
51	2	1AFBP3111	HEX CAP SCREW, 5/16-18 S 2-1/2, GR.5, PLATED

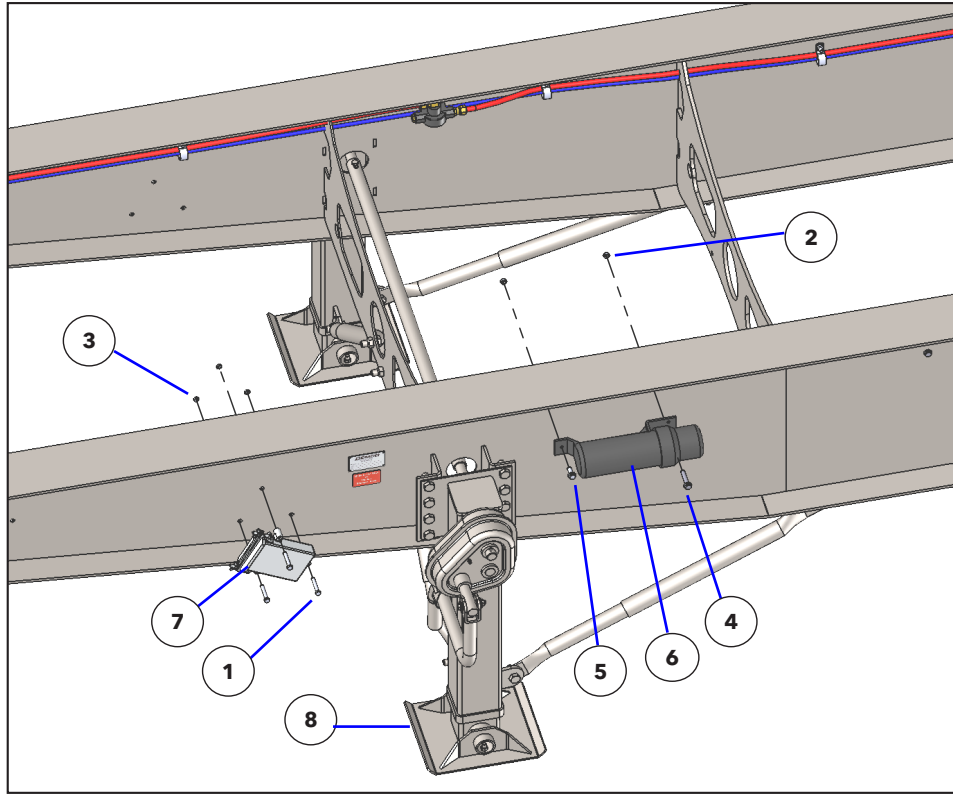

BOM ID	Qty	Item No	Description
1	3	1AFBP3601	HEX CAP SCREW, 5/16"-18 X 2", GR 5, PLTD
2	2	1AFBP3612	NUT, HEX LOCK, 3/8"-16, TOP LOCK, PLTD
3	3	1AFBP3644	NUT, HEX LOCK, 5/16"-18, TOP LOCK, PLTD
4	1	1AFBP3685	BOLT, FLANGE HEAD, 3/8"-16 X 2", GR 8, PLTD
5	1	1AFBP3692	BOLT, FLANGE HEAD, 3/8"-16 X 1", GR 8, PLTD
6	1	1AU0000011	MANUAL HOLDER, BLACK
7	1	1AUAP3811	JAMES KING DOCUMENT BOX, NO. 300
8	1	4CPKG00112	PACKAGE, LANDING GEAR, SIDE DUMP

Lights and Wiring

The lights and wiring system on every Demco Side Dump trailer meet or exceed all federal and state requirements in effect at the time of manufacture. Wherever required by law, lights and reflectors are marked by the manufacturer to indicate the appropriate specifications with which each complies.

For optimum performance and long life from the trailer's lights and wiring, follow this inspection procedure:

1. Clean all reflectors and lights. See that all lights burn properly. Replace all burned out lights and broken reflectors. Factory approved replacement parts should be used, and replacement bulbs of equal candle power should be used for safety.

⚠ WARNING! Use only a 12 volt DC battery for checking lights or anti-lock systems. Never use battery chargers or transformers.

2. Inspect all wiring to see that it is not frayed, and that it is properly supported and protected, with all connections tight. See that the light cable is clean and long enough to permit jackknife parking. Be certain that the cable is supported so that it cannot be pinched or entangled by the lower and upper couplers. Keep the 7-way plug on the light cable and the 7-way connector on the trailer free of corrosion.
3. Never replace fuses or breakers with metal foil or other devices.
4. A decal is located near the 7-way connector. You may trace individual electrical circuits by the wire colors indicated. Refer to the schematic drawing and the decal for conductor number and wire colors.

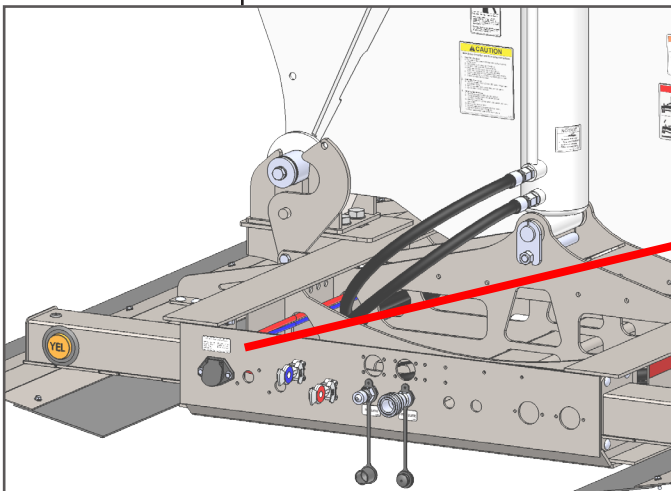

Wiring Harness Color Code	
WHITE - Ground	YELLOW - Lt Turn
BLACK - Marker	GREEN - Rt Turn
RED - Stop	BLUE - Auxiliary
BROWN - Tail	

AP 3674

1AQAP3674
WIRING HARNESS COLOR CODE DECAL

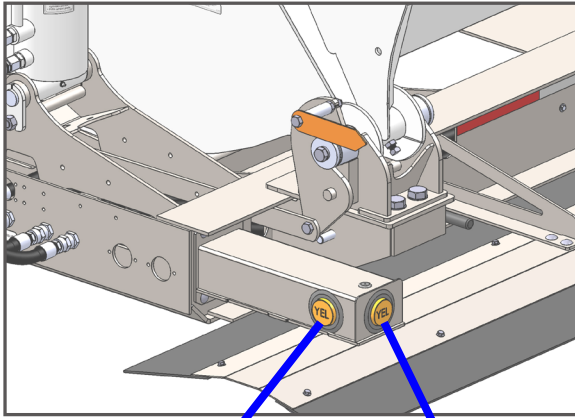

4 5 4 5

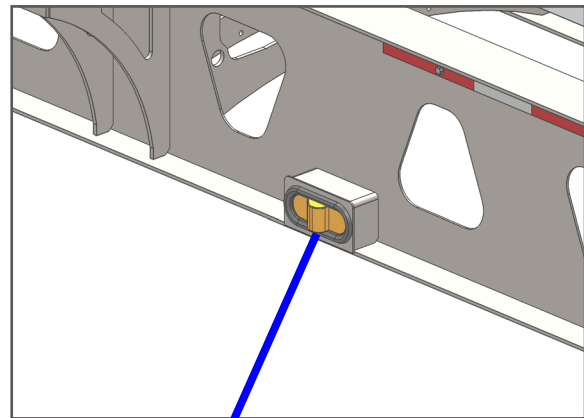

8 9 3 5

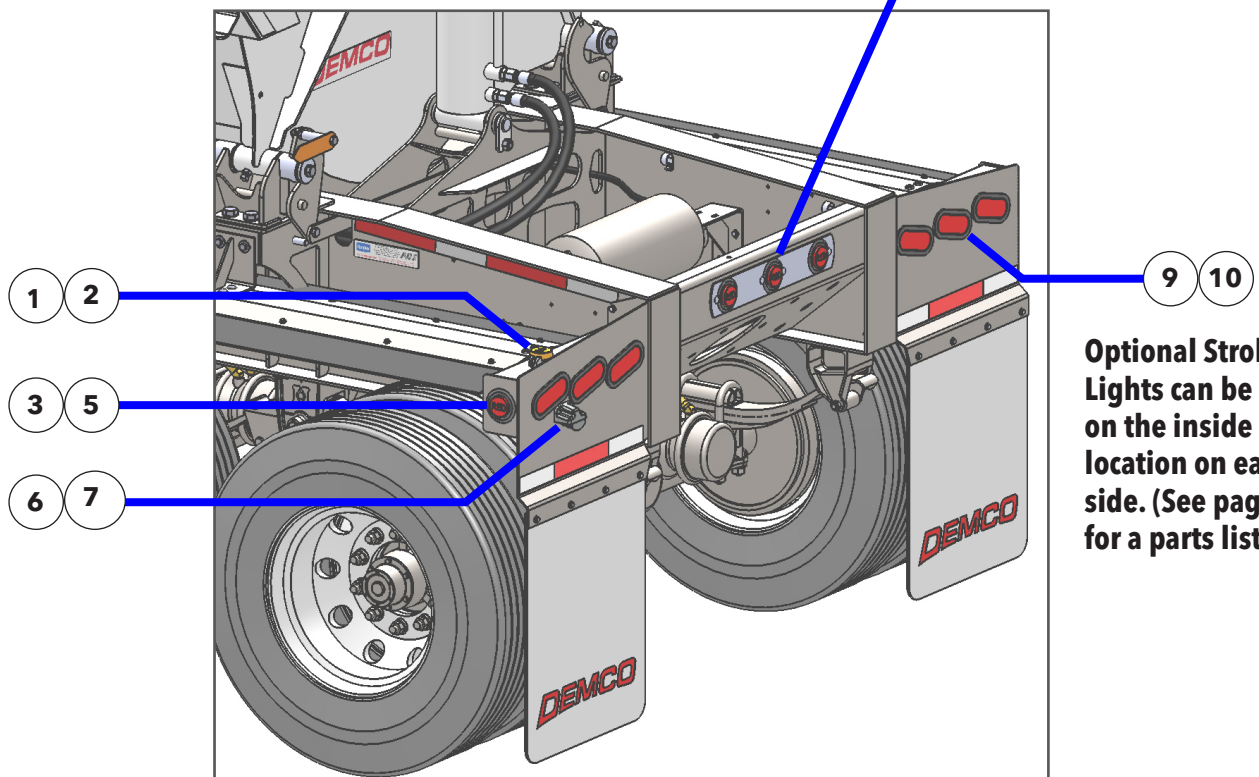

Optional Strobe Lights can be added on the inside light location on each side. (See page 82 for a parts list.)

BOM ID	Qty	Item No	Description
1	1	1AEAP4301	ABS LIGHT BRACKET
2	1	1AEAP4302	ABS LIGHT
3	5	1AEAP4310	LAMP, LED, M/C, RED, 2-1/2"
4	4	1AEAP4311	LAMP, LED, M/C, YELLOW, 2-1/2"
5	9	1AEG0010700	2-1/2" ROUND GROMMET ONLY
6	1	1AEL0015208	LICENSE LAMP
7	1	1AEL0015730	BRACKET-BLACK
8	2	1AEL060215Y	MIDSHIP TURN LAMP
9	8	1AEL0607003	6" OVAL LIGHT GROMMET
10	6	1AEL6050000	LAMP, LED, S/T/T, RED, 6" OVAL

BOM ID	Qty	Item No	Description
11	2	1AEP0094972	HARNESS, M/C PLUG, WITH M-BULLETS
12	1	1AEX0088300	HARNESS, ID 3 PLUG, LOWER, 60"
13	1	1AEX0088911	HARNESS, REAR S/T/T, RH & LH
14	2	1AEX0094932	HARNESS, 2-PLUG Y-ADAPTER
15	1	1AEX3030024	HARNESS, LICENSE LAMP, 24"
16	2	1AEX3270084	HARNESS, FRONT M/C, 84"
17	1	1AEX3550096	HARNESS, LH MIDSHIP LIGHT, 96"
18	1	1AEX3560048	HARNESS, RH MIDSHIP LIGHT, 48"
19	1	1AEX5220312	HARNESS, ABS JUMPER, 312"
20	1	1AEX8502027	HARNESS, FRONT NOSE W/ BL-WHT DROPOUT
21	1	1AEX8810240	HARNESS, ABS POWER, 240"
22	1	1AEX9751552	HARNESS, 7 COND MAIN W/BRKOUT, 552"

Note: Images of some of these parts are continued on the next page.

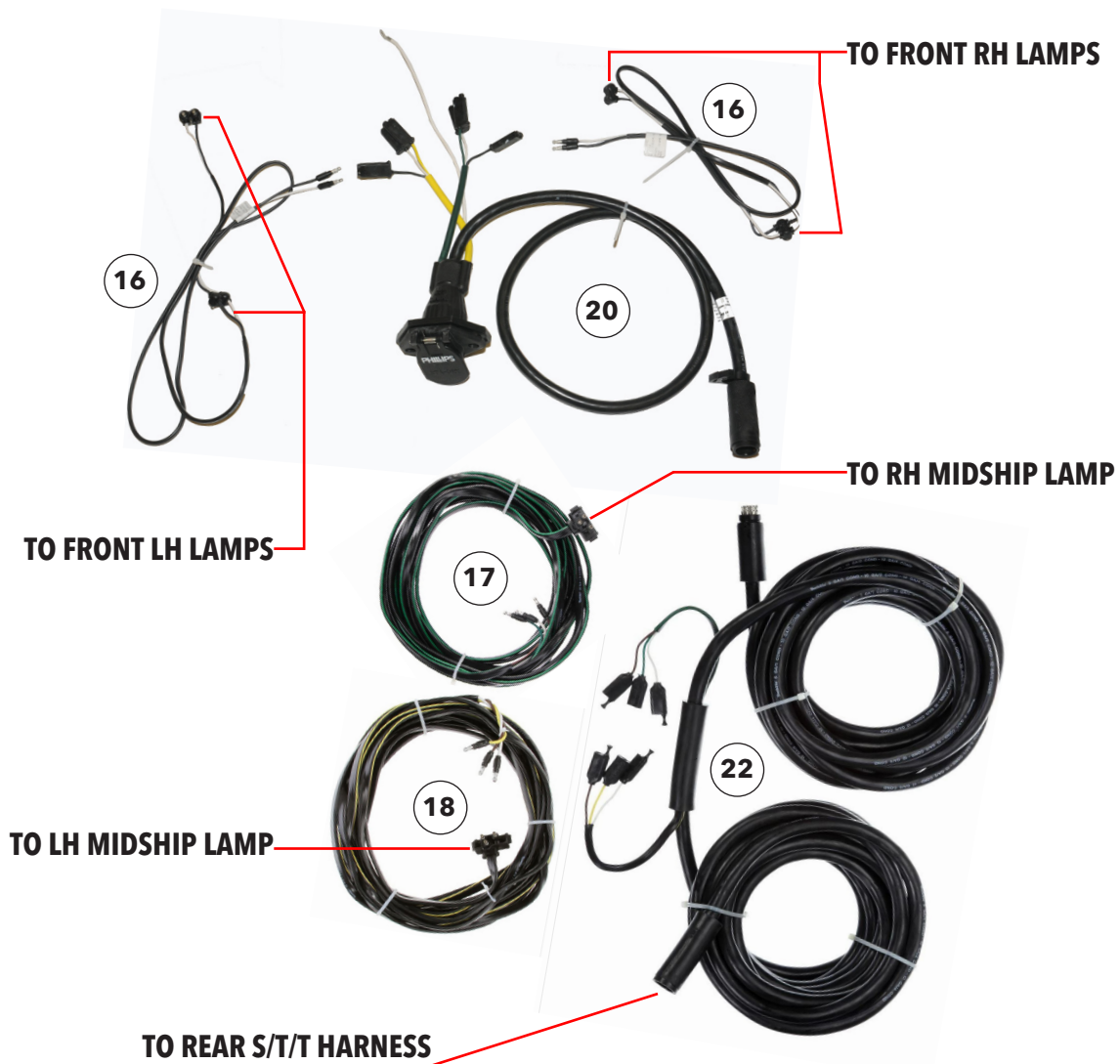

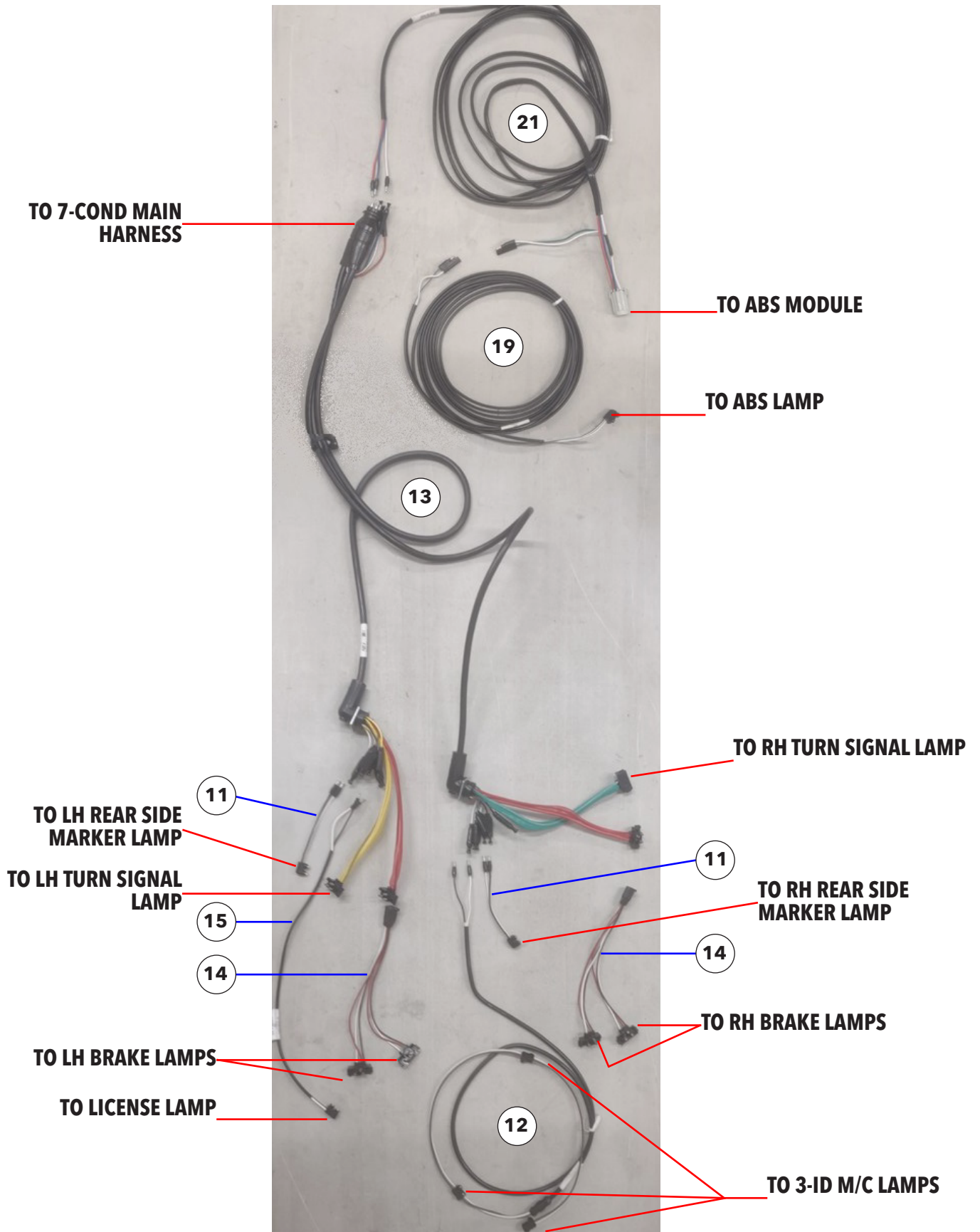

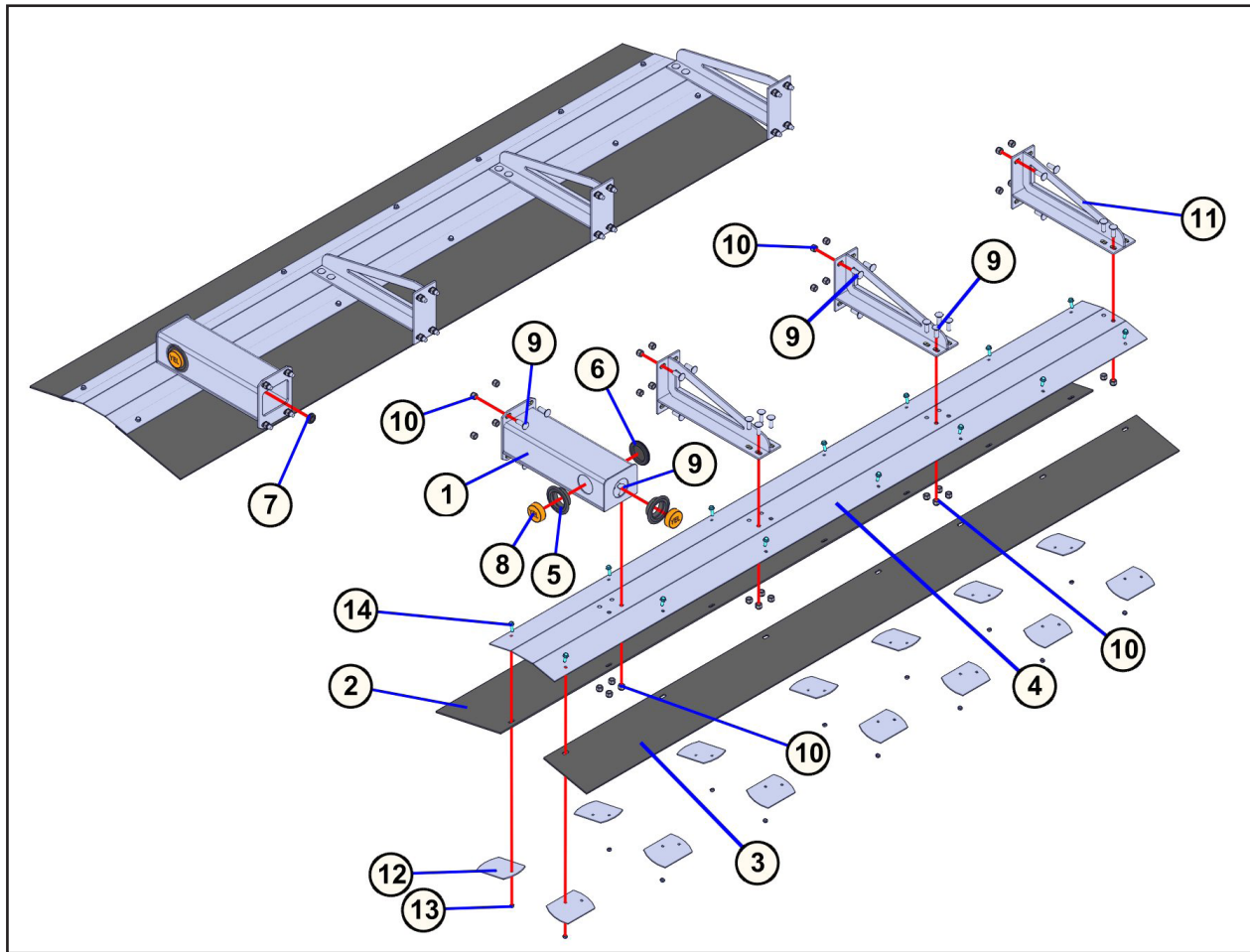

BOM ID	Qty	Item No	Description
1	2	5CAM9005	FRONT LIGHT/FENDER MOUNT
2	2	3CAM9091	FENDER RUBBER, 12" X 108", FRONT
3	2	3CAM9092	FENDER RUBBER, 8" X 108", FRONT
4	2	3CAM9386	FENDER SUPPORT, FRONT, 2013
5	4	1AEP3548	LAMP, SUPER 10 GROMMET, 10700-3
6	2	1ARAP4010	GROMMET, PLUG, 2-3/4" HOLE, G8077-046000
7	2	1ARAP4045	GROMMET, 3/4" ID G3137-016
8	4	1AEP4311	LAMP, LED, CLEAR/MARKER, YELLOW, 2-1/2"
9	60	1AFBP3232	BOLT, CARRIAGE, 1/2"-13 X 1-1/2", GRADE 5
10	60	1AFBP3704	NUT, LOCK, NYLON INSERT, 1/2"-13
11	6	5CAM9004	FRAME FENDER MOUNT
12	28	3CAM9089	FENDER WASHER
13	28	1AFBP3644	NUT, HEX LOCK, 5/16"-18, TOP LOCK
14	28	1AFBP3709	BOLT, FLANGE HEAD, 5/16"-18 X 1", GRADE 8, PLATED

BOM ID	Qty	Item No	Description
1	5	1AEAP3548	LAMP, SUPER 10 GROMMET, 10700-3
2	1	1AEAP4120	LISCENSE PLATE LAMP, CLEAR, 12V
3	1	1AEAP4121	LISCENSE PLATE LAMP MTG BRACKET, GREY
4	1	1AEAP4301	ABS LIGHT BRACKET, 102008HP
5	1	1AEAP4302	ABS LIGHT, 101731F
6	5	1AEAP4310	LAMP, LED, CLEAR/MARKER, RED, 2-1/2"
7	6	1AEL0607003	MIDSHIP LIGHT GROMMET
8	6	1AEL6050000	RED 6" OVAL-LED
9	2	1AF009D0000	WASHER, FLAT, 1/4", PLTD
10	4	1AF009F0000	WASHER, FLAT, 3/8", PLTD
11	4	1AF009H0000	WASHER, FLAT, 1/2", PLTD
12	2	1AFBP3587	1/4" NYLOCK NUT
13	2	1AFBP3600	HEX CAP SCREW, 1/4-20 X 1 GRD 8, PLTD
14	30	1AFBP3612	NUT, HEX LOCK, 3/8-16, TOP LOCK
15	2	1AFBP3642	PAN HEAD MACHINE SCREW, #10-24 X 3/4"
16	2	1AFBP3643	WASHER, #10 USS FLAT Z
17	4	1AFBP3687	BOLT, CARRIAGE, 3/8-16 X 4, GRD 5, PLTD
18	18	1AFBP3692	BOLT, FLNG HEAD, 3/8-16 X 1, GRD 8, PLTD
19	4	1AFC12FAA05	HEX CAP SCREW, 3/8"-16 X 1", GRD 5, PLTD
20	4	1AFC12HAAH0	HEX CAP SCREW, 1/2"-13 X 1-1/2", GRD 5, PLTD
21	2	1AFC18C0000	NYLON INSERT LOCKNUT, 10-24 UNC, ZINC
22	4	1AFC18H0000	1/2" NYLOCK NUT
23	4.16'	1AQAS000000	RWR CONSPICUITY TAPE
24*	1	1AU00000804	MUDFLAP, DEMCO, 24" X 30"
25	1	3CAM9008	BACK COVER, ID LIGHTS
26	2	3CAM9010	BRACKET, FENDER MOUNT
27	2	3CAM9011	SPACER TUBE
28	2	3CAM9035	MUDFLAP BACKING STRAP
29	1	3CAM9058	ID LIGHT FACE PLATE
30	1	5C000181	FENDER / MUDFLAP MOUNT, LH, (DRIVER'S SIDE)
31	1	5C000182	FENDER / MUDFLAP MOUNT, RH, (PASSENGER SIDE)

*Shown with optional Demco Mudflap.

FENDER PARTS -- REAR

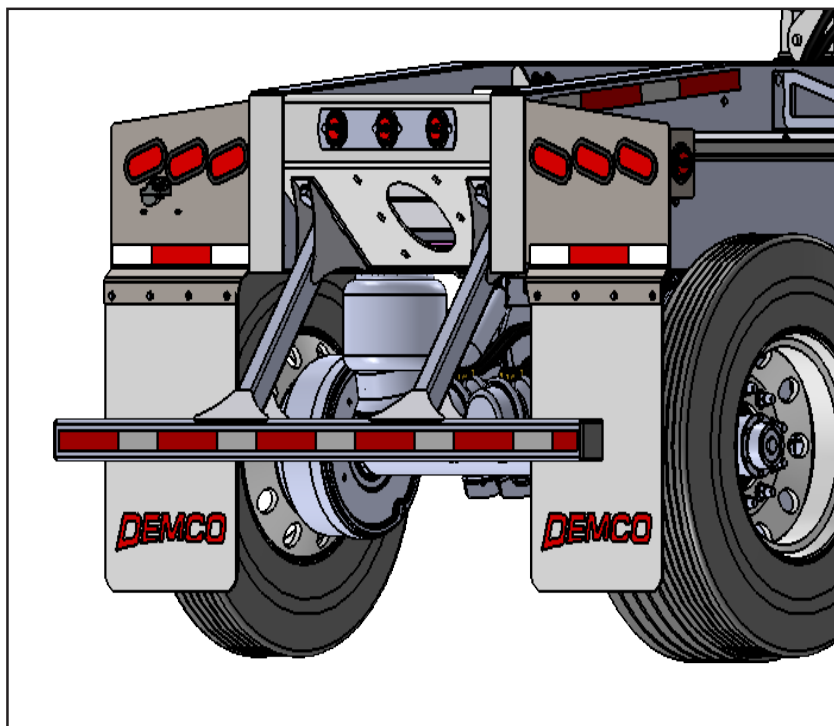
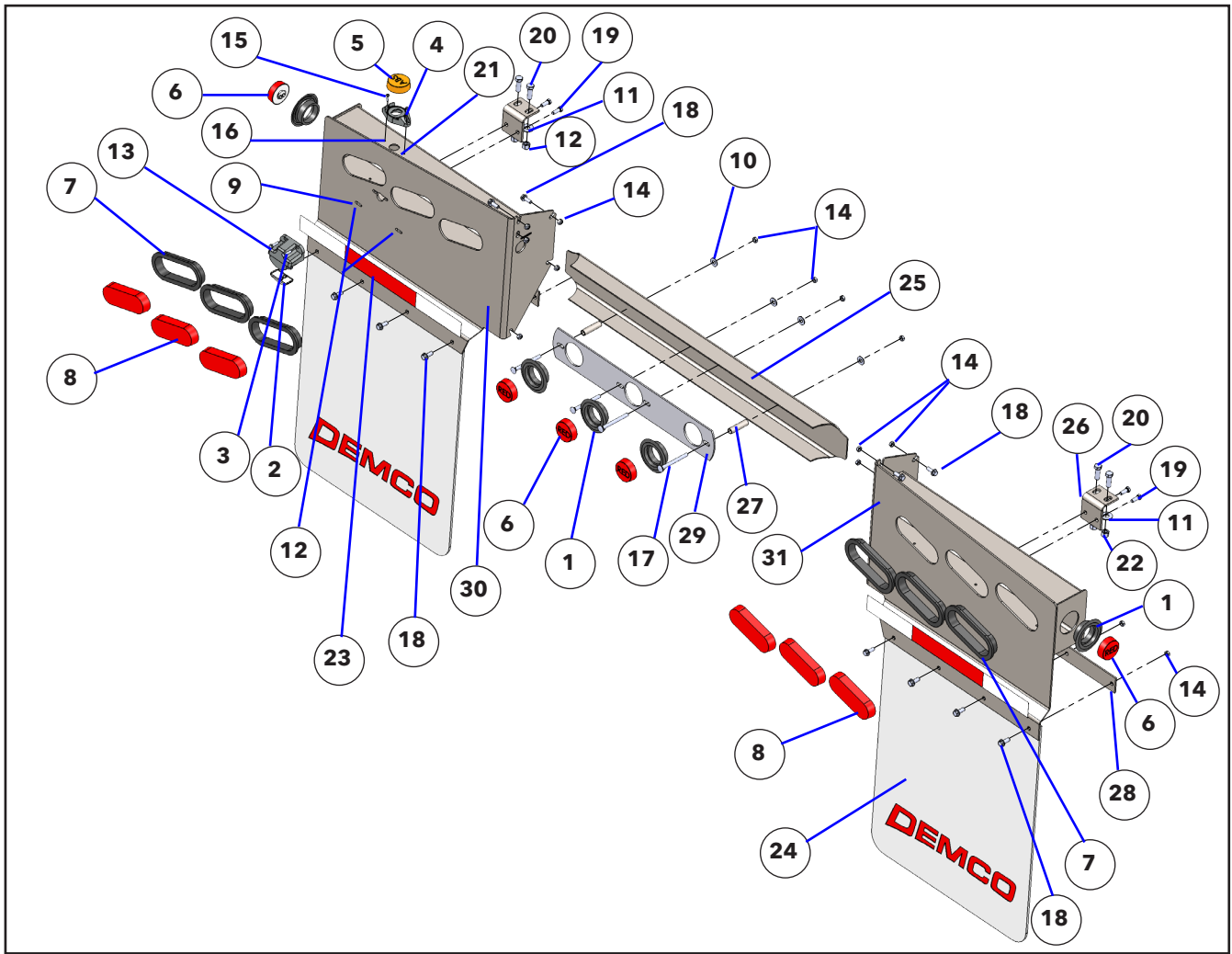

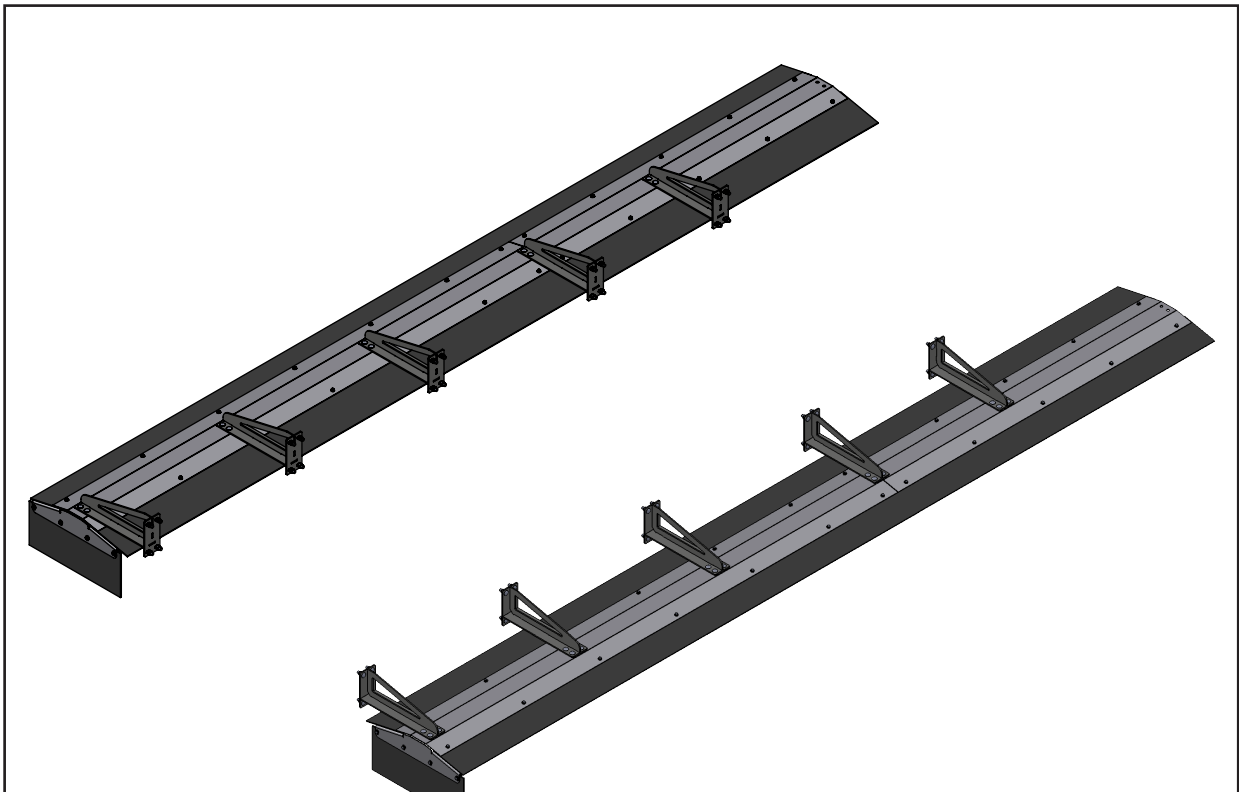
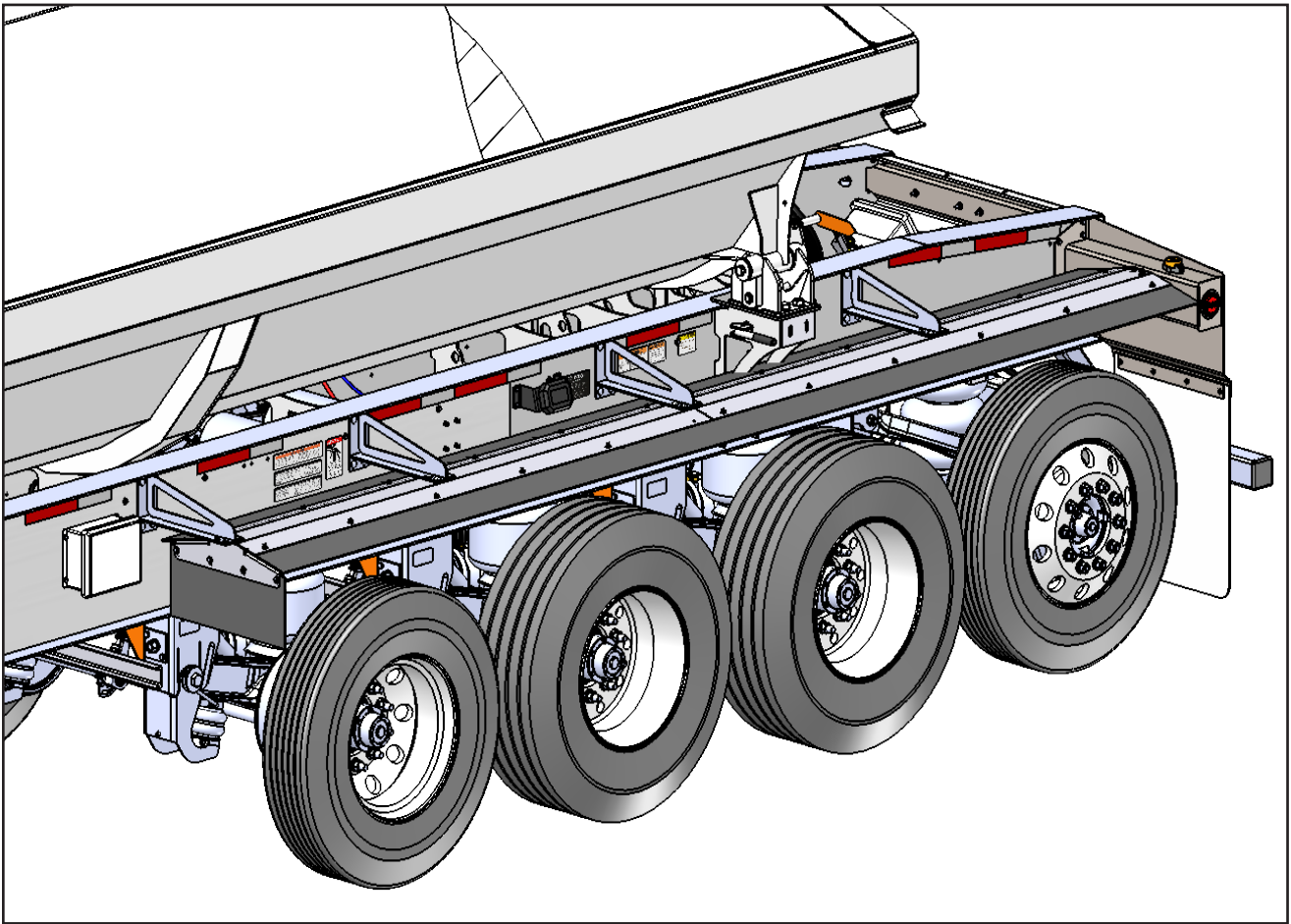

FENDER PARTS -- REAR (For 47' CBX Air Ride Quad-Axle With 37' Tub)

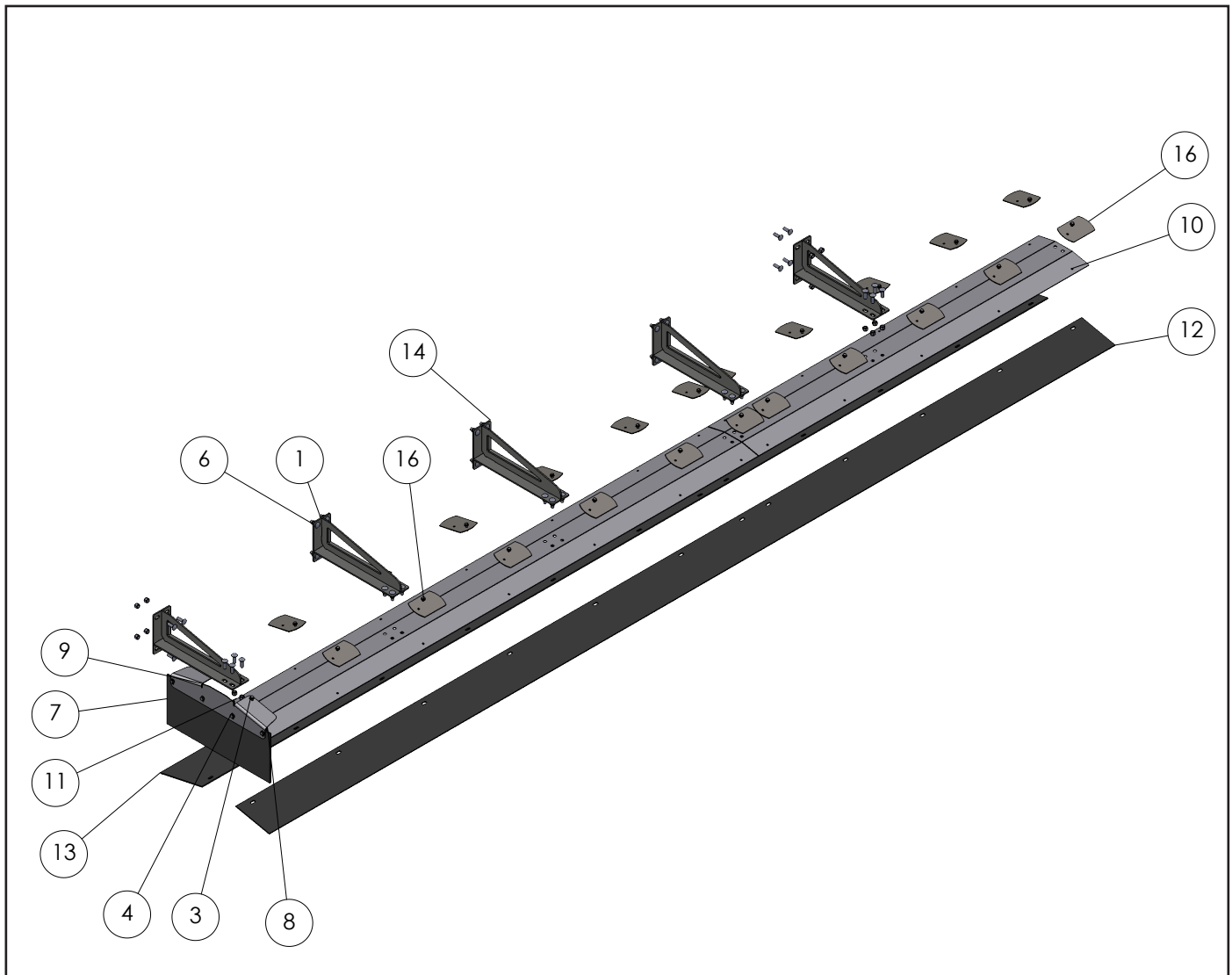

BOM ID	Qty	Item No	Description
1	40	1AFBP3232	BOLT, CARRIAGE, 1/2-13 X 1-1/2, GR.5
2	4	1AFBP3612	NUT, HEX LOCK, 3/8-16, TOP LOCK
3	24	1AFBP3644	NUT, HEX LOCK, 5/16-18, TOP LOCK
4	4	1AFBP3692	BOLT, FLANGE HEAD, 3/8-16 X 1, GR.8, PLATED
5	24	1AFBP3709	BOLT, FLANGE HEAD, 5/16-18 X 1, GR.8, PLATED
6	40	1AFC18H0000	NYLON INSERT LOCKNUT, 1/2-13 UNC
7	1	1AUAP4027	MUD FLAP, BLACK, RUBBER
8	1	3CAM9035	MUD FLAP BACKING STRAP
9	22	3CAM9089	FENDER WASHER
10	1	3CAM9411	MUD FLAP MOUNT, FENDER
11	1	3CAM9449-1	FENDER SUPPORT, REAR, SPREAD, 77-1/8"
12	1	3CAM9455-1	FENDER SUPPORT, REAR, QUAD, 120-1/4"
13	1	3CAM9456	FENDER RUBBER, REAR, 8", QUAD, 34' TUB, 197-1/2"
14	1	3CAM9457	FENDER RUBBER, REAR, 12", QUAD, 34' TUB, 197-1/2"
15	5	5CAM9004	FRAME FENDER MOUNT

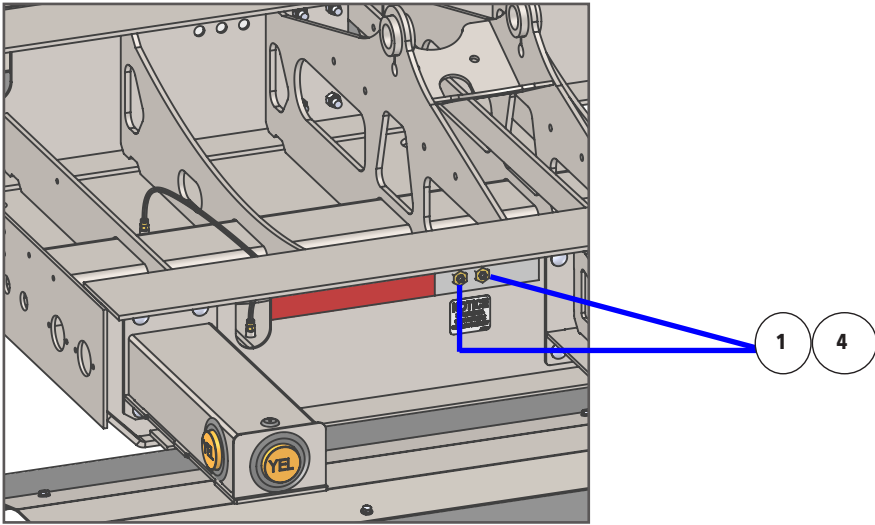
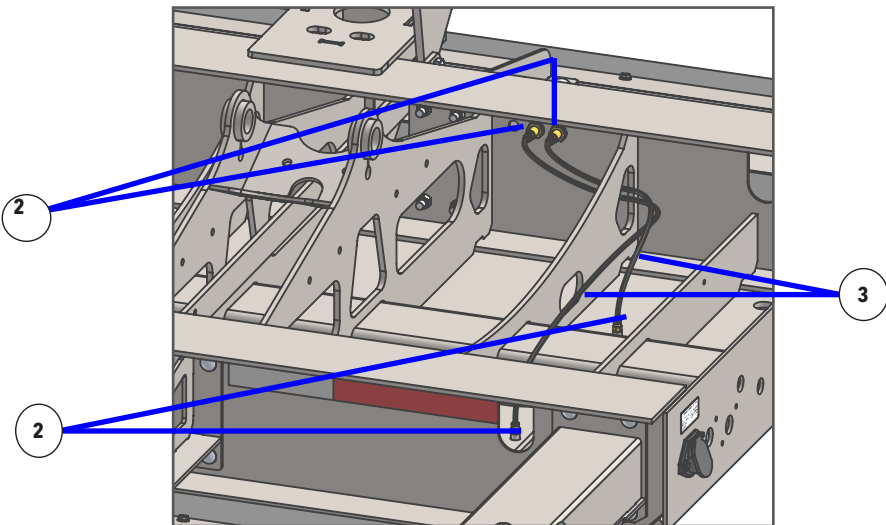

BOM ID	Qty	Item No	Description
1	2	1ABAP3423	BULKHEAD ADAPTER, 1/8 FPT - 1/8 FPT
2	4	1ABAP3426	ADAPTER, 1/4" TUBE X 1/8 MPT, STRAIGHT
3	4.63'	1ABAP3685	NYLON TUBING, BLACK, 1/4"
4	2	1AKZAAA0000	GREASE ZERK, 1/8" NPT

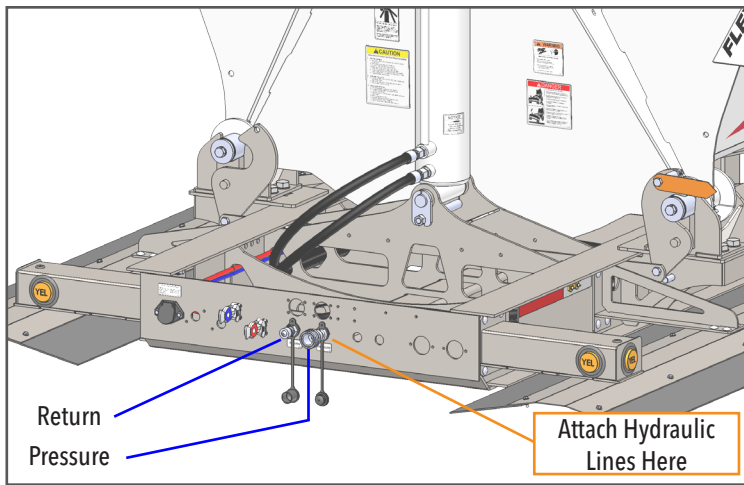

WARNING: Hydraulic fluid escaping under pressure can have enough force to penetrate the skin. Hydraulic fluid may also infect a minor cut or opening in the skin. If injured by escaping fluid, see doctor at once. Serious infection or reaction can result if medical treatment is not given immediately. Make sure all connections are tight and that hoses and lines are in good condition before applying pressure to the system. Relieve all pressure before disconnecting the lines or performing other work on the hydraulic systems.

Truck-Tractor Hydraulic Systems

Efficient, safe operation of side dump trailers require that the tractor hydraulic system provide a clean, high pressure, high volume oil supply. The hydraulic pump pressure should be set at 2500 PSI with a minimum output of 25 GPM supply and a minimum 15 gallon filtered and strained reservoir.

NOTE:

Hydraulic Oil Filter should be Changed every 25,000 miles or yearly, which ever comes first and hydraulic system flushed every 50,000 miles with pressure and flow rates checked.

Generic Tractor Hydraulic System

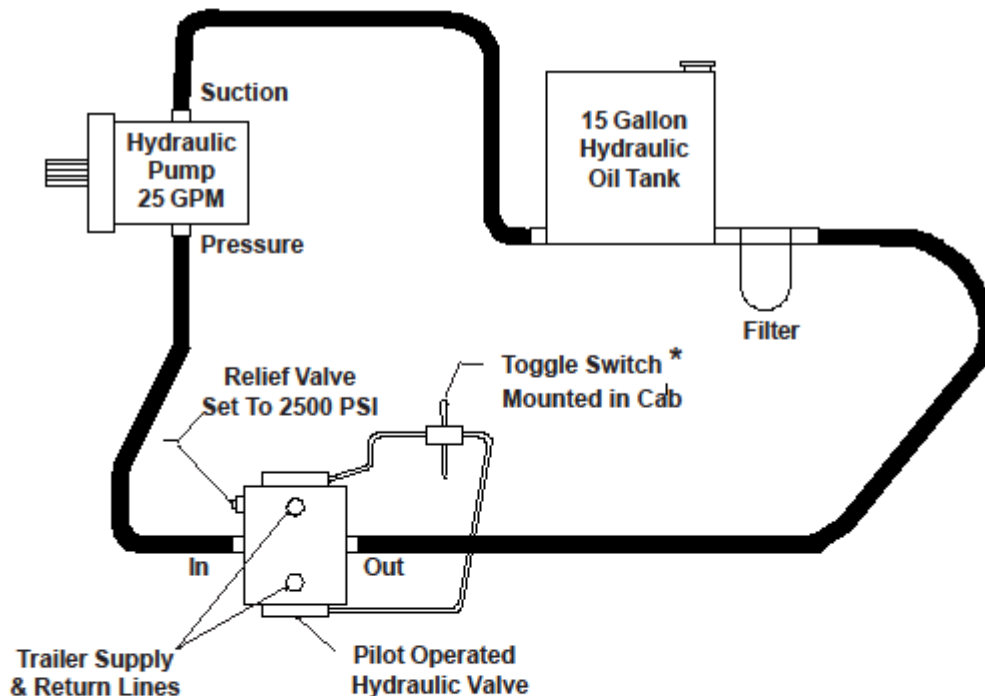

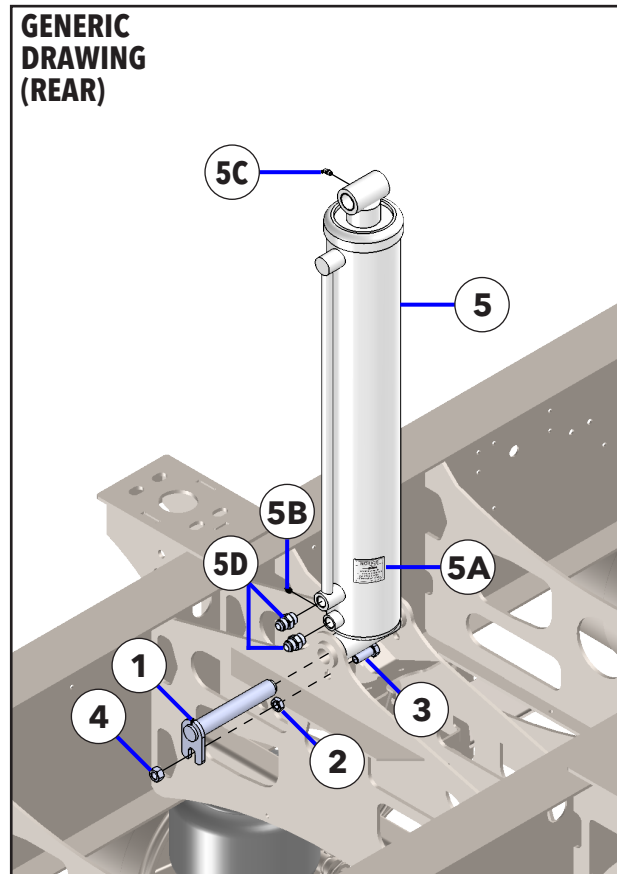
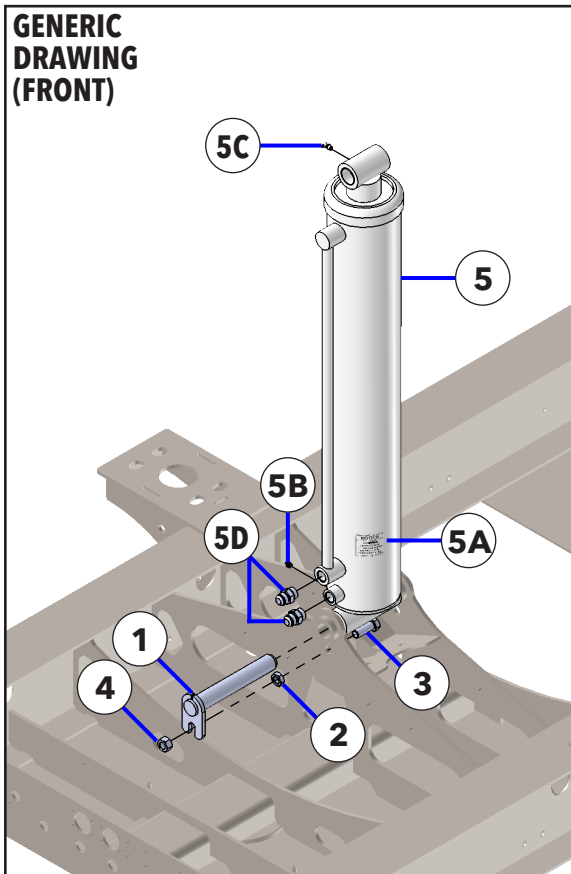

BOM ID	Qty	Item No	Description
1	2	5CAM9019	PIN, CYLINDER, 1-1/2" X 9-5/8"
2	2	1AFBP3107	NUT, HEX JAM, 3/4"-10, GR 2, PLATED
3	2	1AFBP3139	HEX CAP SCREW, 3/4"-10 X 2", GR 5, PLATED
4	2	1AFC05L0005	3/4 CENTERLOCK NUT
5	2	1AYDP6347	CYLINDER, HYDRAULIC, 5" X 36", WITH DROP TUBE
5	2	1AYDP6349	CYLINDER, HYDRAULIC, 6" X 36", WITH DROP TUBE
5A	2	1AQAP2986	DECAL, GREASE TRAILER WEEKLY, 2-3/4"W X 3"T
5B	2	1AKZAAA0000	GREASE ZERK, 1/8" NPT
5C	2	1AFBP3654	GREASE ZERK, 1/8" MP X 45 DEGREE ELBOW
5D	4	1AKDP4368	ADAPTER, 12MJIC-12MSAE, STRAIGHT, 6400-12
*	1	1AKDP6603	SEAL KIT 5" WETHERELL CYLINDER
*	1	1AKDP6569	SEAL KIT 6" WETHERELL CYLINDER

*Not shown in part diagrams.

(5C090053) HYDRAULICS PKG, STANDARD SET FORWARD, 37' TUB

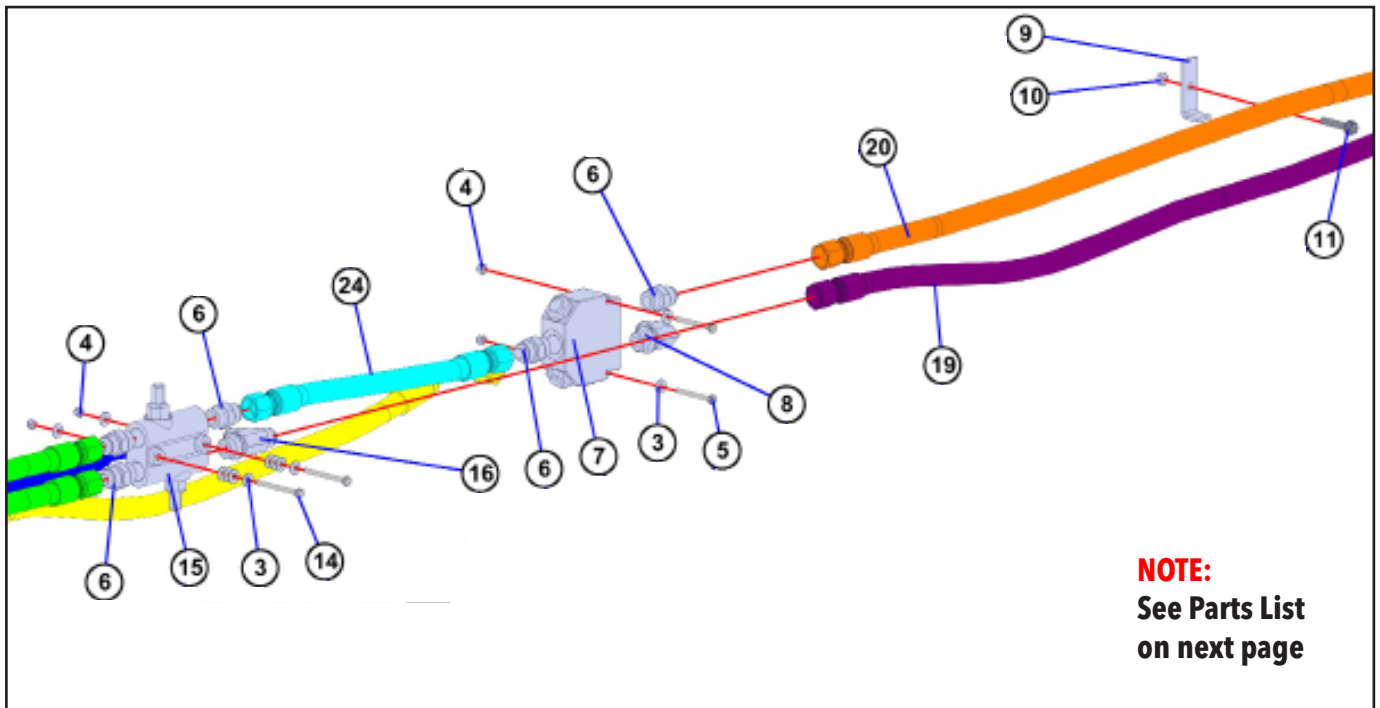
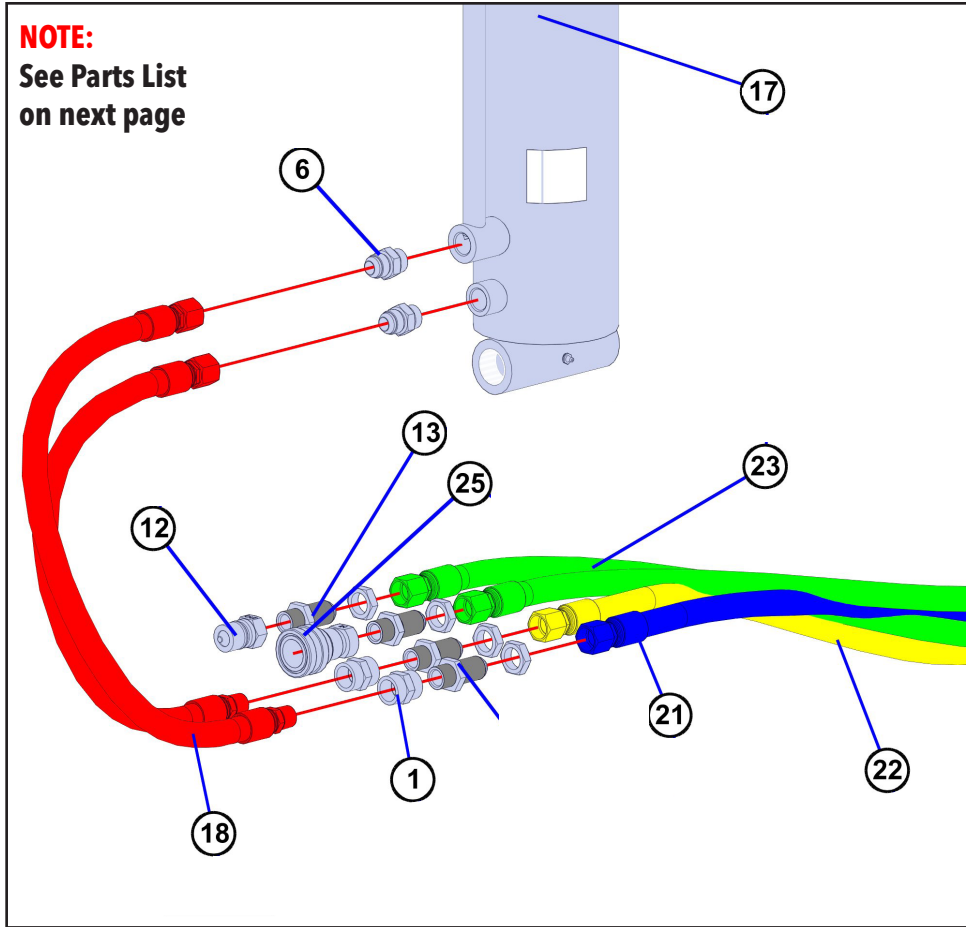

(5C0900053) HYDRAULICS PKG, STANDARD SET FORWARD, 37' TUB

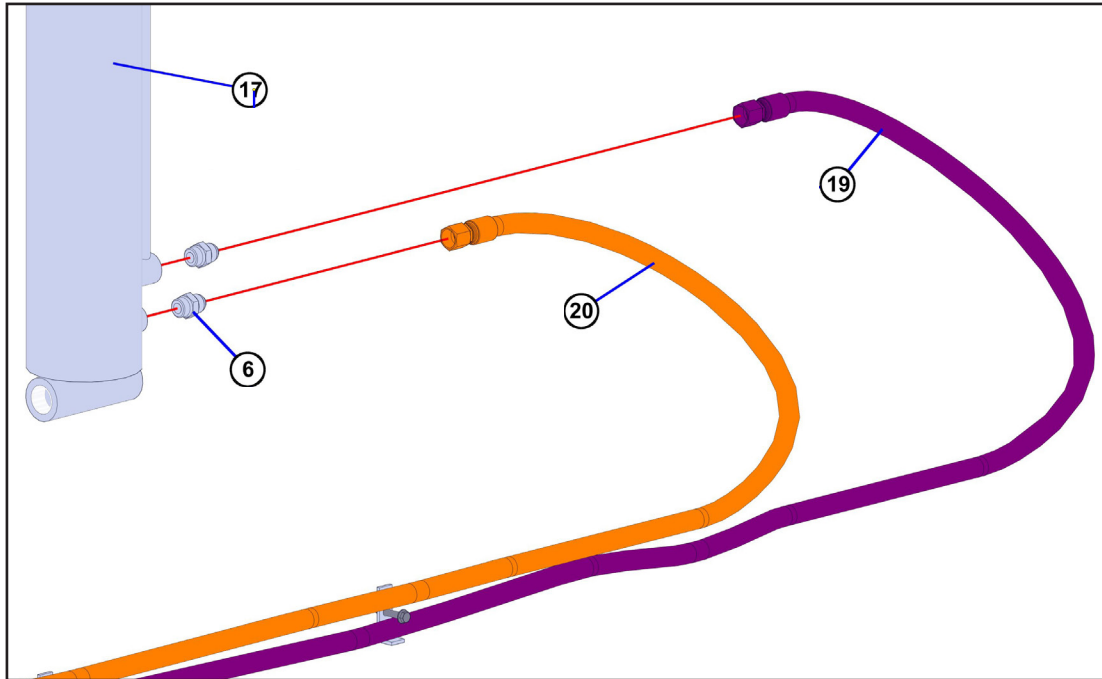

BOM ID	Qty	Item No	Description
1	2	1ACDP6307	COUPLING, 12FP-12FP, 5000-12
2	4	1AKDP6495	BULKHEAD ADAPTER WITH NUT, 12MP-12MJ, 2706-LN-12-12
3	12	1AF009D0000	1/4" FLAT WASHER INC
4	4	1AFBP3587	NUT, HEX LOCK, 1/4"-20
5	2	1AFBP3589	HEX CAP SCREW, 1/4"-20 x 2-1/2" GRADE 8, PLTD
6	7	1AKDP4368	ADAPTER, 12MJIC-12MSAE, STRAIGHT, 6400-12
7	1	1AKDP6303	VALVE, PROPORTIONAL DIVIDER, PRINCE
8	1	1AKDP6538	ADAPTER, 12MJ-12MSAE 90, 6801-12
9	14	3CAM8053	HOSE RETAINER, SINGLE
10	14	1AFBP3612	NUT, HEX LOCK, 3/8"-16, ZINC TOP LOCK GRC ZINC & WAXED
11	14	1AFBP3685	BOLT, FLNG HHEAD, 3/8"-16 X 2, GRADE 8, Y-ZINC PLATED
12	1	1ACDP6301	COUPLER, QUICK, MALE, 3/4" NPT
13	4	1AKDP6495	BULKHEAD ADAPTER WITH NUT, 12MP-12MJ, 2706-LN-12-12
14	2	1AFBP3588	HEX CAP SCREW, 1/4"-20 X 3", GRADE 8, PLATED
15	1	1AKDP6302	VALVE, DOUBLE RELIEF, PRINCE, H-L
16	1	1AKDP6557	TEE, 12MJ-12MSAE-12MJ, 6804-12
17	2	1AYDP6349	CYLINDER, HYDRAULIC, 6" X 36", WITH DROP TUBE
18*	2	1AKDP6526	HOSE, HYDRAULIC, 3/4" X 40", 12FJX-12MP
19*	1	1AKDP6527	HOSE, HYDRAULIC, 3/4" X 460", 12FJX-12FJX
20*	1	1AKDP6528	HOSE, HYDRAULIC, 3/4" X 435", 12FJX-12FJX
21*	1	1AKDP6534	HOSE, HYDRAULIC, 3/4" X 62", 12FJX90-12FJX
22*	1	1AKDP6535	HOSE, HYDRAULIC, 3/4" X 87", 12FJX90-12FJX
23*	2	1AKDP6547	HOSE, HYDRAULIC, 3/4" X 68", 12FJX-12FJX
24*	1	1AKDP6558	HOSE, HYD, 3/4" X 18-1/2", 12FJX-12FJX
25	1	1ACDP6300	COUPLER, QUICK, FEMALE, 3/4" NPT

*These are parts make up (1AKDDP1190) HOSE KIT, 37' TUB, SET FORWARD

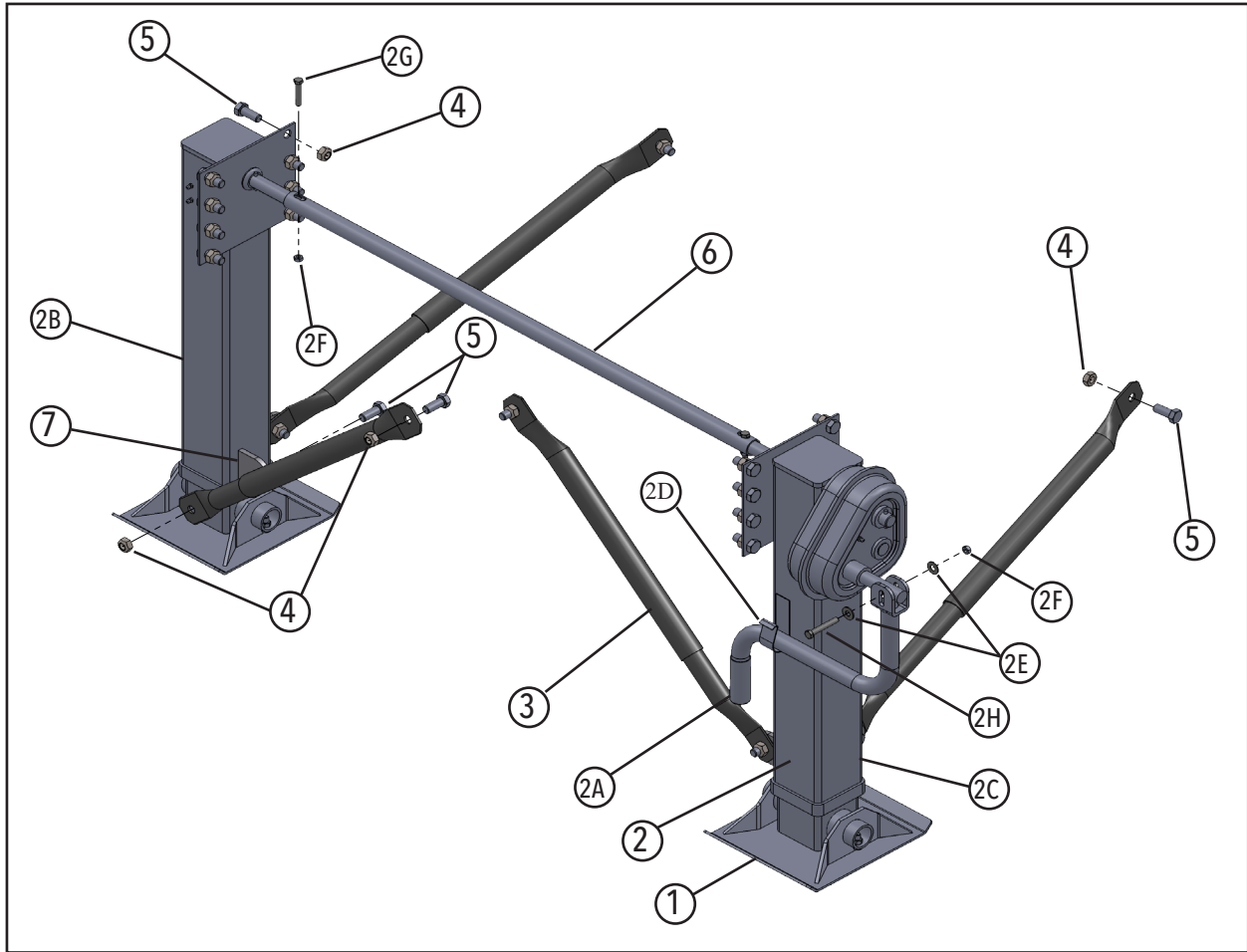

BOM ID	Qty	Item No	Description
1	1	4CPKG00112	PACKAGE, JACK, 2001 SIDE DUMP
2	1	1AJAP3503	JACK, LANDING LEG AND GEAR SET
2A	1	1AJAP3504	CRANK HANDLE
2B	1	1AJAP4098	JACK LEG, CURB SIDE
2C	1	1AJAP4099	JACK LEG, ROAD SIDE
2D	1	1AJAP4101	CRANK HANDLE CLIP
2E	2	1AFBP3015	WASHER, FLAT, 3/8", PLATED
2F	3	1AFBP3612	NUT, HEX LOCK, 3/8"-16, TOP LOCK
2G	2	1AFBP3625	HEX CAP SCREW, 3/8"-16 X 2", GRADE 8, PLATED
2H	1	1AFBP3626	HEX CAP SCREW, 3/8"-16 X 2-1/2", GRADE 8, PLATED
3	4	1ASAP3505	ADJUSTABLE BRACE
4	24	1AFBP3615	NUT, HEX LOCK, 5/8"-11, GRADE 8, PLATED, UTC
5	24	1AFBP3617	HEX CAP SCREW, 5/8"-11 X 1-1/2", GRADE 8, PLATED
6	1	1AU00000146	CROSS SHAFT, SHORT
7	4	3C000371	JACK BRACE MOUNT TAB



SAF-HOLLAND Group

ATLAS 55 Standard - Exploded View

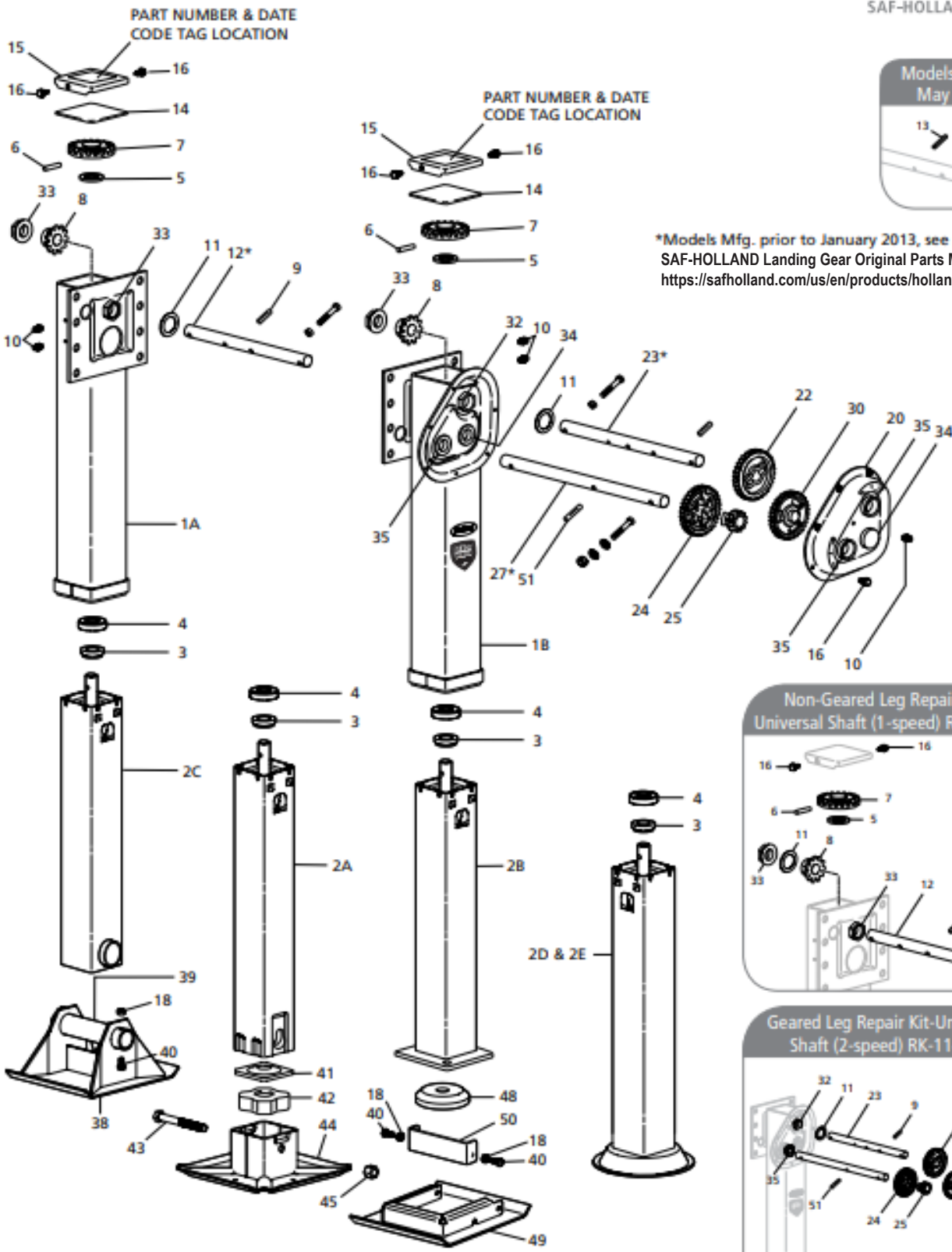

*Models Mfg. prior to January 2013, see page 1-19.
SAF-HOLLAND Landing Gear Original Parts Manual
<https://safholland.com/us/en/products/holland-atlas-55>

Non-Geared Leg Repair Kit-
Universal Shaft (1-speed) RK-11442

Geared Leg Repair Kit-Universal
Shaft (2-speed) RK-11443

For a complete parts list or technical assistance, please go to www.safholland.us or call 800.876.3929

LANDING GEAR -- SAF-HOLLAND

Parts List for Atlas 55 Standard and NoLube Landing Gear

NO.	DESCRIPTION	RETRACT TUBE CODE	17" TRAVEL STANDARD	17" TRAVEL NOLUBE
2A	Retract Tube - RCF	0 or 5 (MRL)	LG3053-04	LG3071-04
2B	Retract Tube - Low Profe RCF	0	LG3097-03	LG3097-13
2C	Retract Tube - Axle	0	LG3012-03	LG3077-03
2D	Retract Tube - Shockfoot 10" DIA	0, 6 (CAN) or B	LG3061-04	LG3095-01
2E	Retract Tube - Shockfoot 12" DIA	0, 6 (CAN) or B	LG3061-05	LG3095-02

NO.	DESCRIPTION	PART NO.	SPEED ONE	SPEED TWO
1A	Upper Housing LH	N/A	-	-
1B	Upper Housing RH	N/A	-	-
3	Collar	XB-LG0544	1	1
4	Thrust Bearing	XB-BRG-013-77	1	1
5	Washer - FL 2" OD x 1.19" ID x .13" THK	XB-PW-016-62	1	1
6	Pin - DIA .39" x 2"	XA-CRP-V-06635	1	2
7	Bevel Gear	LG2884	1	1
8	Pinion Gear	LG1823-02	1	1
9	Groove Pin - DIA .38" x 1.50"	XB-GP-014-18	1	1
10	Ftg - Grease .25" -28 Self-Tapping	XB-GRF-022-16	2	3
11	O-Ring, #319	2024100000100	1	1
12	Jack Shaft LH Universal Mount	LG2964-01	1	-
13	Pin - Spring DIA .25" x 1.5" (Not Required)	N/A	-	-
15	Top Cover	2111100004080	1	1
16	Self-Tapping Screw .25" -20 x .5" Lg	XB-STS-008-11	2	9
17	Screw, Hex Cap .38"-16 x 2.25" Lg GR5	XB-HHC-050-42	1	2
18	Self-Locking Nut .38"-16 - Sandshoe	XB-SLN-012-04	2	3
19	Washer .38" Std Type A	XB-PW-016-03	--	2
20	Gearbox Half, Outside w/Hole for Grease Fitting	LG2996	-	1
22	Output Gear	LG2980	-	1
23	Jackshaft RH - Universal Mount	LG2963-01	-	1
24	Gear, Drive, High Speed - Machined	2040100000060	-	1
25	Gear, Drive, Low Speed - Machined	2040100000050	-	1
26	Groove Pin, Type E DIA .38" x 2.00" Lg	XB-GP-052-21	-	1
27	Shift Shaft - Universal	2111100003400	-	1
30	Idler Gear	LG2975	-	1
32	Boss, Hex Lock - Oversized	2022100000180	-	1
33	Hex Lock Boss - Sealed	LG2926-10	2	1
34	Idler Shaft Bushing (Included in Item #23)	LG3005	-	2
35	Boss Bearing - Sealed (Included in Item #20)	LG0659-10	-	3
38	Sandshoe - 10" x 12" x 2.00"	50616007	1	1
39	Sandshoe Axle - Hollow Axle 8.50" Lg	LG0070-02	1	1
40	Screw, Hex Cap .38"-16 x .75" Lg GR5 - Sandshoe	XB-HHC-050-69	1	1
	Screw, Hex Cap .38"-16 x .75" Lg GR5 - Low Profile RCF	XB-HHC-050-69	2	2
41	Foot Plate	LG0725	1	1
42	Foot Rubber	XB-LG0726	1	1
45	Self-Locking Nut - .63-11"	XB-SP0012-10	1	1
48	Foot Pad - Low Profile RCF	728003	1	1
49	Interchangeable Collar - Low Profile RCF	730640	1	1
50	Interchangeable Strap	730638	1	1
51	Pin Groove, .31" Dia x 2.00" Lg	XB-GP-052-52	-	1

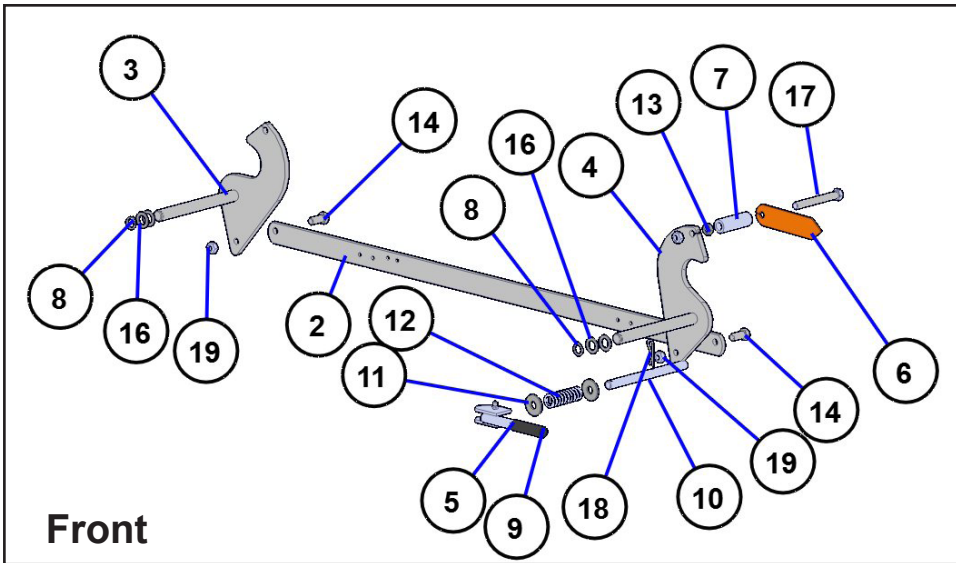

Front

BOM ID	Qty	Item No	Description
1	1	4CPKG00113	PACKAGE, PIVOT LATCH, 2001 SIDE DUMP
2	2	3CAM9078	LATCH CONNECTOR
3	2	5CAM9123	TUB PIVOT LOCK, LEFT HAND FRONT/RIGHT HAND REAR
4	2	5CAM9124	TUB PIVOT LOCK, RIGHT HAND FRONT/ LEFT HAND REAR
5	2	3CAM9125	LATCH LOCK HANDLE
6	2	3CAM9155	LATCH INDICATOR FLAG
7	2	3CAM9156	SPACER
8	4	1AFAP2407	SNAP RING, 1" EXTERNAL, HEAVY DUTY
9	2	1ABAP4208	GRIP, .843" ID X 4" OAL
10	2	1AFBM3727	PIN, LATCH LOCK, 3/4" X 10-3/8" OAL
11	4	1AFBP3033	WASHER, FLAT, 3/4", PLATED, STANDARD, TYPE A, SERIES W
12	2	1AFBP3066	COMPRESSION SPRING RIGID HITCH
13	2	1AFBP3080	NUT, HEX JAM, 5/8"-11, GRADE 2
14	4	1AFBP3097	HEX CAP SCREW, 5/8"-11 X 1-1/2", GRADE 5, PLATED
15	2	1AFBP3110	HEX CAP SCREW, 5/16"-18 X 2", GRADE 5, PLATED
16	8	1AFBP3215	MACHINERY BUSHING, 1-1/2" OD X 1" ID, 14 GAUGE, PLATED
17	2	1AFBP3298	HEX CAP SCREW, 5/8"-11 X 5-1/2", GRADE 5, PLATED
18	2	1AFBP3504	PIN, HAIRCLIP, 1/8"
19	6	1AFBP3615	NUT, HEX LOCK, 5/8"-11, GRADE 8, PLATED
20	2	1AFBP3644	NUT, HEX LOCK, 5/16"-18, TOP LOCK

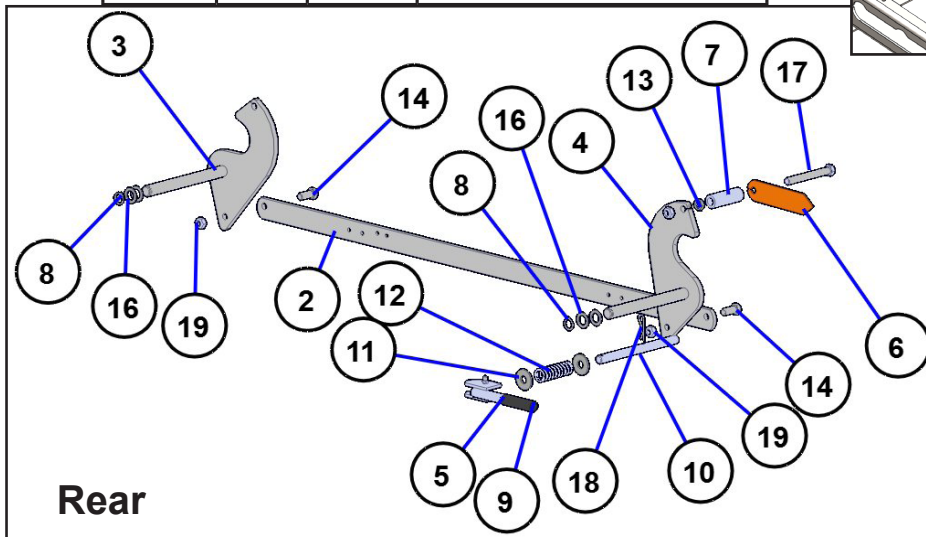
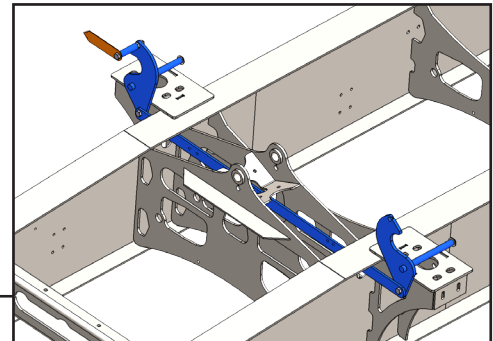
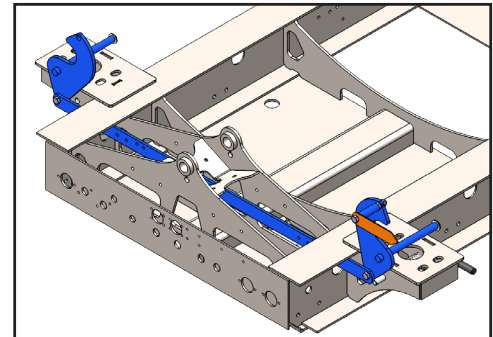

Rear

REMOTE GREASE ZERK COMPONENTS

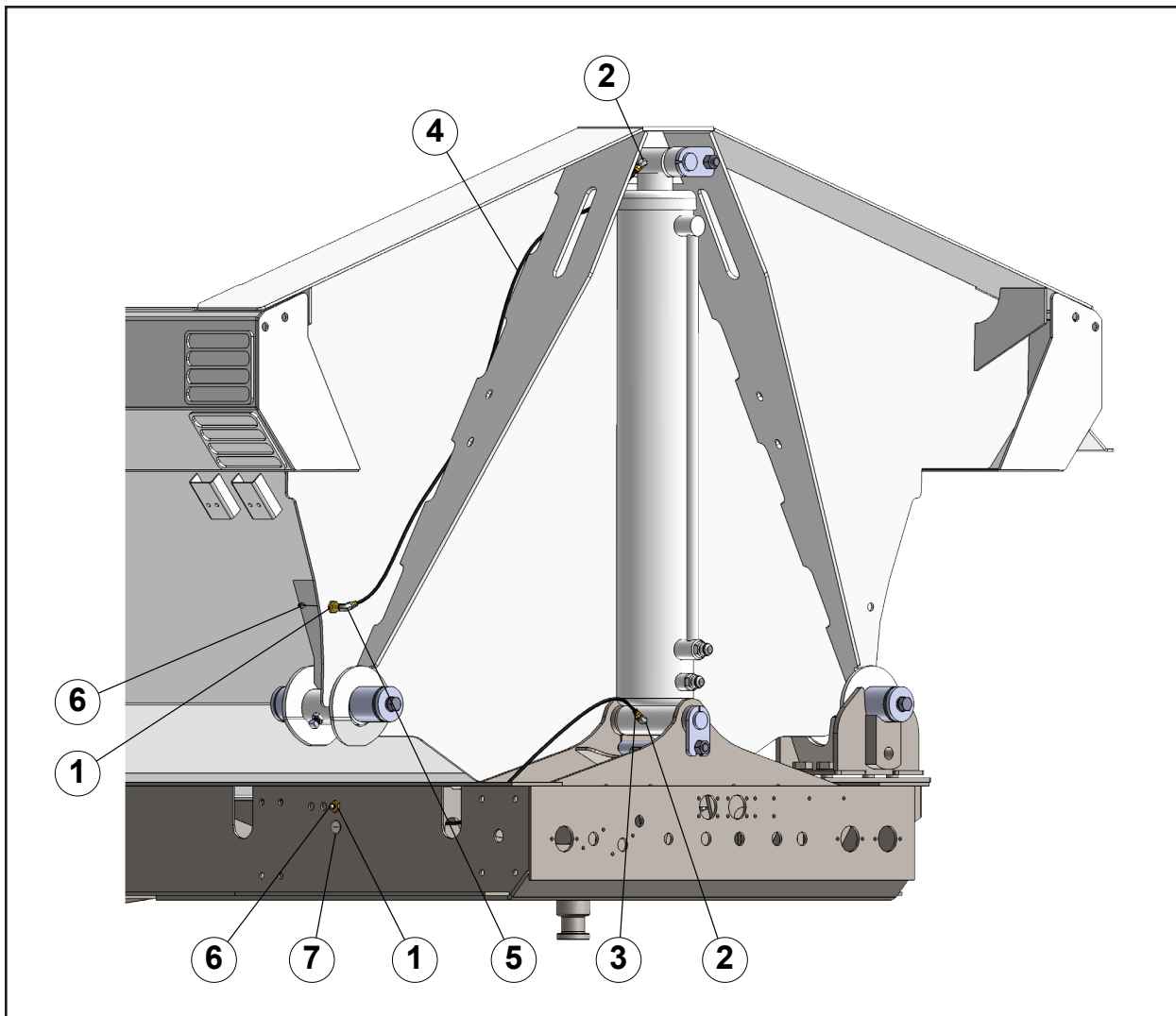

BOM ID	Qty	Item No	Description
1	4	1AFBP3423	BULKHEAD FITTING, 1/8" FNPT - 1/8" FNPT
2	4	1AKEABAAAA0	45 DEG ELBOW ADAPTER, 1/8" FNPT X 1/8" MNPT
3	2	1AKHAAAAA0	1/8" X 50" GREASE HOSE, 1/8" MNPT RIGID X 1/8" MNPT SWIV
4	2	1AKHAAAAA1	1/8" X 60" GREASE HOSE, 1/8" MNPT RIGID X 1/8" MNPT SWIV
5	2	1AKLABAAAA0	90 DEG ELBOW ADAPTER, 1/8" FNPT - 1/8" MNPT
6	4	1AKZAAA0000	1/8"-27 GREASE ZERK, STRAIGHT, PLTD
7	4	1AQBC015065	DECAL, GREASE GUN, RED ON WHITE

Important: Install new safety decals and reflectors if the old decals and reflectors are destroyed, lost, painted over or cannot be read. When parts are replaced that have decals or reflectors, make sure you install a new decal with each new part.

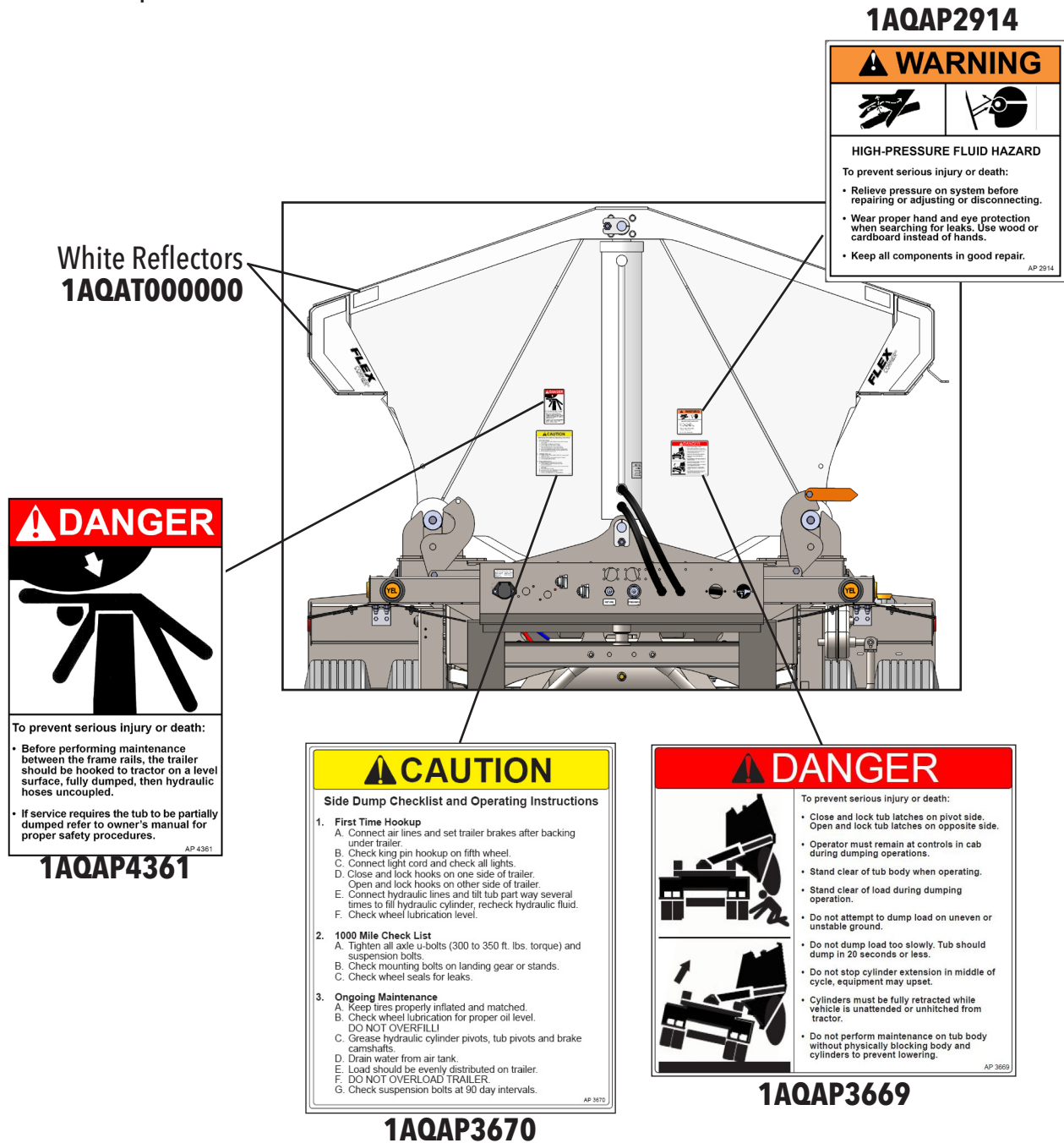

White Reflectors
1AQAT000000

1AQAP2914

WARNING

HIGH-PRESSURE FLUID HAZARD

To prevent serious injury or death:

- Relieve pressure on system before repairing or adjusting or disconnecting.
- Wear proper hand and eye protection when searching for leaks. Use wood or cardboard instead of hands.
- Keep all components in good repair.

AP 2914

DANGER

To prevent serious injury or death:

- Before performing maintenance between the frame rails, the trailer should be hooked to tractor on a level surface, fully dumped, then hydraulic hoses uncoupled.
- If service requires the tub to be partially dumped refer to owner's manual for proper safety procedures.

AP 4361

1AQAP4361

CAUTION

Side Dump Checklist and Operating Instructions

- First Time Hookup**
 - Connect air lines and set trailer brakes after backing under trailer.
 - Check king pin hookup on fifth wheel.
 - Connect light cord and check all lights.
 - Close and lock hooks on one side of trailer. Open and lock hooks on other side of trailer.
 - Connect hydraulic lines and tilt tub part way several times to fill hydraulic cylinder, recheck hydraulic fluid.
 - Check wheel lubrication level.
- 1000 Mile Check List**
 - Tighten all axle u-bolts (300 to 350 ft. lbs. torque) and suspension bolts.
 - Check mounting bolts on landing gear or stands.
 - Check wheel seals for leaks.
- Ongoing Maintenance**
 - Keep tires properly inflated and matched.
 - Check wheel lubrication for proper oil level.
DO NOT OVERFILL!
 - Grease hydraulic cylinder pivots, tub pivots and brake camshafts.
 - Drain water from air tank.
 - Load should be evenly distributed on trailer.
 - DO NOT OVERLOAD TRAILER.**
 - Check suspension bolts at 90 day intervals.

AP 3670

1AQAP3670

DANGER

To prevent serious injury or death:

- Close and lock tub latches on pivot side. Open and lock tub latches on opposite side.
- Operator must remain at controls in cab during dumping operations.
- Stand clear of tub body when operating.
- Stand clear of load during dumping operation.
- Do not attempt to dump load on uneven or unstable ground.
- Do not dump load too slowly. Tub should dump in 20 seconds or less.
- Do not stop cylinder extension in middle of cycle, equipment may upset.
- Cylinders must be fully retracted while vehicle is unattended or unhitched from tractor.
- Do not perform maintenance on tub body without physically blocking body and cylinders to prevent lowering.

AP 3669

1AQAP3669

- 1AQAP3669 (1) DANGER (Load Dumping Safety) 8"W x 5-1/2"L**
- 1AQAP3670 (1) CAUTION (Side Dump Checklist and Operating Instructions) 6"W x 7"L**
- 1AQAP2914 (1) WARNING (High Pressure Fluid) 4"W x 4"L**
- 1AQAP4361 (2) DANGER (Frame Area Maintenance) 3"W x 6-1/4"L**
- *1AQAT000000 (4) White Conspicuity Tape, 2" Wide**

***White Conspicuity Tape is located at both sides of both ends of tub.**

NOTE: New decals and reflectors are available from your dealer.

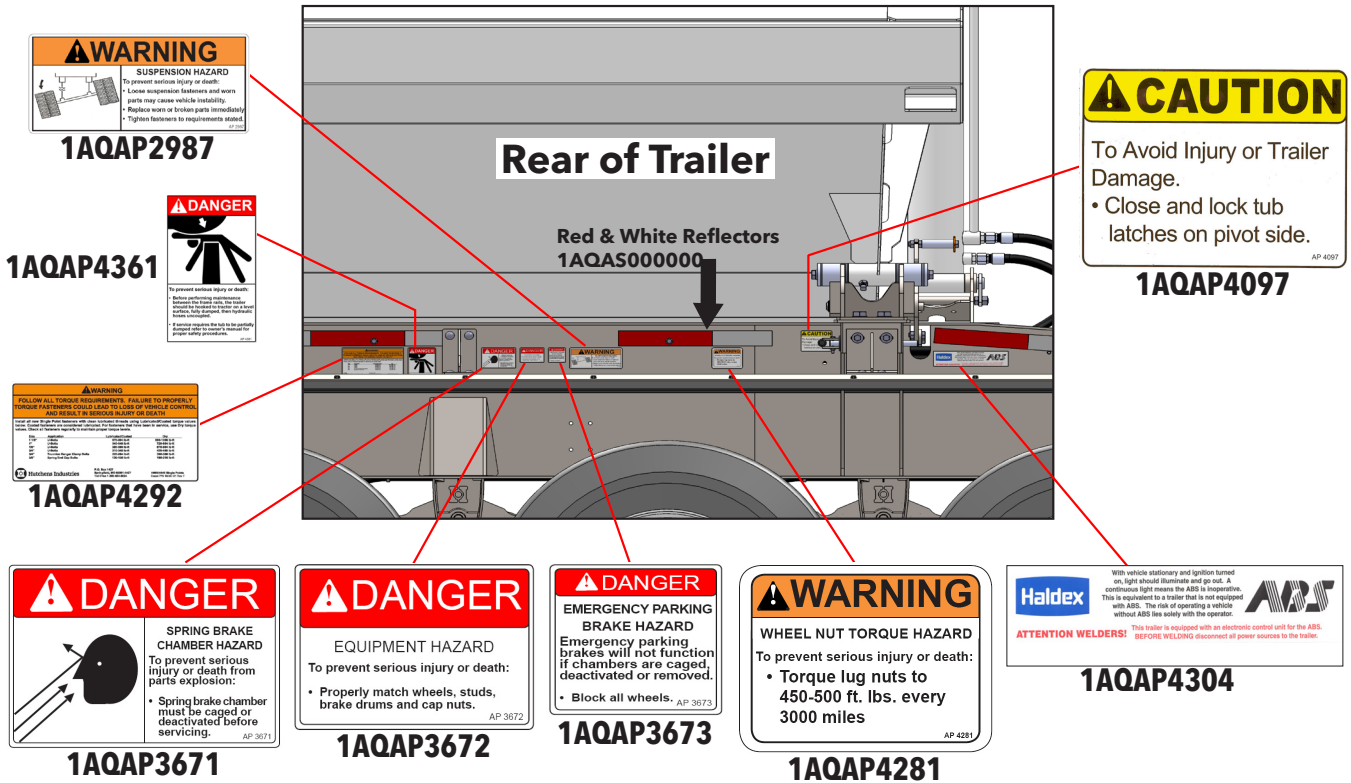

IMPORTANT:

Install new safety decals and reflectors if the existing decals and reflectors are destroyed, lost, painted over, or cannot be read. When parts are replaced that have decals or reflectors, make sure you install a new decal with each new part.

- 1AQAP2987 (1) Decal, WARNING, Suspension Hazard
- * 1AQAP3673 (2) Decal, DANGER Emergency Parking Brake Hazard
- * 1AQAP3672 (2) Decal, DANGER Equipment Hazard
- * 1AQAP3671 (2) Decal, DANGER Spring Brake Chamber Hazard
- 1AQAP4097 (2) Decal, CAUTION, lock tub latches
- 1AQAP4281 (1) Decal, WARNING, Wheel Nut Torque
- † 1AQAP4292 (1) Decal, Hutch Suspension Torque, Orange/Black
- 1AQAP4304 (1) Decal, Haldex ABS Light/ATTN Welders
- 1AQAP4361 (2) Decal, Frame Area Maintenance, Trailer
- † 1AQAP4556 (1) Decal, Holland CBX Swing Align Instruction
- † 1AQAP4557 (1) Decal, Holland CBX Torque Specs

KEY:

- * Safety decals are located at the rear of the trailer on both sides.
- † Spring Ride Trailers only.
- ‡ Air Ride Trailers only.

HOW TO APPLY SAFETY DECALS:

1. Be sure that the installation area is clean and dry.
2. Be sure temperature is above 50°F(10°C).
3. Decide on exact position before removing the backing paper.
4. Remove smallest portion of split backing paper.
5. Align decal over specified area and carefully press the small portion with the exposed adhesive in place.
6. Slowly peel back remaining paper and carefully smooth remaining portions of decal into place.
7. Small air pockets can be pierced with a pin and smoothed out using a piece of decal backing paper.

SWING ALIGN / NON-WELDED AXLE ALIGNMENT PROCEDURES

ALIGNMENT BOLT IS ON THE FRONT OF THE ROADSIDE FRAME BRACKET:

STEP 1. To properly align the suspension, the trailer should be pulled to a straight line for a sufficient distance to ensure frame are to level in the suspension.

STEP 2. Check to verify trailer is level and emergency brakes are NOT engaged.

STEP 3. Rotate bolt **CLOCKWISE** to move axle forward (A arrow), **COUNTERCLOCKWISE** to move axle rearward (B arrow).

ALIGNMENT BOLT TIGHTENING:

NOTE: 1/2 inch of the gap in either direction (A or B)

A = 1/2 inch forward
B = 1/2 inch rearward

1AQAP4556

CBX / CB FIXED FRAME TRAILER AIR SUSPENSION TORQUE SPECIFICATIONS

Torques are with clean, lubricated threads. Always apply torque to nut, if possible.

Fastener Size	Pivot Connection	Shock	Air Spring	Beefing/Align
	1/2"	3/4"	1/2"	3/4"
Torque (ft.-lbs.)	400-500 (800-675)	140-175 (150-225)	80-110 (84-84)	80-100 (88-81)

REQUIRED RE-TORQUING SCHEDULE:

- All fasteners after first three (3) months or 5,000 miles.
- At every routine preventative maintenance.
- At every brake setting.

1AQAP4557

This trailer utilizes SAF-Holland parts including the following:

- A CBX/CB Series Fixed Frame Top Mount Trailer Air Suspension for Disc and Drum Brake Applications, CBX23-245 with 17" ride height
- A PosiLift Air Lift Fixed Frame CBX Series CB-2300 Series.

Sections of the SAF-Holland Original Quick Parts Reference Guide are included with permissions. For questions, please call 1-888-396-6501 or refer to online manuals at SAF-Holland's website: <https://safholland.com/us/en/>

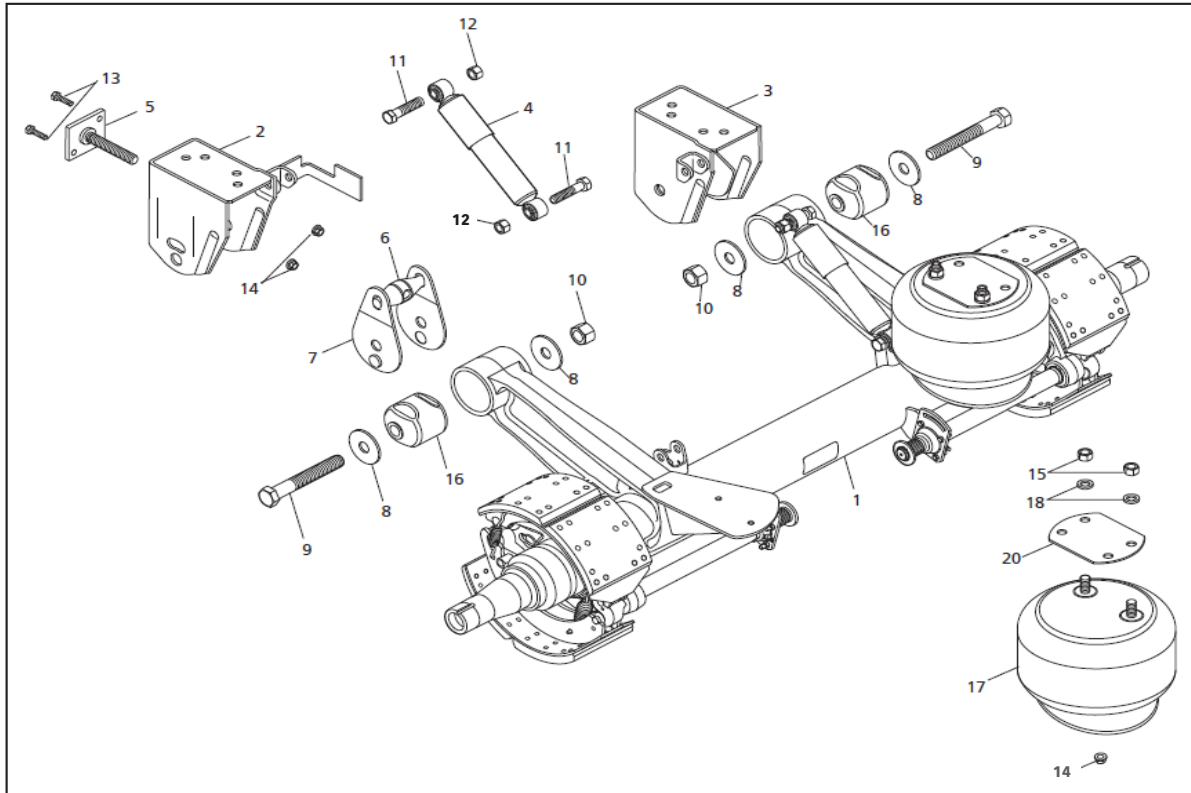

BOM ID	Qty / Axle	Item No	Description
1	-	N/A	CBX23 W/245 AXLE AND BEAM ASSEMBLY
2	1	1ASAP4625	SAF-H FRAME MOUNT, ROAD SIDE, CBX23-245 (90521810)
3	1	1ASAP4624	SAF-H FRAME MOUNT, CURB SIDE, CBX23-245 (90521813)
4	2	1AS90045299	SAF-H SHOCK ABSORBER, 17" RIDE HEIGHT (90045299)
5	1	1ASAP4682	SAF-H THREADED ROD ASSY, CBX SWING-ALIGN (90548007)
6	1	1ASAP4683	SAF-H YOKE, CBX SWING-ALIGN (90045491)
7	2	1ASAP4684	SAF-H PLATE WELDMENT, CBX SWING-ALIGN (90531339)
8	4	1ASAP4685	SAF-H WASHER, 1-1/8" I.D. X 3-1/2" O.D. GR 8 (93600553)
9	2	1AS48100697	SAF-H CBX AXLE PIVOT BOLT W/O POSILIFT (48100697)
10	2	1ASAP4429	SAF-H NUT, HEX LOCK, 1-1/8" - 7 GR C (93400506)
11	4	1AFBP3145	BOLT, HEX HEAD, 3/4" - 10 X 4-1/2", GR 5, PLATED
12	4	1AFBP3442	NUT, HEX, 3/4" - 10, TOP LOCK, GR C, PLATED
13	2	1AFC12HBA05	BOLT, HEX HEAD, 1/2" - 13 X 2", GR 5, PLATED
14	4	1AFC08H0000	NUT, HEX SERRATED FLANGE, 1/2" - 13, PLATED
15	4	1ASAP4687	SAF-H AIR SPRING TOP MOUNT NUT, 3/4" - 16, GR B (93400149)
16	2	1ASAP4688	SAF-H BUSHING ONLY, PIVOT, CAST BEAM, CBX23-245 (90008247)
16A*	-	N/A	SAF-H BUSHING REPAIR KIT, PIVOT, CAST BEAM, CBX23-245 (48100698)
16B*	-	N/A	SAF-H INSTALL TOOL, PIVOT BUSHING, CAST BEAM, CBX23-245 (50544015)
17	2	1ASAP4689	SAF-H AIR SPRING ASSY, 16.0" - 19.0" RIDE HEIGHT (90557399)
18	4	1AF015L0000	WASHER, LOCK, 3/4", PLATED
19*	2	1ASAP4779	STRAP, SHOCK ABSORBER LIMIT, CBX23-245, 17" RIDE HEIGHT

*NOT SHOWN IN ABOVE PARTS DIAGRAM

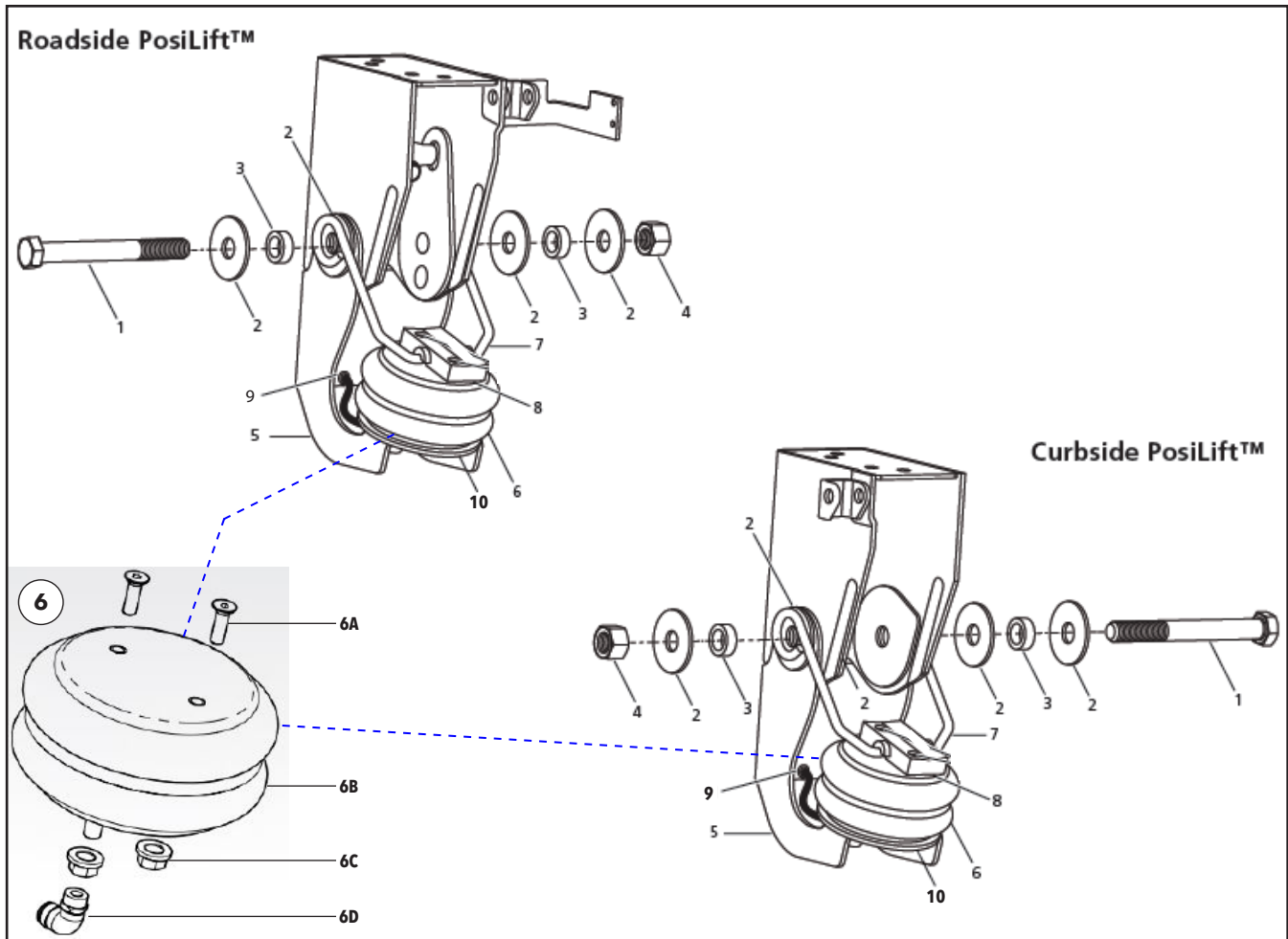

BOM ID	Qty / Axle	Item No	Description
1	2	1AS11005217	SAF-H CBX AXLE PIVOT BOLT W/POSILIFT (11005217)
2	8	1ASAP4685	SAF-H WASHER, 1-1/8" I.D. X 3-1/2" O.D. GR 8 (93600553)
3	4	N/A	SAF-H SPACER, PIVOT BOLT (93900295)
4	2	1ASAP4429	SAF-H NUT, HEX LOCK, 1-1/8" - 7 GR C (93400506)
5	2	N/A	SAF-H CBX POSLIFIT PIVOT MOUNT BRACKET (90026334)
6	2	1ASNS040000	SAF-H AIR SPRING KIT, CBX POSILIFT LIFT BAG (48100497)
6A	4	N/A	SAF-H CAP SCREW, FLAT-HEAD, HEX BIT (93006039)
6B	2	1ASN0040000	SAF-H AIR SPRING, CBX POSILIFT LIFT BAG (90557366)
6C	4	1AFC08H0000	NUT, HEX SERRATED FLANGE, 1/2" - 13, PLATED (93400623)
6D	2	1AB0CL38080	FITTING, 90* ELBOW, 1/8 MPT X 3/8" TUBE (XB-09226)
7	2	N/A	SAF-H CBX POSILIFT GUIDE ARM (90006624)
8	2	N/A	SAF-H CBX POSILIFT BEARING BLOCK (90045590)
9	2	1AR00000094	GROMMET, 3/8" I.D. X 5/8" HOLE (90045591)
10	2	N/A	SAF-H CBX POSILIFT, LIFT AIR SPRING MOUNT PLATE (90034803)

NOTE: ALL SUSPENSION COMPONENTS ON THE LIFT AXLE ARE IDENTICAL TO THE STANDARD AXLE, EXCEPT FOR THE **POSILIFT™** COMPONENTS LISTED ON THIS PAGE.

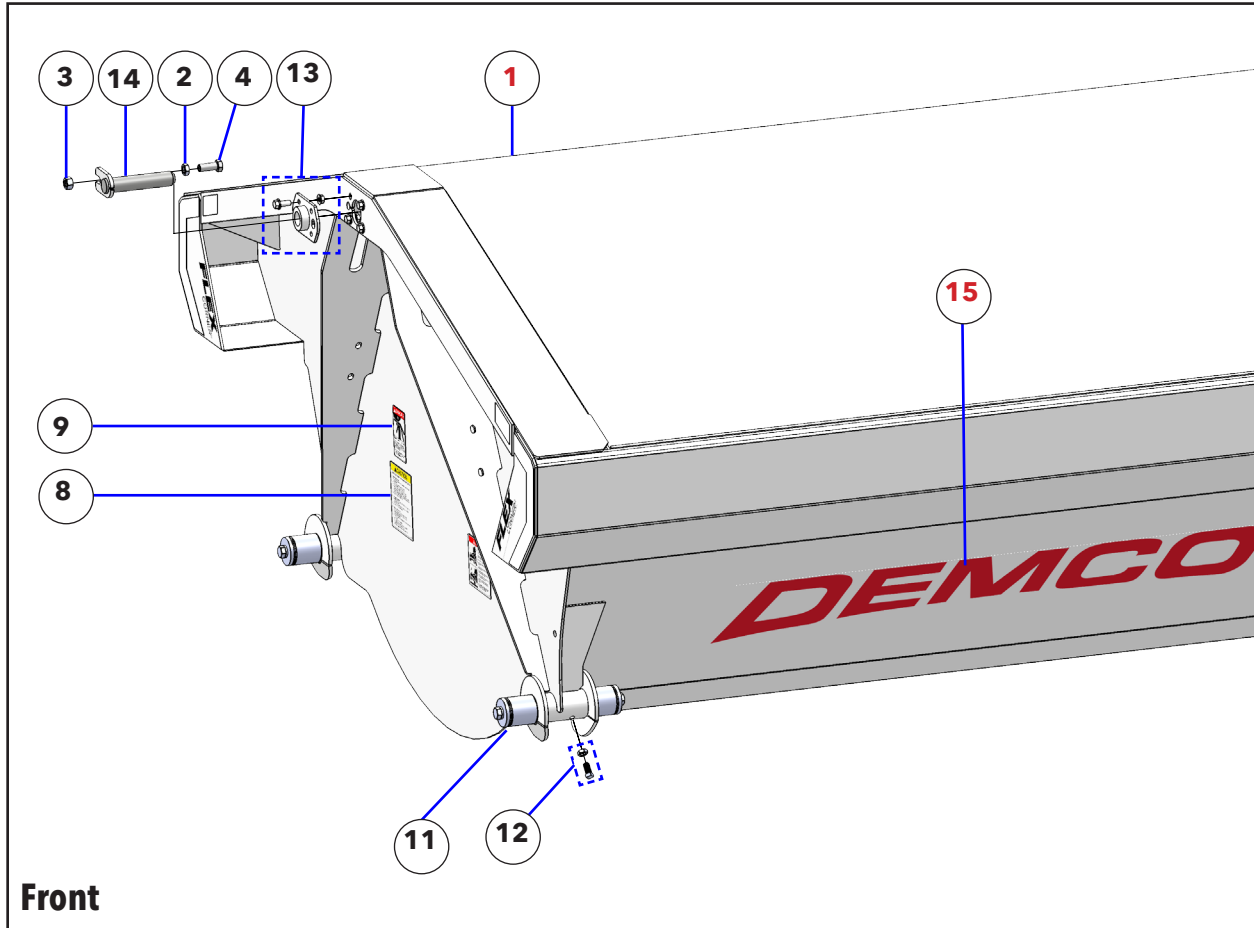

Front

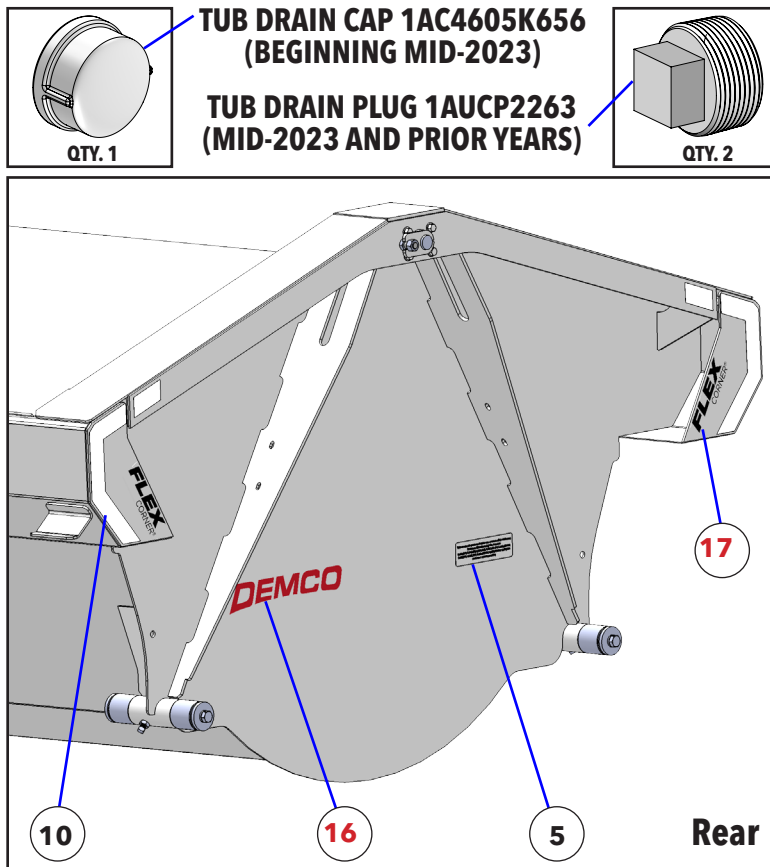

Rear

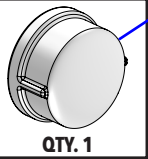

TUB DRAIN CAP 1AC4605K656 (BEGINNING MID-2023)

TUB DRAIN PLUG 1AUCP2263 (MID-2023 AND PRIOR YEARS)

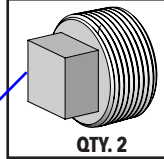

⚠ DANGER

To prevent serious injury or death:

- Before performing maintenance between the frame rails, the trailer should be hooked to tractor on a level surface, fully dumped, then hydraulic hoses disconnected.
- If service requires the tub to be partially dumped refer to operator's manual for proper safety procedures.

AP 2014

1AQAP4361

9

⚠ DANGER

To prevent serious injury or death:

- Close and lock tub latches on pivot side. Open and lock tub latches on opposite side. During dumping operations.
- Operator must remain at controls in cab.
- Stand clear of tub body when operating.
- Stand clear of load during dumping operation.
- Do not attempt to dump load on uneven or unstable ground.
- Do not dump load too slowly. Tub should dump in 20 seconds or less.
- Do not stop cylinder extension in middle of cycle. Equipment may upset.
- Cylinders must be fully retracted while vehicle is unattended or unbraked from trailer.
- Do not perform maintenance on tub body without properly blocking body and cylinders to prevent lowering.

AP 2014

1AQAP3669

7

⚠ CAUTION

Side Dump Checklist and Operating Instructions

- Pre-Tow Checklist
 - Connect air lines and set trailer brakes after backing.
 - Check tire pressure.
 - Check engine fluids on the vehicle.
 - Connect light cord and check all lights.
 - Close and lock hoods on one side of trailer.
 - Open and lock hoods on other side of trailer.
 - Connect hydraulic lines and fill subject way several times to fill hydraulic cylinder. Retract hydraulic fluid.
 - Check wheel lubrication level.
- 100 Mile Check List
 - Tighten all axle bolts (300 to 350 ft. lbs. torque) and suspension bolts.
 - Check mounting bolts on landing gear or stands.
 - Check wheel bolts for tightness.
- Ongoing Maintenance
 - Wear proper wheel and tire method.
 - Check wheel lubrication for proper oil level. (DO NOT OVERLUB.)
 - Check hydraulic cylinder pinents, tub pins and brake assemblies.
 - Load should be evenly distributed on trailer.
 - Use proper hand and eye protection when searching for leaks. Use wood or cardboard instead of hands.
 - Check suspension bolts at 90 day intervals.

AP 2014

1AQAP3670

8

⚠ WARNING

HIGH-PRESSURE FLUID HAZARD

To prevent serious injury or death:

- Relieve pressure on system before repairing or adjusting or disconnecting.
- Wear proper hand and eye protection when searching for leaks. Use wood or cardboard instead of hands.
- Keep all components in good repair.

AP 2014

1AQAP2914

6

This product is protected under one or more of the following Demco Patents:
 5,480,214; 5,845,971; 6,257,670 B1; 6,402,453 B1;
 6,425,726; 6,428,264; 6,488,340 B2; 6,520,589 B2; 6,554,364
 and other patents pending

5

1AQAP2491

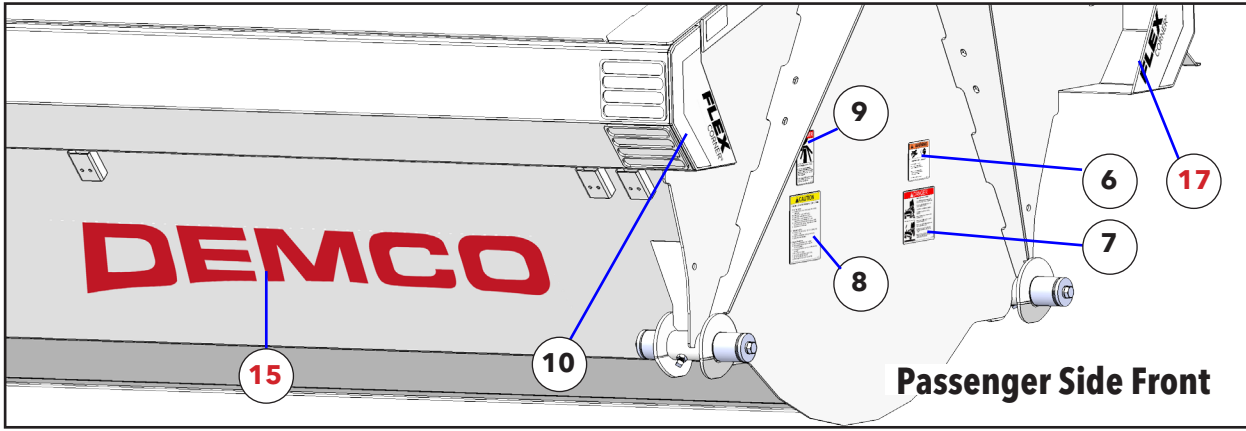

NOTE: A **RED BOM ID#** indicates an option.

BOM ID	Qty	Item No	Description
1	1	5C000278	MY24 37' TUB, 1/4" AR450
1	1	5C000309	MY24 37' TUB, 3/16" AR450
2	2	1AFBP3107	NUT, HEX JAM, 3/4"-10, GR 2, PLTD
3	2	1AFC05L0005	NUT, HEX LOCK, 3/4"-10, GR 2, PLTD
4	2	1AFC12LBAH8	HEX BOLT, 3/4-10 x 2-1/2, GR 8, YELLOW ZINC
5	1	1AQAP2491	DECAL, PATENT PROTECTION, 8-1/2"W X 2-1/2"L
6	1	1AQAP2914	DECAL, WARNING (HIGH-PRESSURE FLUID) 4"W X 4"L
7	1	1AQAP3669	DECAL, DANGER (LOAD DUMPING SAFETY) 8"W X 5-1/2"L
8	1	1AQAP3670	DECAL, CAUTION (SIDE DUMP CHECKLIST & INST) 6"W X 7"L
9	1	1AQAP4361	DECAL, DANGER (FRAME AREA MAINT) 3"W X 6-1/4"L
10	4	1AQAT000000	WHITE CONSPICUITY TAPE, 2" WIDE
11	4	4CFK2005	PIVOT PIN & BUSHING KIT (See sub-assembly parts list below)
12	4	4CAAM7991	ASSEMBLY, SET SCREW & JAM NUT, 5/8"-11 X 1-1/4", PLTD
12A	4	1AFBP3080	NUT, HEX JAM, 5/8"-11, GR 2, PLTD
12B	4	1AFBP3673	SET SCREW, SQ HEAD, 5/8"-11 X 1-1/4", PLTD
13	2	5C000015	ADJUSTABLE TOP CYLINDER MOUNT ASSEMBLY
13A	4	1AFC08H0000	NUT, HEX SERRATED FLANGE, 1/2"-13, PLTD
13B	4	1AFC37HAAD5	HEX CAP SCREW, 1/2"-13 X 1-1/4", SERRATED FLANGE HD, PLTD
14	2	5CAM9057	PIN, CYLINDER, 1-1/2" X 7-1/8", ANTI-ROTATION, PLTD
15	2	DE21026	DECAL, DEMCO LOGO, X-LARGE RED
15	2	DE21027	DECAL, DEMCO LOGO, X-LARGE WHITE
16	1	DE21004	DECAL, DEMCO LOGO, SMALL WHITE
16	1	DE21005	DECAL, DEMCO LOGO, SMALL RED
17	4	DE21024	DECAL, FLEX CORNER, BLACK
17	4	DE21025	DECAL, FLEX CORNER, WHITE,

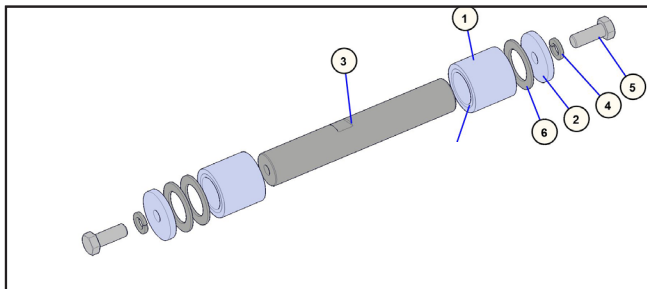

4CFK2005 PIVOT PIN & BUSHING KIT			
BOM ID	Qty	Item No	Description
1	2	4CAAM7990	ASSEMBLY, TUB PIVOT BEARING
2	2	3CAM9026	WASHER, PIVOT PIN
3	1	1AUAM9136	PIVOT PIN, 2" X 12-1/8" OAL, PLTD
4	2	1AF015L0000	WASHER, LOCK, 3/4", PLTD
5	2	1AFBP3139	HEX CAP SCREW, 3/4"-10 X 2", GR 5, PLTD
6	3	1AFBP3599	MACHINERY BUSHING, 3" OD X 2" ID X 10 GA, PLTD

OPTIONAL PARTS SECTION

The following pages contain parts information for accessories that can be added to your Demco Side Dump Trailer.

CENTER MUDFLAP OPTIONS

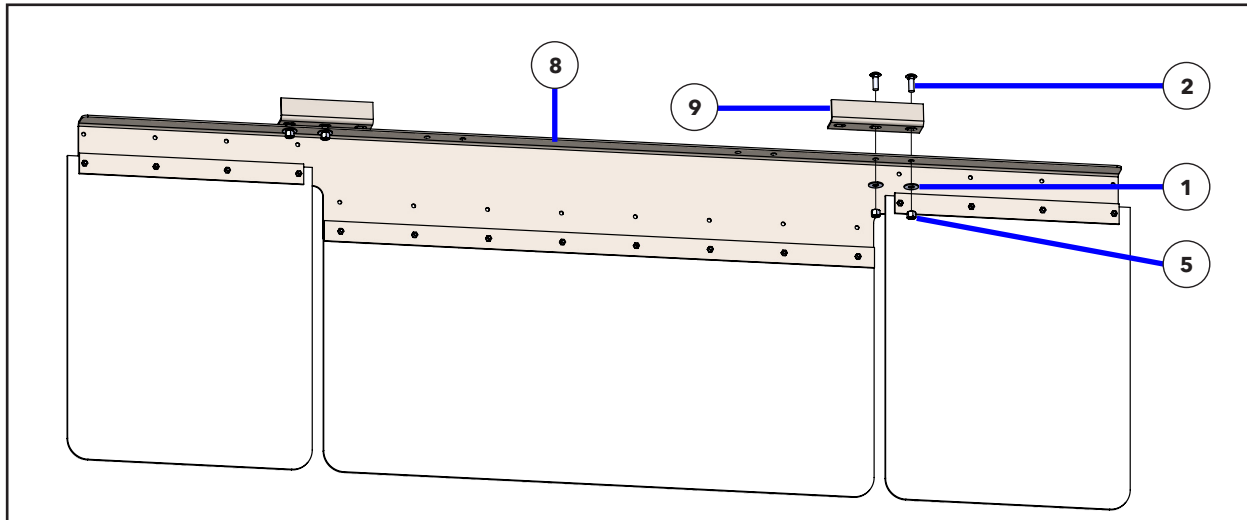
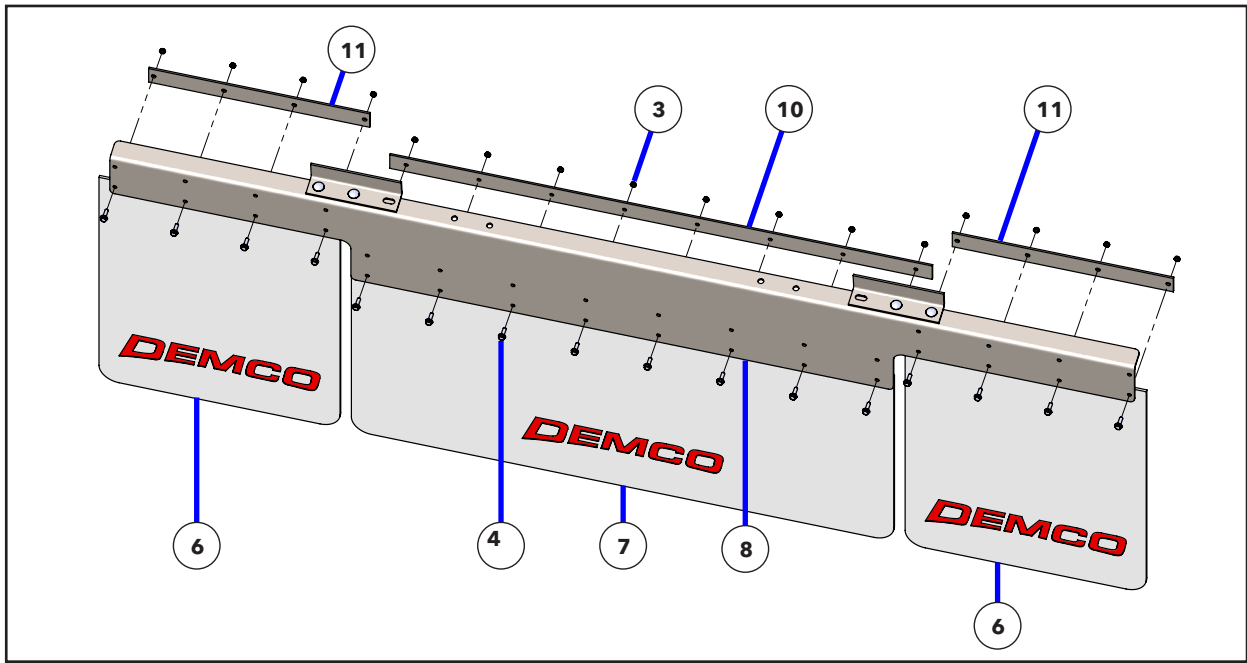

5C000184 (FRONT CENTER MUDFLAP OPTION)

BOM ID	Qty	Item No	Description
1	4	1AF009H0000	WASHER, FLAT, 1/2", PLTD
2	4	1AFBP3232	BOLT, CARRIAGE, 1/2"-13 X 1-1/2", GR 5
3	16	1AFBP3644	NUT, HEX LOCK, 5/16"-18 TOP LOCK, PLTD
4	16	1AFBP3709	BOLT, FLANGE HEAD, 5/16"-18 X 1", GR 8, PLTD
5	4	1AFC18H0000	NUT, HEX LOCK, 1/2"-13, NYLOCK, PLTD
6	2	1AU00000804	MUD FLAP, DEMCO, 24" X 30"
7	1	1AU00000807	CENTER MUDFLAP, 54" X 24.5" W/ LOGO
8	1	3C000178	FRONT CENTER MUDFLAP BRKT
9	2	3C000179	FRONT CENTER MUDFLAP CLAMP
10	1	3C000180	CENTER MUDFLAP BACKING STRAP
11	2	3CAM9035	MUDFLAP BACKING STRAP

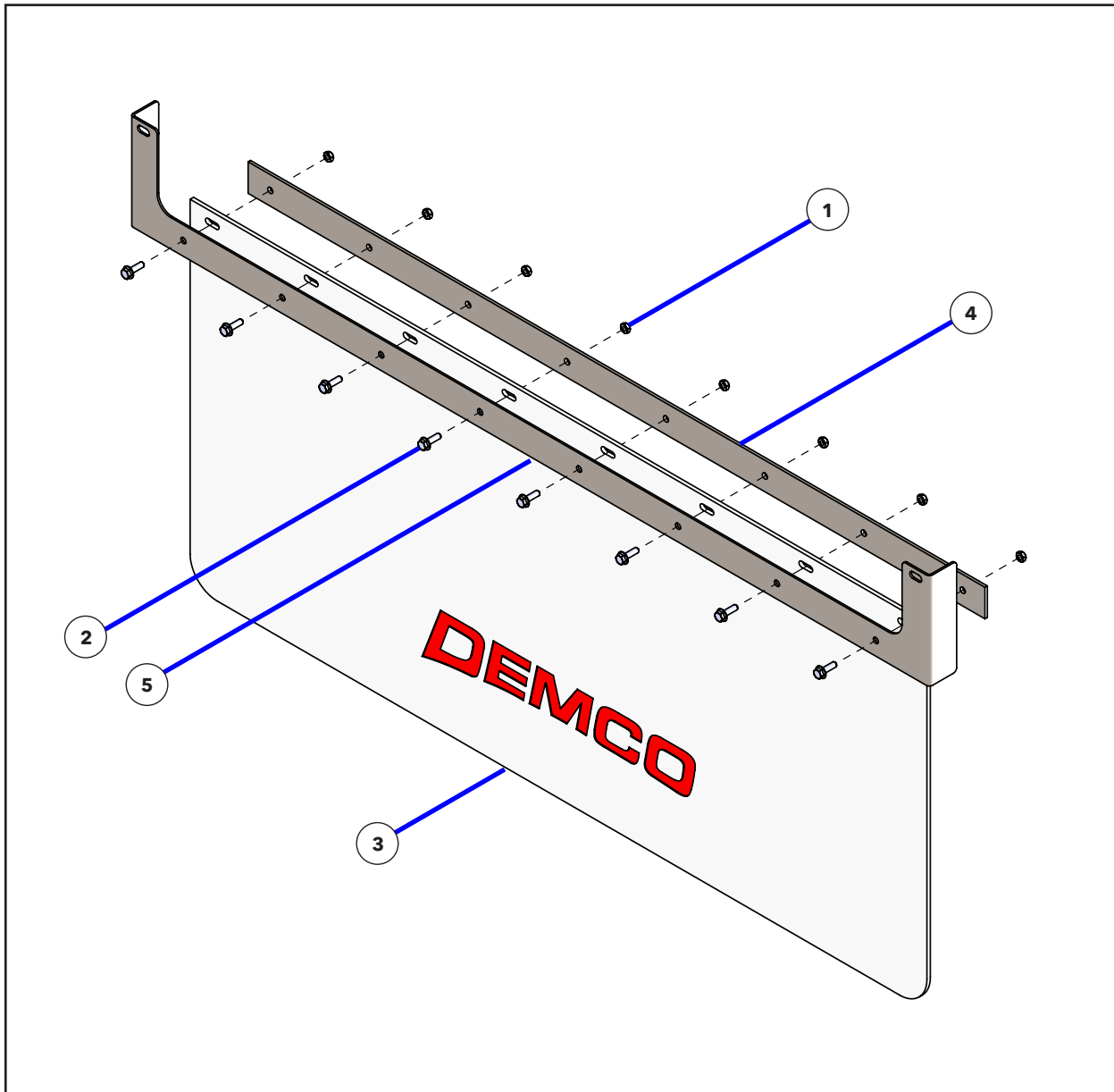

5C000186 (REAR CENTER MUDFLAP OPTION)			
BOM ID	Qty	Item No	Description
1	8	1AFBP3644	NUT, HEX LOCK, 5/16"-18 TOP LOCK, PLTD
2	8	1AFBP3709	BOLT, FLANGE HEAD, 5/16"-18 X 1, GR 8, PLTD
3	1	1AU00000807	CENTER MUDFLAP, 54" X 24.5" W/ LOGO
4	1	3C000180	CENTER MUDFLAP BACKING STRAP
5	1	5C000185	REAR CENTER MUDFLAP BRKT WELDMENT

ELECTRIC OVER HYDRAULIC CONTROL OPTION

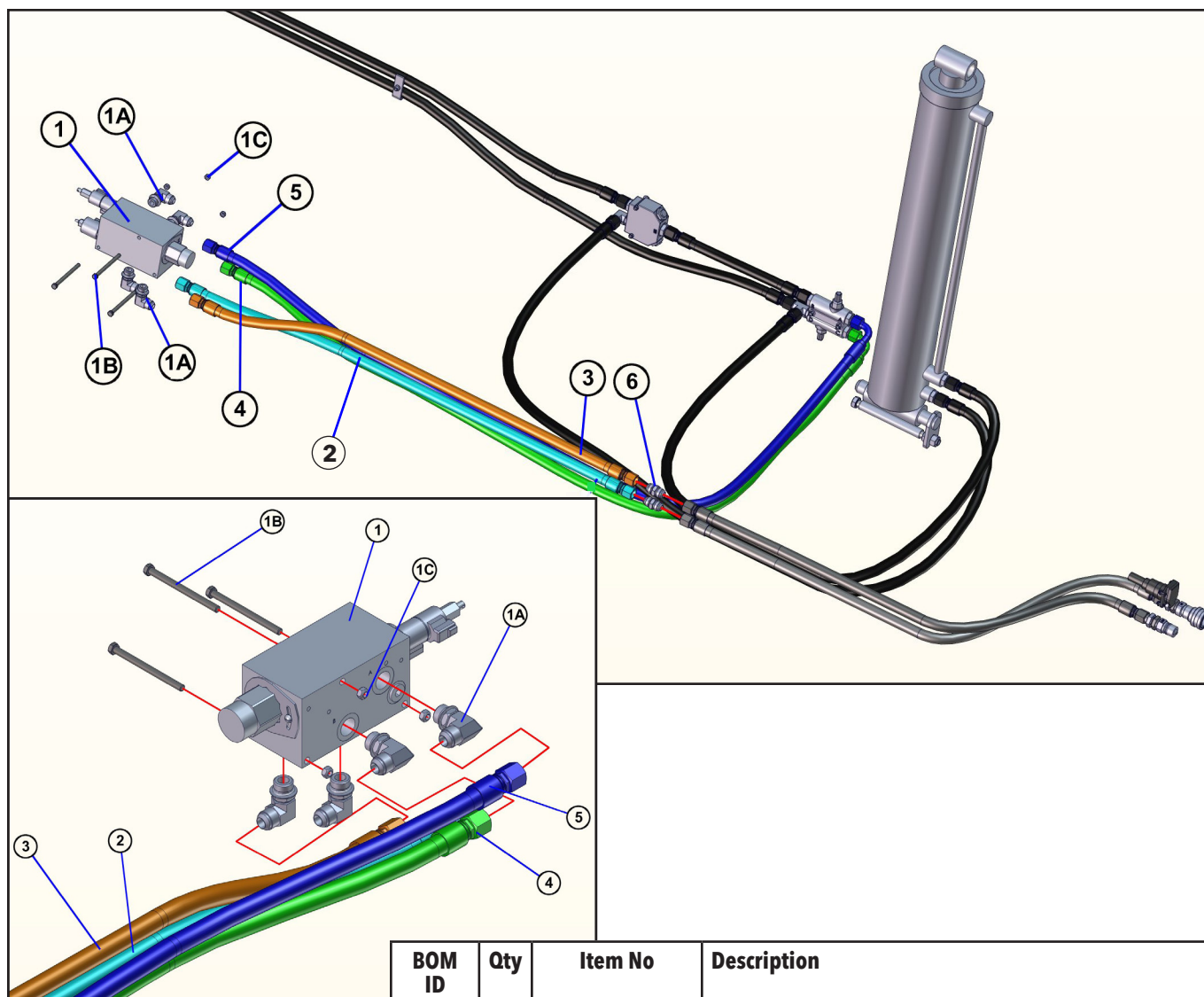

BOM ID	Qty	Item No	Description
1	1	1AAAP4543	VALVE, EOH, TRAILERPRO 302-578
1A	4	1AKDP6538	ADAPTER, 12MJ-12MSAE 90 DEGREE, 6801-12
1B	3	1AFBP3118	HEX CAP SCREW, 3/8"-16 X 5", GR 5, PLTD
1C	3	1AFBP3612	NUT, HEX LOCK, 3/8"-16, TOP LOCK, GR C, PLTD
2	1	1AKDP6546	HOSE, HYDRAULIC, 3/4" X 57", 12FJX-12FJX
3	1	1AKDP6554	HOSE, HYDRAULIC, 3/4" X 53", 12FJX-12FJX
4	1	1AKDP6614	HOSE, HYDRAULIC, 3/4" X 105", 12FJX-12FJX90
5	1	1AKDP6615	HOSE, HYDRAULIC, 3/4" X 108", 12FJX-12FJX90
6	2	1AKDP4388	UNION, 12MJ-12MJ, 2403-12

TO CONVERT YOUR SIDE DUMP TO TRAILER PRO ELECTRIC CONTROLS, CONTACT YOUR DEALER FOR COMPLETE KIT AND PRICING FOR [4CFK2018 \(KIT, TRAILER PRO, EOH VALVE ADD-ON\)](#).

TO ADD A CONTROL BOX TO A SECOND TRACTOR:
CONTACT YOUR DEALER FOR
[4CFK2017 \(KIT, TRAILER PRO CONTROL BOX FOR 2ND TRACTOR, W/ROLL-RITE\)](#)
FOR DEMCO SIDE DUMPS EQUIPPED WITH ROLL-RITE TARPS;

-OR-

CONTACT YOUR DEALER FOR
[4CFK2016 \(KIT, TRAILER PRO CONTROL BOX FOR 2ND TRACTOR, W/AERO\)](#)
FOR DEMCO SIDE DUMPS EQUIPPED WITH AERO TARPS.

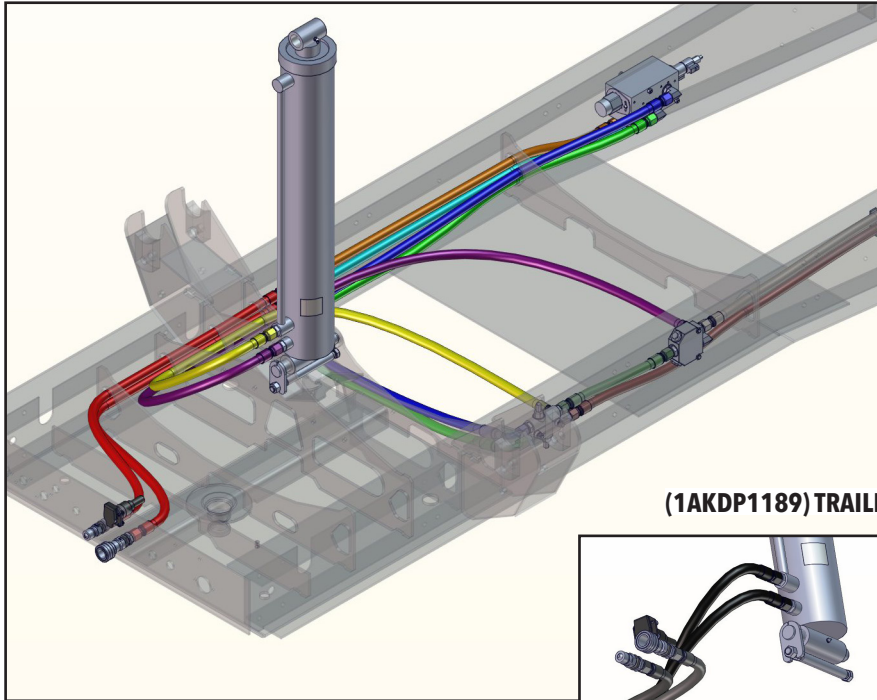

(1AKDP1189) TRAILER PRO HOSE KIT; 4CFK2018

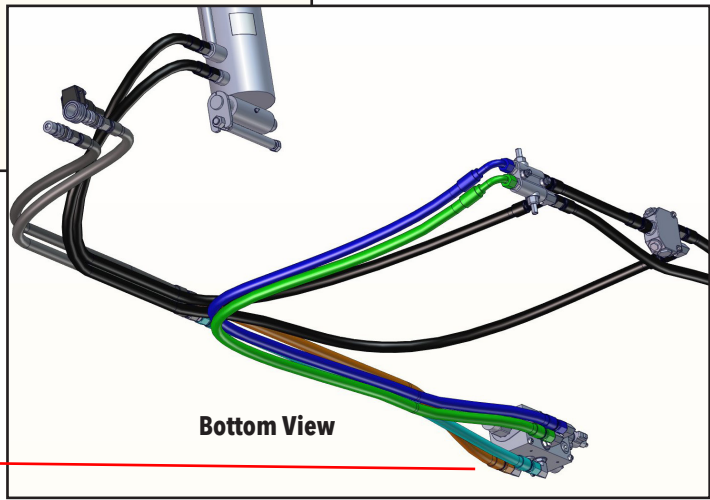

Bottom View

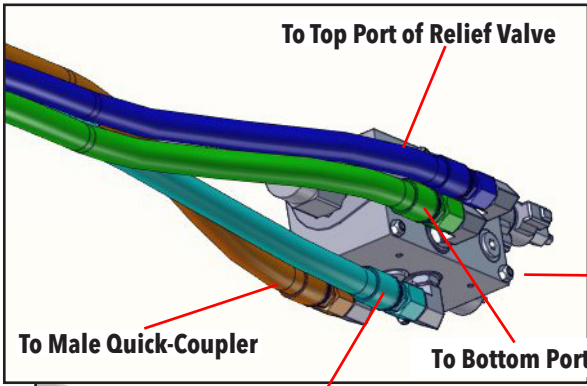

To Male Quick-Coupler

To Top Port of Relief Valve

To Bottom Port of Relief Valve

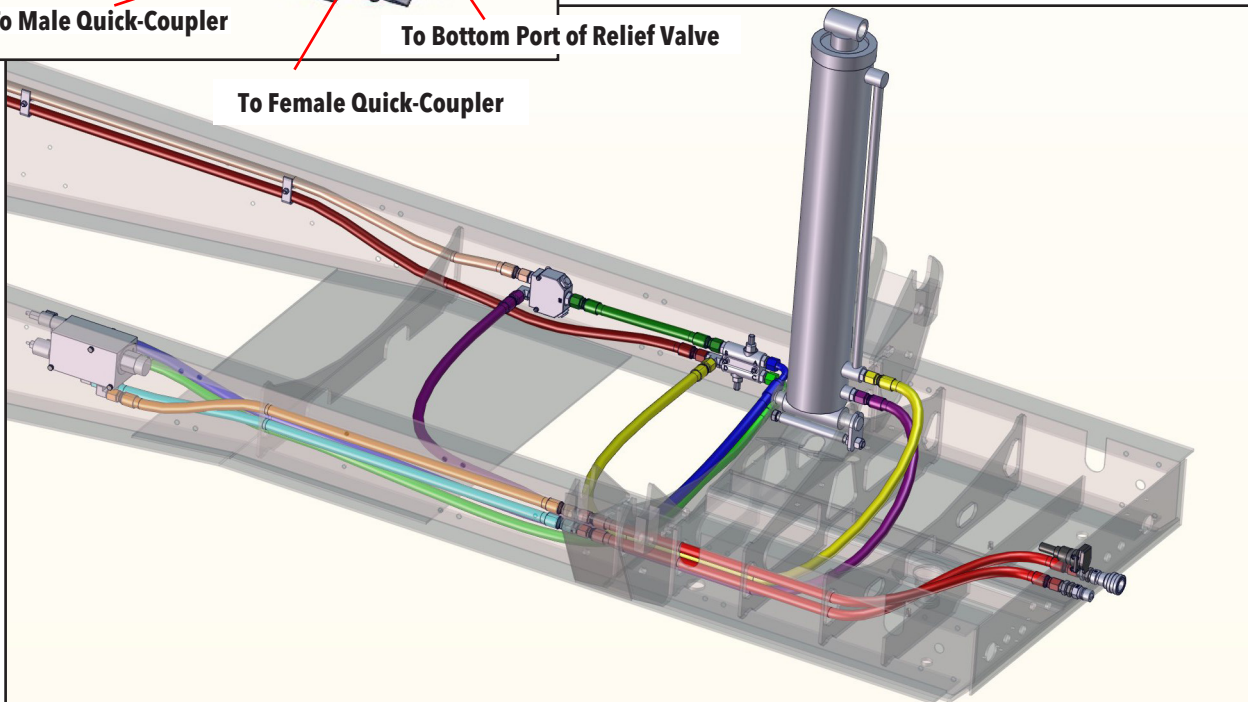

To Female Quick-Coupler

ELECTRIC OVER HYDRAULIC CONTROL OPTION

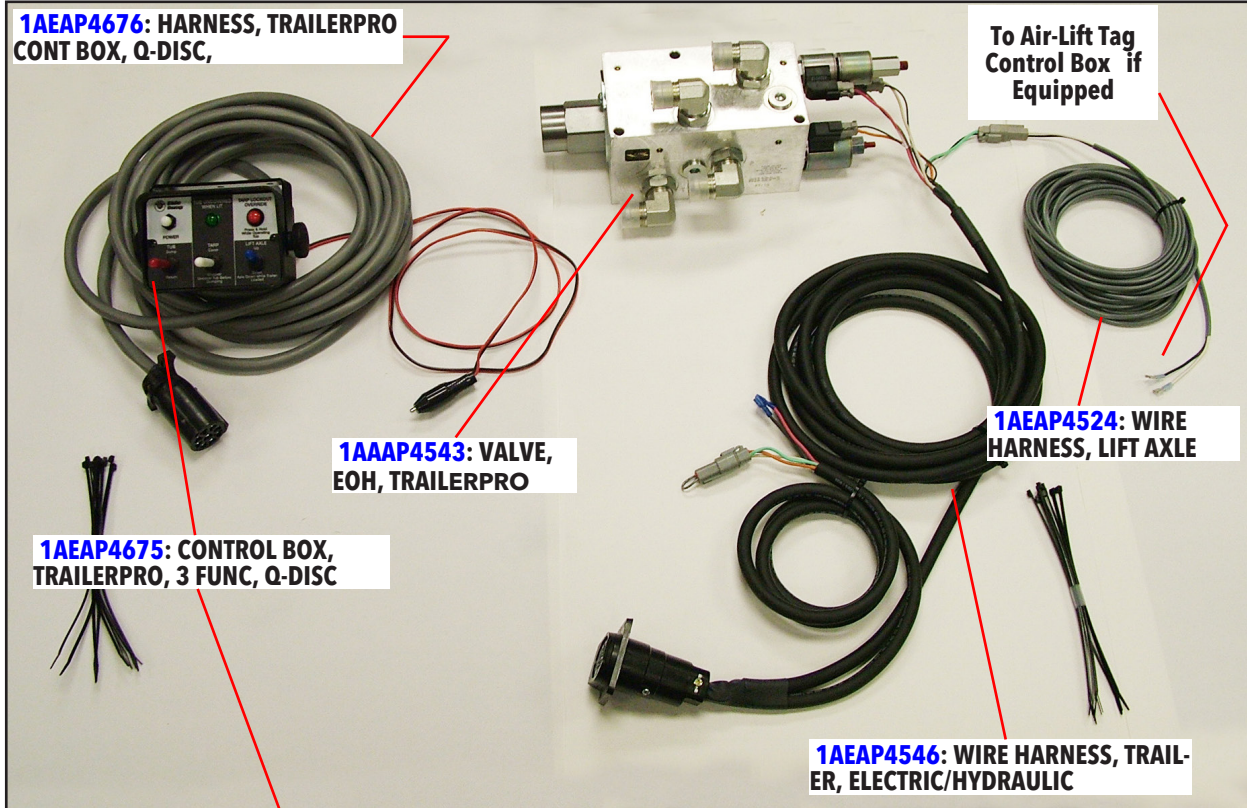

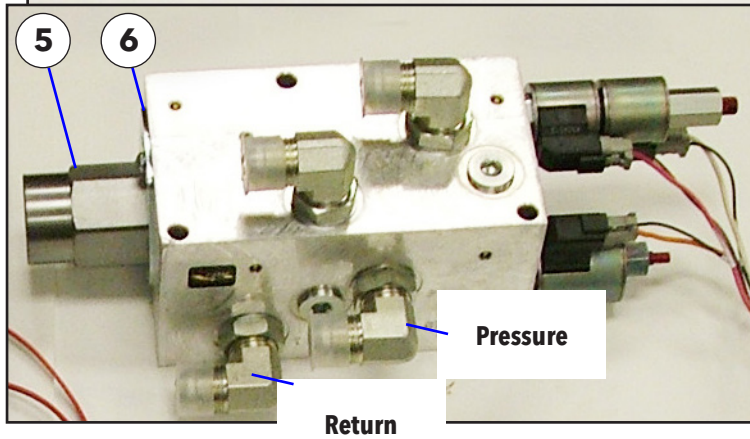
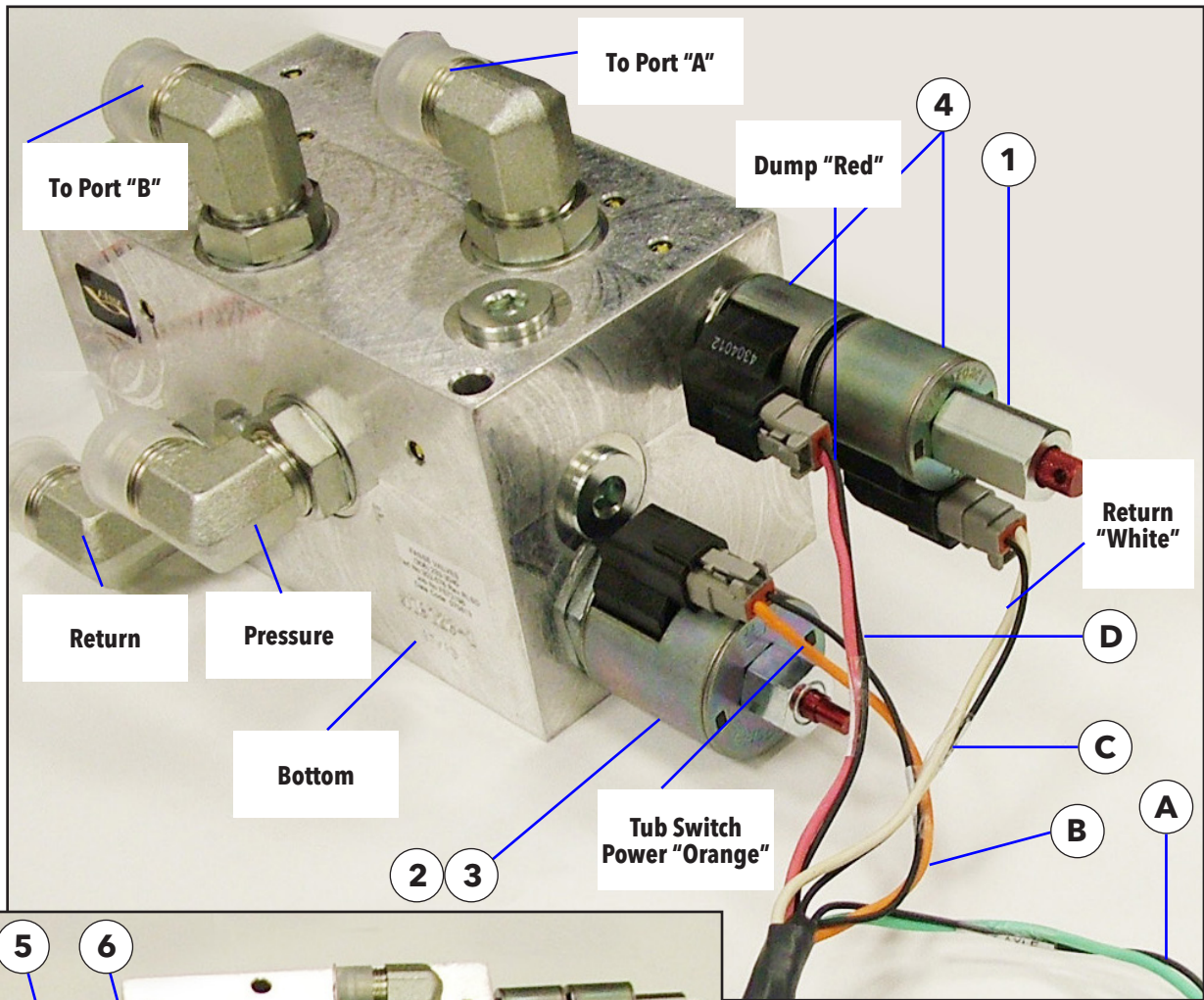

BOM ID	Color	Connection
A	GREEN / BLACK	TO LIFT AXLE
B	ORANGE / BLACK	FLOW CONTROL COIL
C	WHITE / BLACK	DIRECTIONAL CONTROL COIL RETURN
D	RED / BLACK	DIRECTIONAL CONTROL COIL DUMP

BOM ID	Qty	Item No	Description
1	1	1AAAP4590	CARTRIDGE, EOH VALVE, DIRECTIONAL, 273-982
2	1	1AAAP4591	CARTRIDGE, EOH VALVE, FLOW CONTROL, 273-339
3	1	1AAAP4605	COIL, EOH VALVE, 1.81" OD, FLOW CONTROL, 10V, 253-800
4	2	1AAAP4606	COIL, EOH VALVE, 1.43" OD, DIRECTIONAL, 10V, 253-071
5	1	1AK00273340	CARTRIDGE, HYD, HPD42-S67C, 273-340
6	1	1AK00273341	LOCK NUT ADAPTER, CARTRIDGE HYD, 273-341

Installing the Control Box in the Tractor

Find a suitable location in the cab of the tractor and mount the control box. The red and black two wire cable attached to the back of the box is the power cable. Plug the cigarette lighter end into a power outlet in the cab.

If you do not have an available outlet for the cigarette lighter end, use the following instructions:

- Cut the cigarette lighter plug off.
- Split apart the wires and connect the red wire to a 12 volt dc power source and the black wire to ground.
- A bag of terminals is included to allow you to tap into most fuse panels.



WARNING: Red wire must be positive and black wire negative. Reversing these wires can damage the control system. Route the gray cord and male 9 pole plug out of the cab and to the front bulkhead of the side dump. Plug the cord into the female 9 pole socket on the side dump bulkhead.

To operate your Demco side dump, your tractor will need a hydraulic pump that can supply a minimum of 25gpm to the trailer at 2,500 psi. See page 36 for more information on the tractor's hydraulic requirements.

Operating the TrailerPro Control Box

If your side dump is equipped with a tarp, you will also need to wire a power cord from the tractor's battery to the side dump to supply power to the tarp's motor. For wiring instructions, see pages 56-58 for an Aero tarp option or pages 64-66 for a Roll-Rite tarp option. For more detailed wiring instructions, refer to the online Parts Manual.

Press the "Power" button to turn the system on. The button will light up to indicate the power is on. Press the button again to turn the system off.

Dumping the Tub

When the green light in the top center is illuminated, the tub can be dumped. (See Tarp Lock Out Option on next page.)

The red switch in the lower left corner operates the tub. To dump the tub, turn on the tractor's hydraulic pump and then lift and hold the red toggle in the "dump" position to raise the tub and empty its contents. Release the switch when the cylinders reach the fully extended position.



WARNING: Do not stop dumping the load in mid dump and then try to return the tub to the transport position. You may tip over the side dump instead of returning the tub. Push and hold the red switch in the "Return" position to bring the tub back to its transport position. Release the switch when the cylinders are fully retracted.

**Operating the Tarp
(If Equipped)**

The white switch in the lower middle operates the tarp. Lift and hold the white switch to unroll the tarp and cover the tub. Push down and hold the switch to roll the tarp and uncover the tub.

WARNING: When rolling the tarp do not continue to hold the switch after the tarp has reached its fully rolled position. Damage to the tarp or the motor can occur when the motor continues to try to roll the tarp after it has reached its fully rolled position.

**Operating the Lift
Axle (If Equipped)**

The blue switch in the lower right corner controls the lift axle option. Lifting the switch to the up position raises the lift axle and pushing the switch down lowers the lift axle. There is a manual control switch for the lift axle in the gray plastic box at the back of the side dump. There is also a regulator in the box that adjusts the amount of weight the lift axle carries. Instructions are printed inside the box.

WARNING: Always lower the lift axle when the side dump is loaded. Damage to the side dump's frame can occur if the side dump is transported loaded with the lift axle in the raised position.

**Using the Tarp
Lock Out Option**

The Tarp Lock Out prevents the tub from being dumped while the tarp is covering the tub. Dumping the contents of the tub while the tarp covers the tub will ruin the tarp and may cause the side dump to tip over.

If your side dump has a tarp and you purchased the tarp lockout option, the green light and the red button in the top row of the control box will be used. The green light will illuminate when the tarp is in the fully rolled up position.

Once the green light is on, the red switch will be able to operate the tub. If the green light is not illuminated the red switch is "locked out" and the tub can't be moved.

The red button will allow you to dump the tub regardless of the position of the tarp. If the sensor for the green light is damaged or fails, or if you want to tip the tub with the tarp unrolled for maintenance, you can push and hold the red button while using the red switch to move the tub.

CAUTION: If the Tarp Lock Out option is not installed on your side dump, the green light will be illuminated all the time, regardless of the tarp's position.

The Tarp Lock Out can be added to any side dump with a TrailerPro control box. Contact your Demco Dealer for more information. Specify the brand of tarp you have when placing your order.

ELECTRIC TARP OPTION -- AERO

The following Demco mounting parts are needed if an Aero Electric Tarp option is added.

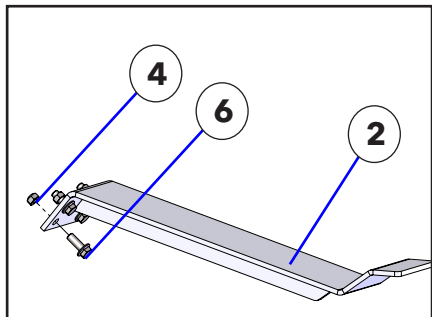
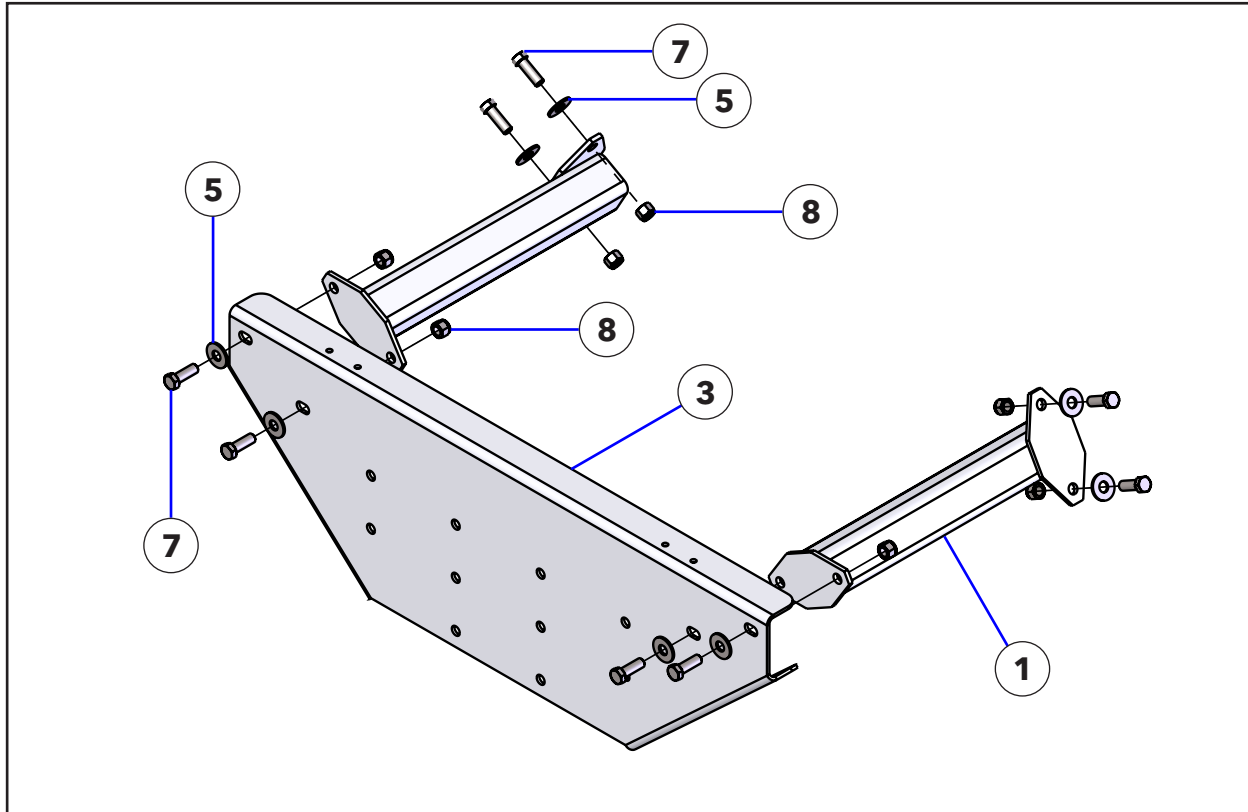

BOM ID	Qty	Item No	Description
1	4	5CAM9038	TARP CHANNEL MOUNT
2	2	5C000008	TARP SUPPORT BRACKET, AERO/ROLL-RITE
3	2	5C000021	AERO TARP MOUNT PLATE ASSY
4	8	1AFBP3612	NUT, HEX LOCK, 3/8-16, TOP LOCK, GR C, PLTD
5	16	1AF009H0000	WASHER, FLAT, 1/2", PLTD
6	8	1AFC12FAA05	HEX BOLT, 3/8-16 X 1", GR 5, PLTD
7	16	1AFC12HAAH8	HEX BOLT, 1/2-13 X 1-1/2", GR 8, PLTD
8	16	1AFC18H0000	NUT, HEX LOCK, 1/2-13, NYLOK, PLTD

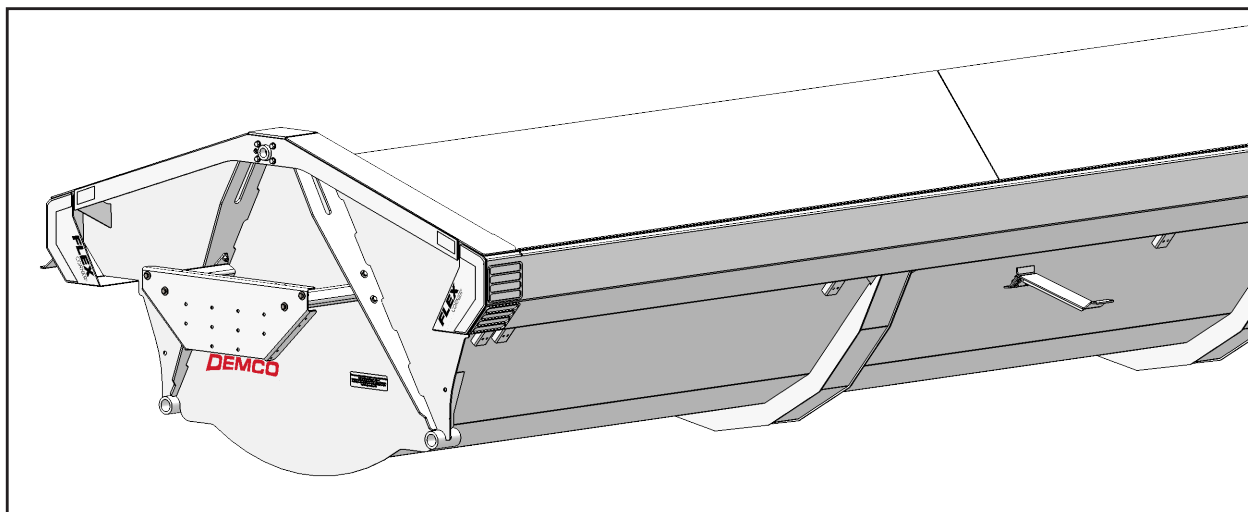

The following pages contain Parts Lists for the Aero Electric Tarp option. For additional questions regarding these parts, contact Aero directly at 1-800-535-9545 or online at www.aeroindustries.com.

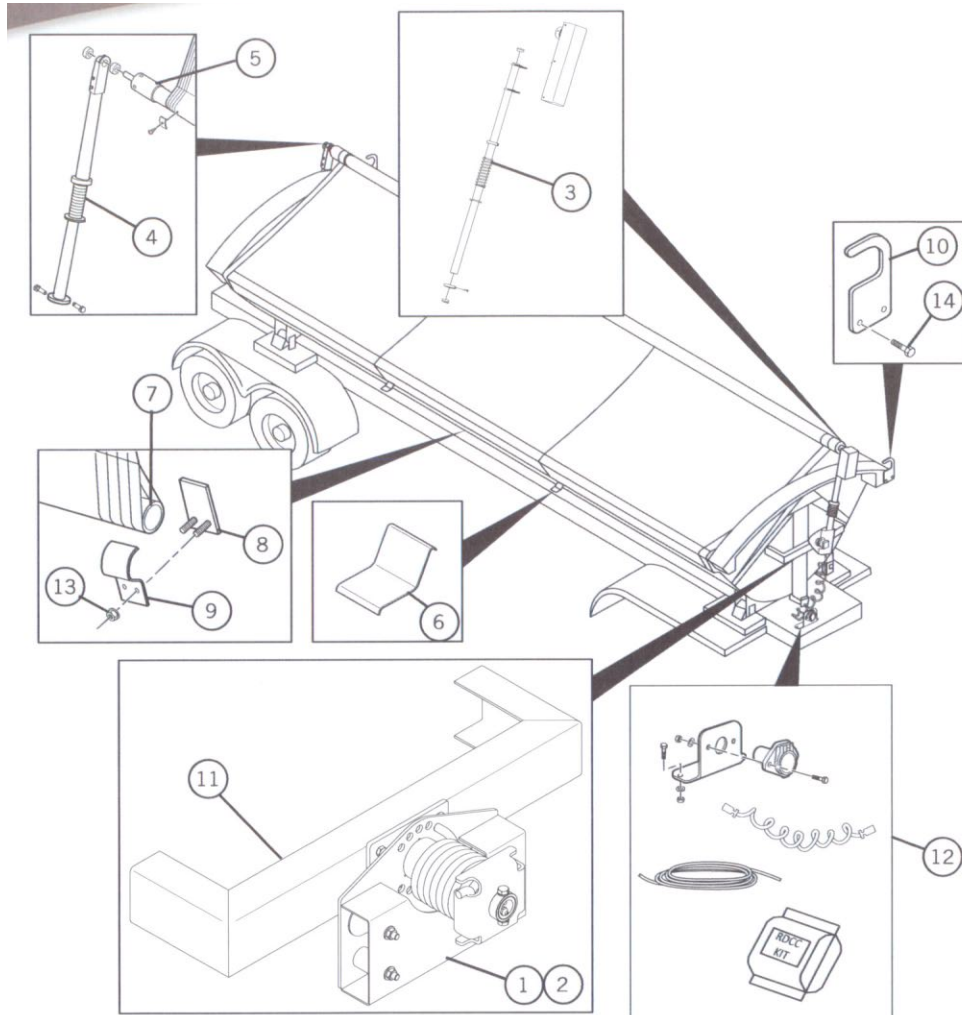

No.	Part No.	Description	Qty	Page
1	1001-961700	Spring Mount Assembly Front	1	19-20
2	1001-961701	Spring Mount Assembly Rear	1	19-20
3	1001-961703	Front Swing Arm Assembly	1	21-22
4	1001-961705	Rear Swing Arm Assembly	1	23
5	1001-961702	Roll Tube Assemble	1	
6	1001-860166	Tarp Cradle	2	
7	1440-281223	Fixed Tube	2	
8	1001-961304	Quick Release Clamp Weldment	7	
9	1040-960158	Quick Release Clamp	7	
10	1001-861320	Tarp Stop Hook	2	
11		Swing Arm Mounting Hardware		18
12		Electrical Hardware		24
13	0815-660210	5/16-18 Flange Nut	14	
14	0810-650510	5/16 Self-Tapping Screw	4	

*Roll Tube Assemble includes the Fixed Tube

Spring Mount Assemblies

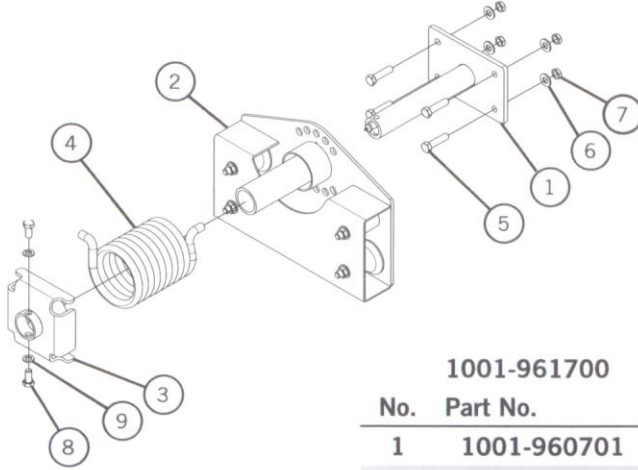

No.	Part No.	Description	Qty
	1001-961700	Spring Mount Assembly Front	
1	1001-960701	Spring Mount Post	1
2	1001-961410	Roller Plate Assembly	1
3	1001-960703	Spring Stop Assy	1
4	1001-861408	SK2 Hub Spring LH	1
5	0810-600002	1/2-13 x 2 Hex Bolt	4
6	0820-680810	1/2 Flat Washer	4
7	0815-660127	1/2-13 NYLOCK Hex Jam Nut	4
8	0810-650553	1/2-13 x 3/4 SHCS	2
9	0820-680820	1/2 Lock Washer	2

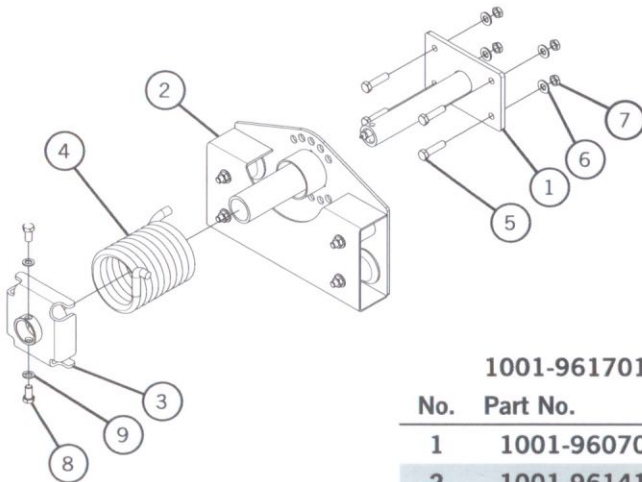

No.	Part No.	Description	Qty
	1001-961701	Spring Mount Assembly Rear	
1	1001-960701	Spring Mount Post	1
2	1001-961410	Roller Plate Assembly	1
3	1001-960703	Spring Stop Assy	1
4	1001-861400	SK2 Hub Spring RH	1
5	0810-600002	1/2-13 x 2 Hex Bolt	4
6	0820-680810	1/2 Flat Washer	4
7	0815-660127	1/2-13 NYLOCK Hex Jam Nut	4
8	0810-650553	1/2-13 x 3/4 SHCS	2
9	0820-680820	1/2 Lock Washer	2

Roller Plate Assembly

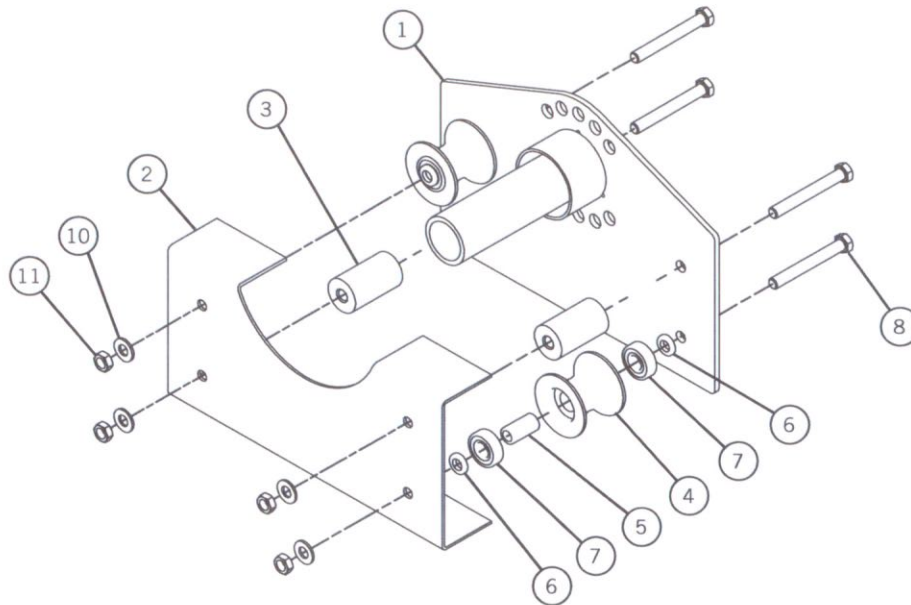

No.	Part No.	Description	Qty
	1001-961410	Roller Plate Assembly	
1	1001-960702	Swivel Collar Assembly	1
2	1001-861411	Roller Plate	1
3	1001-861412	Roller Block	2
4	1001-861325	Roller Radius	2
5	1001-861304	Roller Spacer "V"	2
6	1001-861307	Steel Washer	4
7	0710-602144	Bearing .5" ID x 1.575" OD	4
8	0810-650839	1/2-13 x 4 Hex Bolt	4
9	0815-660127	1/2-13 NYLOCK Hex Nut	4
10	0820-680810	1/2 Flat Washer	4

Front Swing Arm

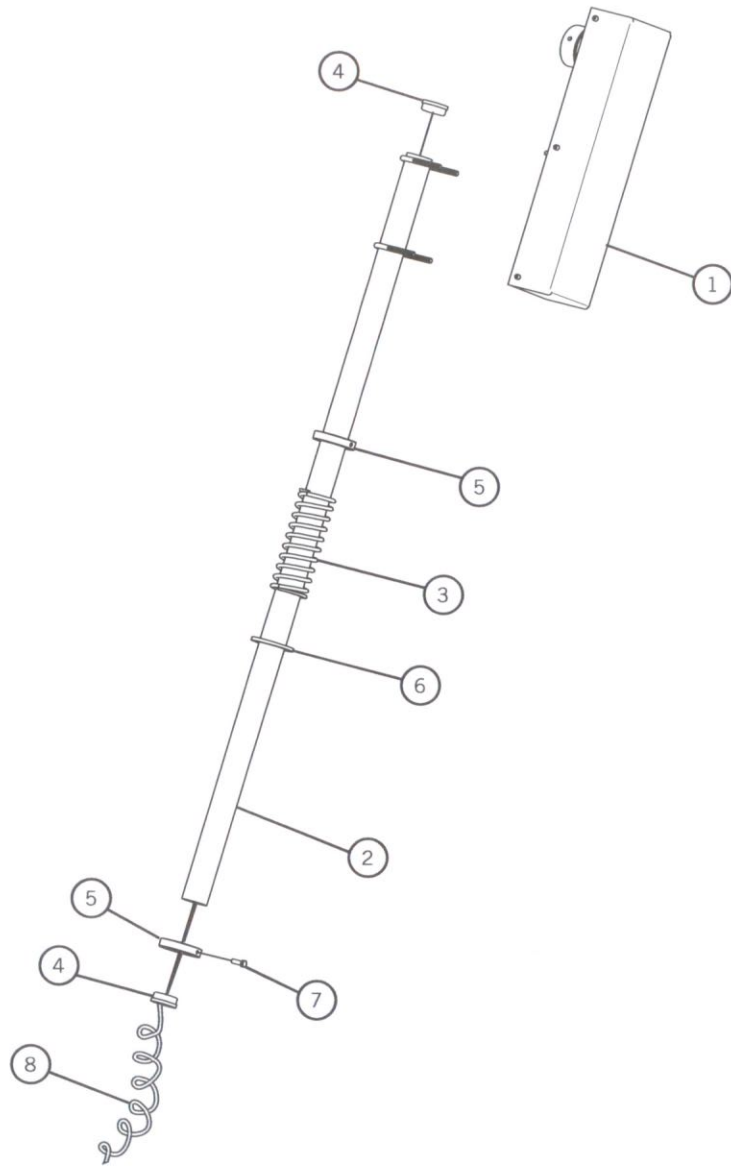

No.	Part No.	Description	Qty
	1001-961703	Front Swing Arm	
1		Motor Drive Unit Assembly (See Page 22)	
2	1440-281635	Steel Tube 2" Rd x 5' Lg	1
3	0715-619405	Compression Spring Jumbo	1
4	1001-861309	Swing Arm Tube Plug	2
5	1001-861316	Collar Lock Swing Arm	2
6	0820-680401	Washer 1/4 x 2 1/4 x 3 1/4	1
7	0810-650170	5/16-18 x 1 Hex Bolt W/Patch	2
8	0755-626433	Flex Cord Motor to Plug	1

Motor Drive Assembly

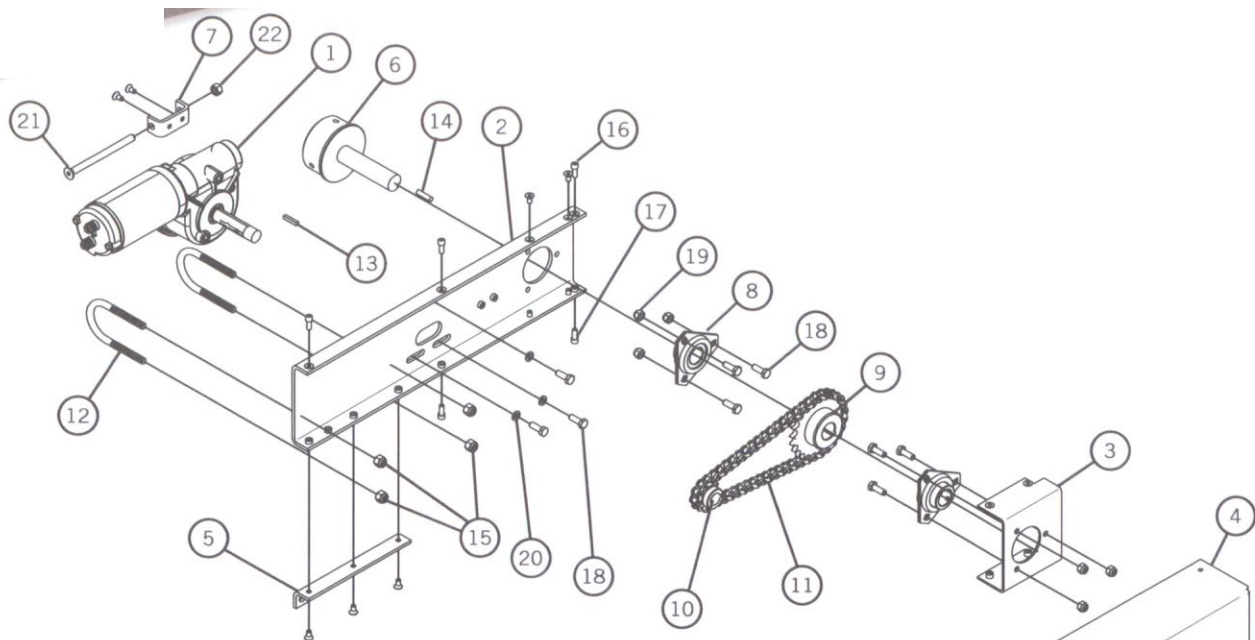

No.	Part No.	Motor Drive Assembly Description	Qty
1	0755-623421	Motor RA/SWB	1
2	1001-960710	Drive Mount Channel Assy	1
3	1001-960711	Bearing Mount Assy	1
4	1001-861722	Drive Unit Cover	1
5	1001-861716	Swing Arm Extension Bracket	1
6	1001-861717	Roll Pipe Adapter	1
7	1001-860704	Chain Tension Bracket	1
8	1001-861714	Bearing Set 1" Bore	2
9	1001-861719	Sprocket 40B24 1" Bore	1
10	1001-861720	Sprocket 40B10 3/4" Bore	1
11	1001-861721	#40 Roller Chain	1
12	1001-861718	U-Bolt 2" Swing Arm Mount	2
13	1001-861723	Key 1/4" x 1"	1
14	1001-861724	Key 3/16" x 1"	1
15	0815-660660	3/8-16 NYLOCK Hex Nut	4
16	0810-650497	1/4-20 x 1/2 FHCS	9
17	0825-617251	1/4-20 x 5/8 SHCS	6
18	0810-650552	5/16-18 x 7/8" Hex Bolt	9
19	0815-660550	5/16-18 NYLOCK Hex Nut	6
20	0820-680520	5/16 Lock Washer	3
21	0810-650496	3/8-16 x 5 FHCS	1
22	0815-661640	3/8-16 Hex Nut	1

Rear Swing Arm

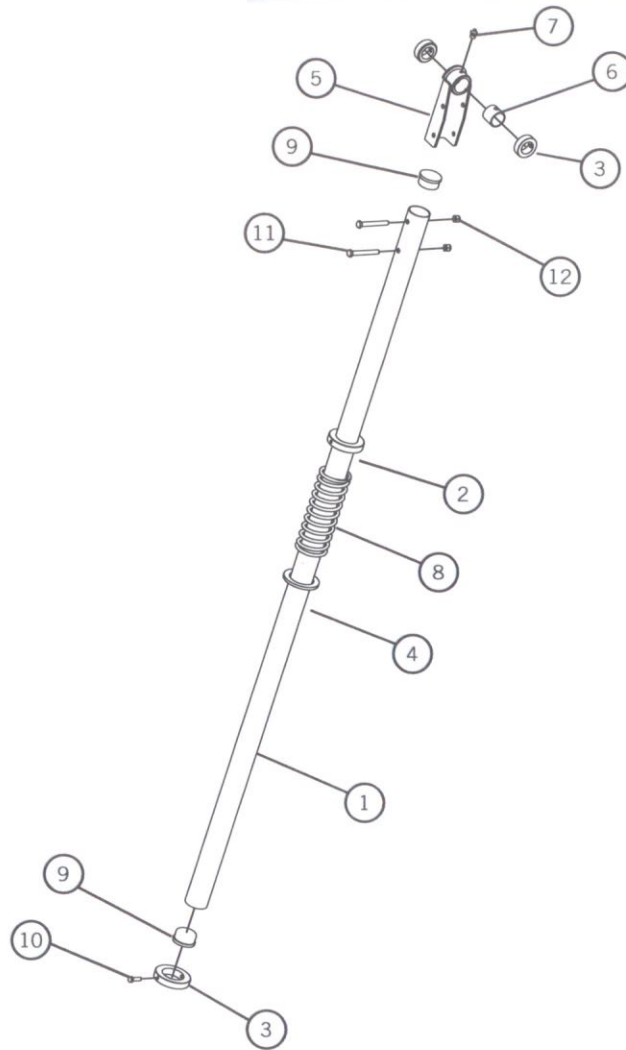

No.	Part No.	Description	Qty
1	1440-281636	Steel Tube 2" Rd x 6' Lg	1
2	1001-861316	Collar Lock Swing Arm	2
3	0785-690335	Collar Shaft 1 1/4" ID	2
4	0820-680401	Washer 1/4 x 2 1/4 x 3 1/4	1
5	1001-962122	Motor Mount Bracket Assy	1
6	0845-691233	Bronze Bushing	1
7	0825-670394	Zerk 1/4-28 Straight	1
8	0715-619405	Compression Spring Jumbo	1
9	1001-861308	Swing Arm Tube Plug-Top	2
10	0810-650170	5/16-18 x 1 Hex Bolt W/Patch	2
11	0810-670657	3/8-16 x 3 Hex Bolt	2
12	0815-660660	3/8-16 NYLOCK Hex Nut	2

Electrical Hardware

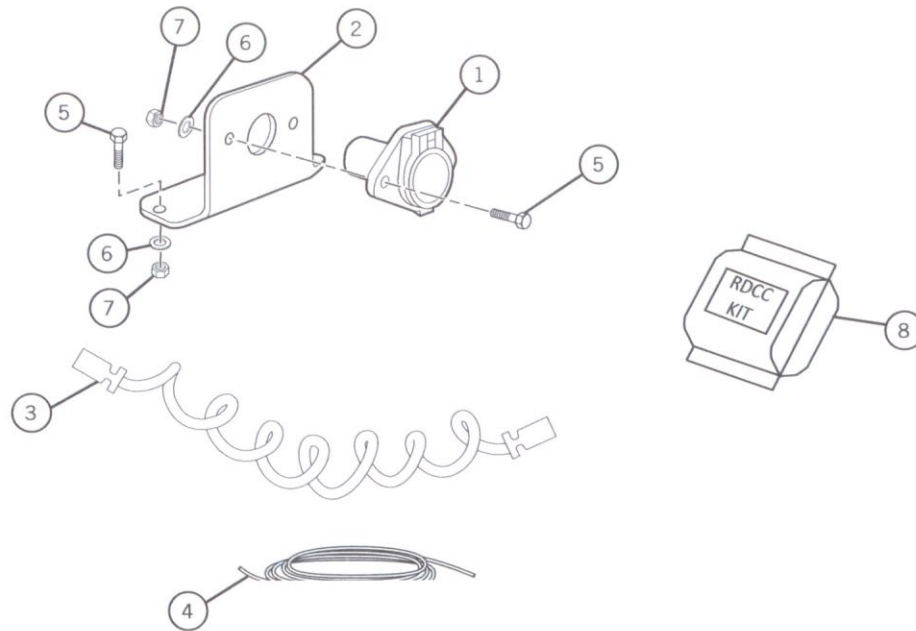

Electrical Hardware			
No.	Part No.	Description	Qty
1	1041-860143	Female Electrical Socket	2
2	1001-860165	Socket Mounting Bracket	2
3	0755-626434	Flex Cord with Plugs	1
4	0755-626540	#6 Wire (20')	1
5	0810-650552	5/16-18 x 7/8 Hex Bolt	4
6	0820-680510	5/16 Flat Washer	4
7	0815-660461	5/16-18 NYLOCK Hex Nut	4
8	0755-962108	RDCC Kit	1

Wiring the Tractor Instructions

There are two items to wire on the tractor before you can operate your Demco side dump. The control box and the tarp power wire.

To install the control box, find a suitable location in the cab of the tractor and mount the control box. The red and black two wire cable attached to the back of the box is the power wire. Plug the cigarette lighter end into a power connection in the cab.

If you do not have an available outlet for the cigarette lighter end, use the following instructions:

- Cut the cigarette lighter plug off.
- Split apart the wires and connect the red wire to a 12v dc power source and the black to ground.

 **Red wire must be positive and Black negative. Reversing these wires can damage the control system.**

- A bag of terminals is included to allow you to tap into most truck fuse panels.

Route the gray cord and male 9 pole plug out of the cab and to the front bulkhead of the side dump. Plug the cord into the female 9 pole socket on the trailer bulkhead. You will now be able to raise and lower the rear axle and dump the tub.

NOTE: Air must be supplied to the side dump for the lift axle to operate properly. Hydraulic oil must be supplied to the side dump to dump the tub.

To use the tarp you will need to supply 12 volt power to the side dump to operate the tarp motor. Due to the large power draw of the tarp motor, the electrical supply must be hooked directly to the battery and the heavy #6 wire included with the kit must be used.

Refer to the Aero wiring diagram for reference. The relay has been already mounted on the side dump and the momentary switch that rolls/unrolls the tarp is in the control box installed previously. All that needs to be done is to run a wire from the battery to the female two pole socket on the road side front corner of the side dump.

Find a suitable location on the tractor to mount the included female two pole socket. A mounting bracket and hardware is also supplied.

Locate the circuit breaker as close to the positive battery post as possible. If the circuit breaker is not mounted to the battery box or truck frame, make sure that the terminals cannot touch anything that would create a short circuit.

Separate enough of the red wire on the #6 red/black cord to reach from the positive battery terminal to the circuit breaker. Cut off the red wire. Strip the red wire and crimp on ring terminals to match the battery cable bolt and the post on the circuit breaker.

 **Do Not hook the red wire to the battery until everything else is wired.**

Crimp a ring terminal on the red wire on the remaining red/black cord and attach it to the circuit breaker.

Crimp a ring terminal on the black wire and attach it to the negative battery post.

Route the red/black cord to the female socket. Cut the cord and crimp ring terminals on the end of the wires.

Slip the cover for the back of the socket over the cord and bolt the ring terminals to the socket. Match the positive and negative wires to the corresponding terminals marked on the socket.

Slip the cover over the back of the socket. Secure the red/black cord to the truck frame.

Hook the red wire to the battery. A double male stretch cord is included to connect the tractor to the side dump.

The tarp will now operate from the control box. It is best to have the tractor running while operating the tarp.

Mounting Parts

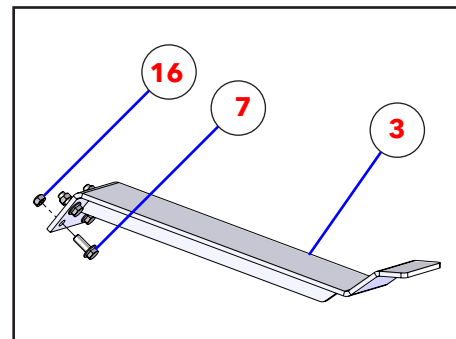
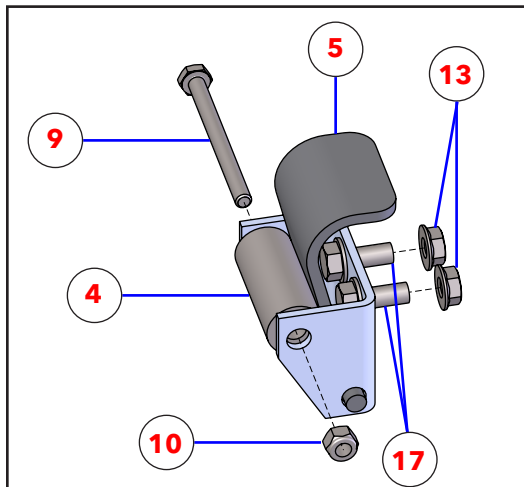
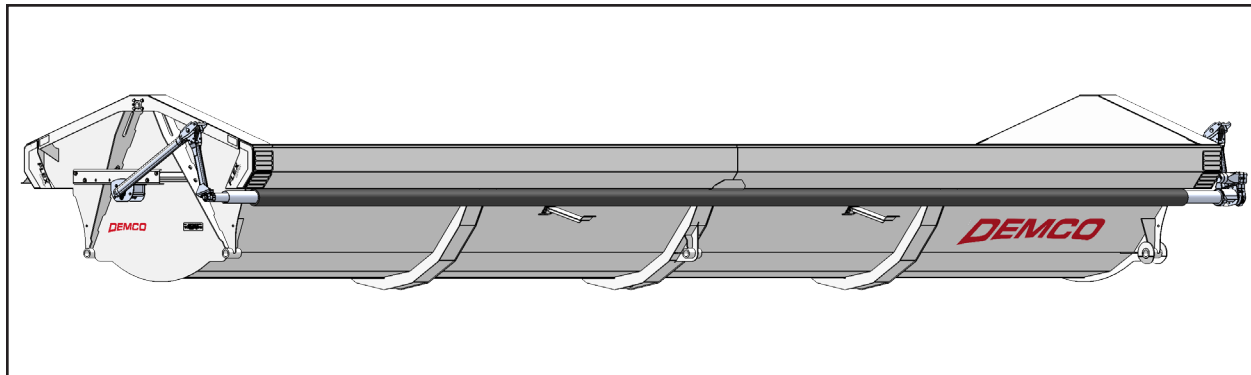
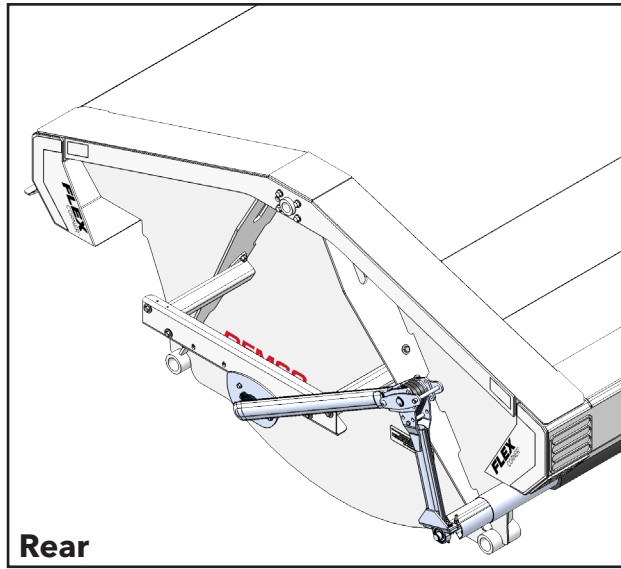
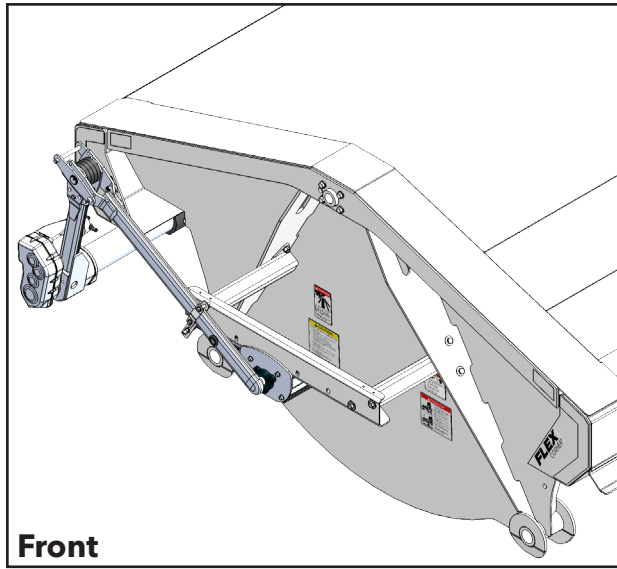

Mounting Parts

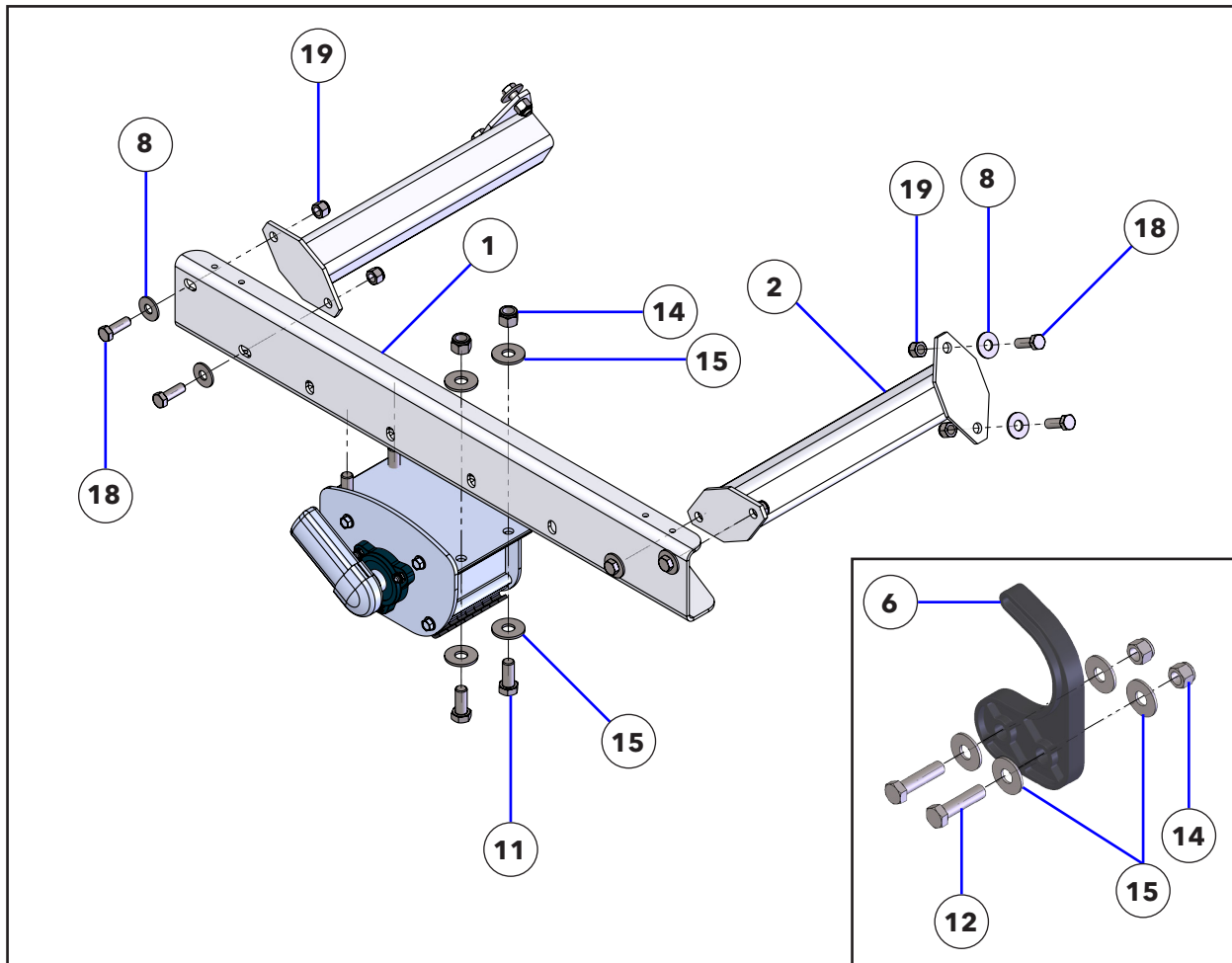

BOM ID	Qty	Item No	Description
1	2	3CAM9385	TARP MOUNTING CHANNEL
2	4	5CAM9038	TARP CHANNEL MOUNT
3	*	5C000008	BRACKET, TARP SUPPORT
4	*	1AUAM9073	SPACER, TARP MOUNTING, 7/8" OD X 11/32" ID X 2" OAL
5	*	1AZAP4108	CLAMP, STEEL CLAMP FOR TARP SECURING ROD PLTD, EA (36830)
6	2	1AZAP4152	TARP HOOK, PLASTIC, ROLLRITE, EA (36840)
7	*	1AFC12FAA05	HEX CAP SCREW, 3/8"-16 X 1", GR 5, PLTD
8	16	1AF009H0000	WASHER, FLAT, 1/2", PLTD
9	*	1AFBP3588	HEX CAP SCREW, 1/4"-20 X 3", GR 8, PLTD
10	*	1AFC18D0000	NUT, HEX LOCK, 1/4"-20, NYLOCK, PLTD
11	4	1AFC12JAAH5	HEX CAP SCREW, 5/8"-11 X 1-1/2", GR 5, PLTD
12	4	1AFC12JBAH5	HEX CAP SCREW, 5/8"-11 X 2-1/2", GR 5, PLTD
13	*	1AFC08E0000	NUT, HEX SERRATED FLANGE, 5/16"-18, PLTD
14	12	1AFC18J0000	NUT, HEX LOCK, 5/8"-11, NYLOCK, PLTD
15	16	1AF009J0000	WASHER, FLAT, 5/8", PLTD
16	*	1AFBP3612	NUT, HEX LOCK, 3/8"-16, TOP LOCK, PLTD
17	*	1AFC37E00L0	HEX CAP SCREW, 5/16"-18 X 3/4", SERRATED FLANGE HD, PLTD
18	16	1AFC12HAAH8	HEX CAP SCREW, 1/2"-13 X 1-1/2" GR 8, PLTD
19	16	1AFC18H0000	NUT, HEX LOCK, 1/2"-13, NYLOCK, PLTD

* Quantities vary by tub length.

ELECTRIC TARP OPTION -- ROLL-RITE

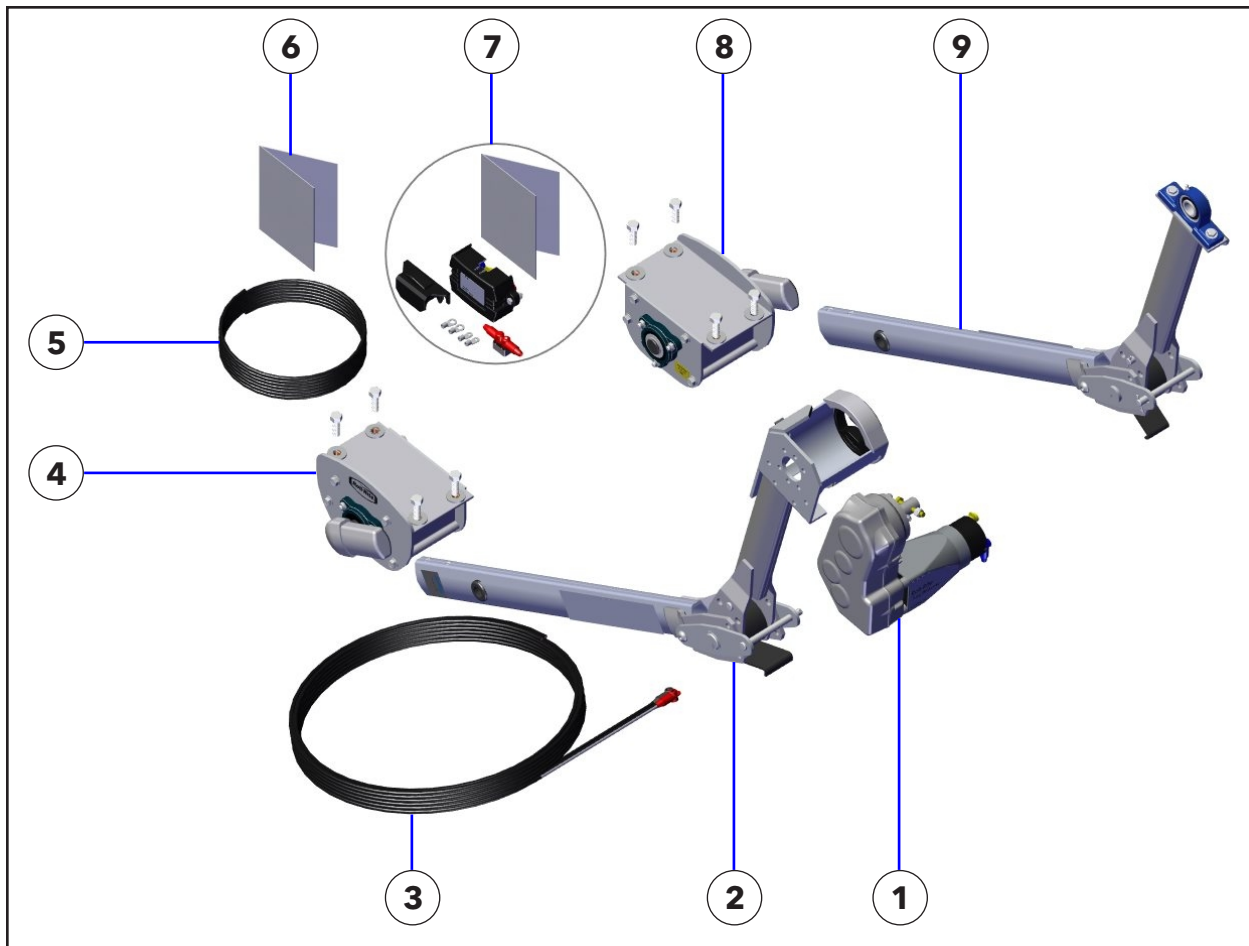

1AZAP3576 (Rite-Lock Power Arm Kit, Pass. Side Stowing for Side Dump 12VTS)			
BOM ID	Qty	Item No	Description
1	1	1AZAP4293	MOTOR, ROLL RITE TARP (10200)
2	1	-	PIVOT, ASSY FRONT 4-SPRING KNUCKLE ARM, MOTOR END (46802)
3	1	1AEW000WF62	PARALLEL BAT CABLE, 6GA, BLK W/RED (11330)
4	1	-	PIVOT, UB ASSEMBLED STS 8-SPR FRONT (102354)
5	1	1AZAP4295	CABLE, 16GA / 3COND, BLU/YEL/RED, 15' (11411)
6	1	-	INSTRUCTIONS, UNIVERSAL STS DUMP SYSTEM (102317)
7	1	1AZ00103460	ELECTRIC KIT, TSCM W/ SS GEN1+ RELAY & ROCKER SW, 6GA (103460)
8	1	-	PIVOT, UB ASSEMBLED STS 8-SPR REAR (102353)
9	1	-	PIVOT, ASSY REAR KNUCKLE ARM, NON-MOTOR END (46803)

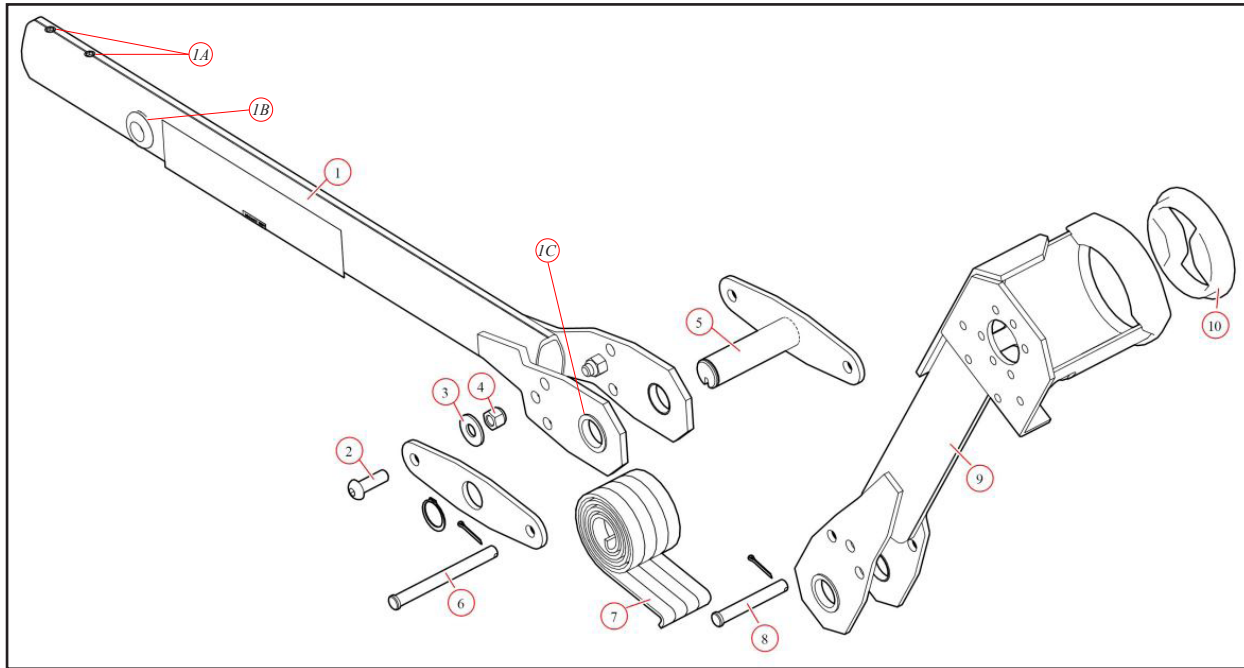

Pivot, Assy Front 4-Spring Knuckle Arm, Motor End (46802)

BOM ID	Qty	Item No	Description
* 1	1	-	PIVOT TUBE, BASE W/SIDE PLATES, 4 SPRING STS KNUCKLES (102199)
1A	1	-	SCREW, 1/2" X 5/8" SET (18291)
1B	1	-	GROMMET, RUBBER 7/8 ID X 1/8 GROOVE FOR TOP MT PIVOTS (16419)
1C	1	-	BUSHING, 1-1/4 POLY T-BUSHING FOR PIVOT PIN (47040)
2	2	-	BOLT, 1/2" X 1-1/2" BUTTON HEAD PLTD (18295)
3	2	1AF009H0000	WASHER, 1/2" FLAT PLTD (18412)
4	2	1AFC18H0000	NUT, 1/2" NYLOCK NUT PLTD (18631)
5	1	-	BRACKET, 4-SP KNUCKLE W/STOP PLATE FOR STS MOTOR END (47970)
6	1	-	PIN, 1/2" X 5-1/4" CLEVIS (18540)
7	4	1AZAP4589	SPRING, SPIRAL TORSION 1-1/4" (47230)
8	1	1AFAP4507	PIN, 1/2" X 3-1/2" CLEVIS (18520)
9	1	-	PIVOT TUBE, FRONT UPPER FOR 4-SP KNUCK W/BUSH 13.06" (102197)
10	1	1AZAP4539	BUSHING, AXLE STABILIZER FOR 4" AXLE (37580)

* Note: All High Capacity Kits require longer lower tarp arms see page 66 for High Capacity specific tarp parts.

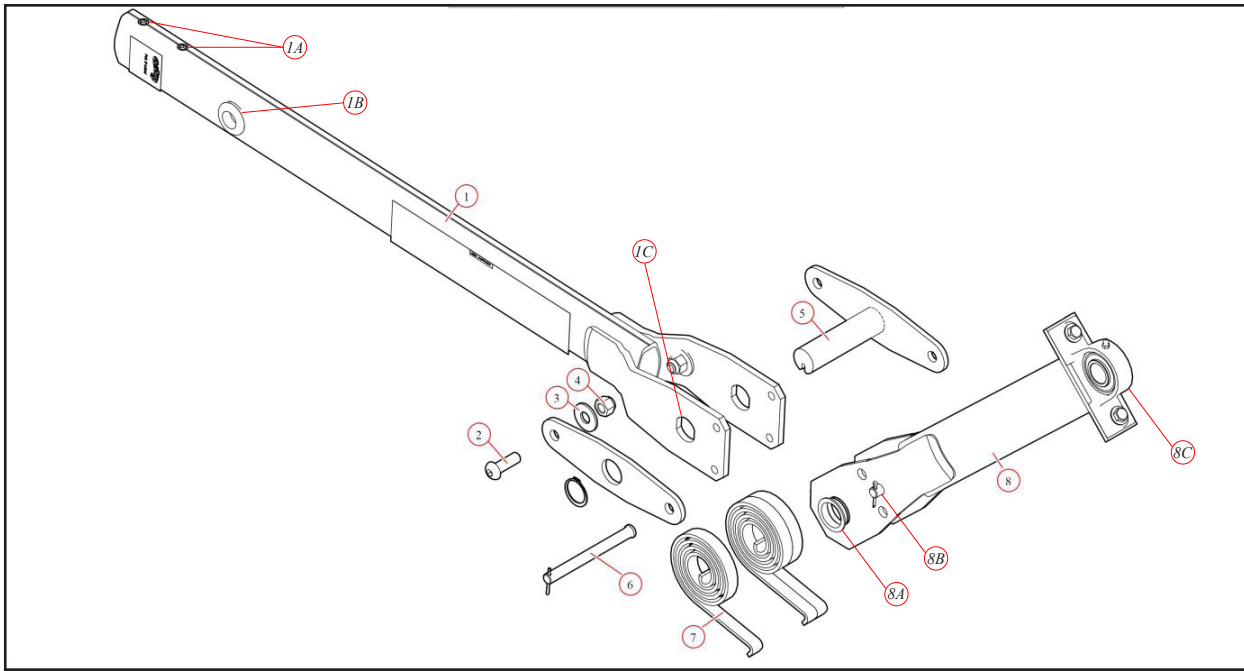

Pivot, Assy Rear Knuckle Arm, Non-Motor End (46803)

BOM ID	Qty	Item No	Description
* 1	1	-	PIVOT TUBE, BASE W/SIDE PLATES, 4-SPRING STS KNUCKLES (102199)
1A	1	-	SCREW, 1/2" X 5/8" SET (18291)
1B	1	-	GROMMET, RUBBER 7/8 ID X 1/8 GROOVE FOR TOP MT PIVOTS (16419)
1C	1	-	BUSHING, 1-1/4 POLY T-BUSHING FOR PIVOT PIN (47040)
2	2	-	BOLT, 1/2" X 1-1/2" BUTTON HEAD PLTD (18295)
3	2	1AF009H0000	WASHER, 1/2" FLAT PLTD (18412)
4	2	1AFC18H0000	NUT, 1/2" NYLOCK NUT PLTD (18631)
5	1	-	BRACKET, 4-SP KNUCKLE W/STOP PLATE FOR STS MOTOR END (47970)
6	1	-	PIN, 1/2" X 5-1/4" CLEVIS (18540)
7	4	1AZAP4589	SPRING, SPIRAL TORSION 1-1/4" (47230)
8	1	-	PIVOT TUBE, REAR UPPER FOR 4-SP KNUCKLE W/BEARING (47890)
8A	1	-	BUSHING, 1-1/4 POLY T-BUSHING FOR PIVOT PIN (47040)
8B	1	1AFAP4507	PIN, 1/2" X 3-1/2" CLEVIS (18520)
8C	1	1AZ31050000	BEARING, PILLOW BLOCK (31055)

* Note: All High Capacity Kits require longer lower tarp arms see page 66 for High Capacity specific tarp parts.

Pivot, UB Assembled STS 8-Spr Front (102354)			
BOM ID	Qty	Item No	Description
1	1	-	PIVOT PIN, FOR 8-SPR ROLLER BEARING PIV, DRIVER SIDE (47400)
2	2	-	BEARING, CARRIER UNDERBODY FLANGED (47800)
2A	3	1AFC18F0000	NUT, 3/8" NYLOCK NUT PLTD (18628)
2B	3	1AFBP3633	BOLT, 3/8-16 X 1-1/8", BUTTON HEAD, PLTD (18242)
3	8	1AZAP4589	SPRING, SPIRAL TORSION 1-1/4" (47230)
4	8	1AFC37FAAH5	BOLT, 3/8 X 1-1/2", THREAD-CUTTING SCREW, HEX WASHER HD (18120)
5	1	-	PLATE, AL FRONT FOR EXT BOLT FLANGE MOUNT UB BOX (102349)
6	1	-	BRACKET, EXT BODY WITH HOLES FOR 8-SPR UB BOX (102269)
7	1	-	PLATE, AL BACK FOR EXT BOLT FLANGE MOUNT UB BOX (102259)

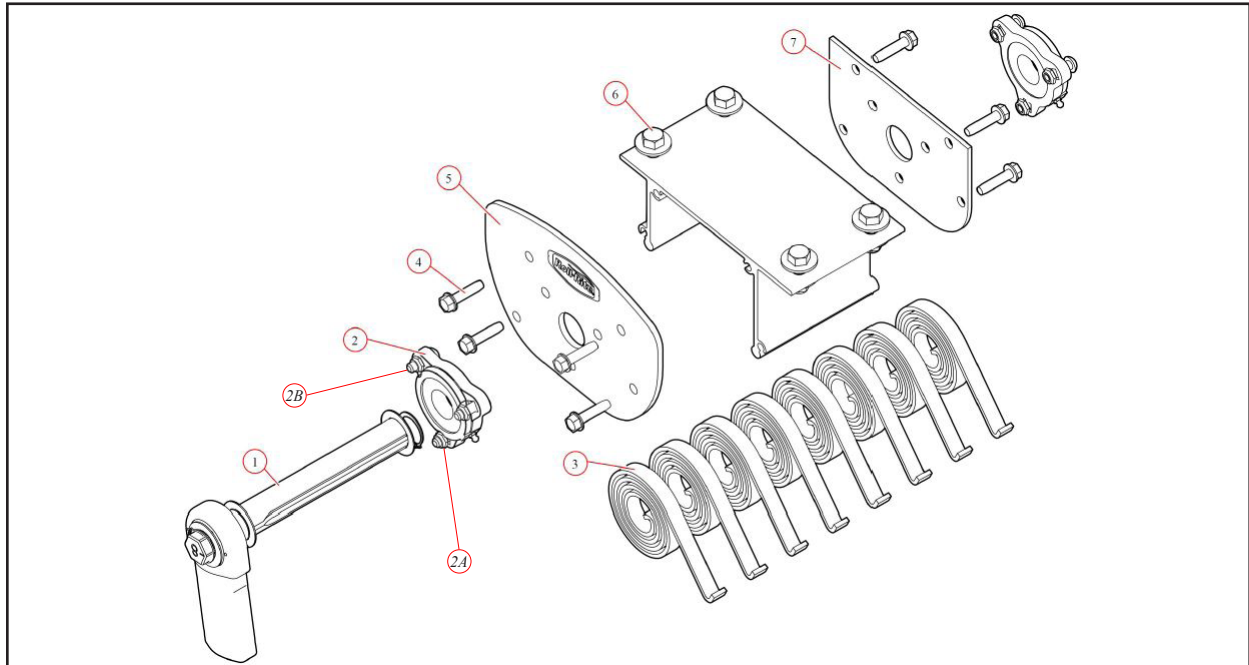

Pivot, UB Assembled STS 8-Spr Rear (102353)			
BOM ID	Qty	Item No	Description
1	1	-	PIVOT PIN, FOR 8-SPR ROLLER BEARING PIV, PASS SIDE (47410)
2	2	-	BEARING, CARRIER UNDERBODY FLANGED (47800)
2A	3	1AFC18F0000	NUT, 3/8" NYLOCK NUT PLTD (18628)
2B	3	1AFBP3633	BOLT, 3/8-16 X 1-1/8", BUTTON HEAD, PLTD (18242)
3	8	1AZAP4589	SPRING, SPIRAL TORSION 1-1/4" (47230)
4	8	1AFC37FAAH5	BOLT, 3/8 X 1-1/2", THREAD-CUTTING SCREW, HEX WASHER HD (18120)
5	1	-	PLATE, AL FRONT FOR EXT BOLT FLANGE MOUNT UB BOX (102349)
6	1	-	BRACKET, EXT BODY WITH HOLES FOR 8-SPR UB BOX (102269)
7	1	-	PLATE, AL BACK FOR EXT BOLT FLANGE MOUNT UB BOX (102259)

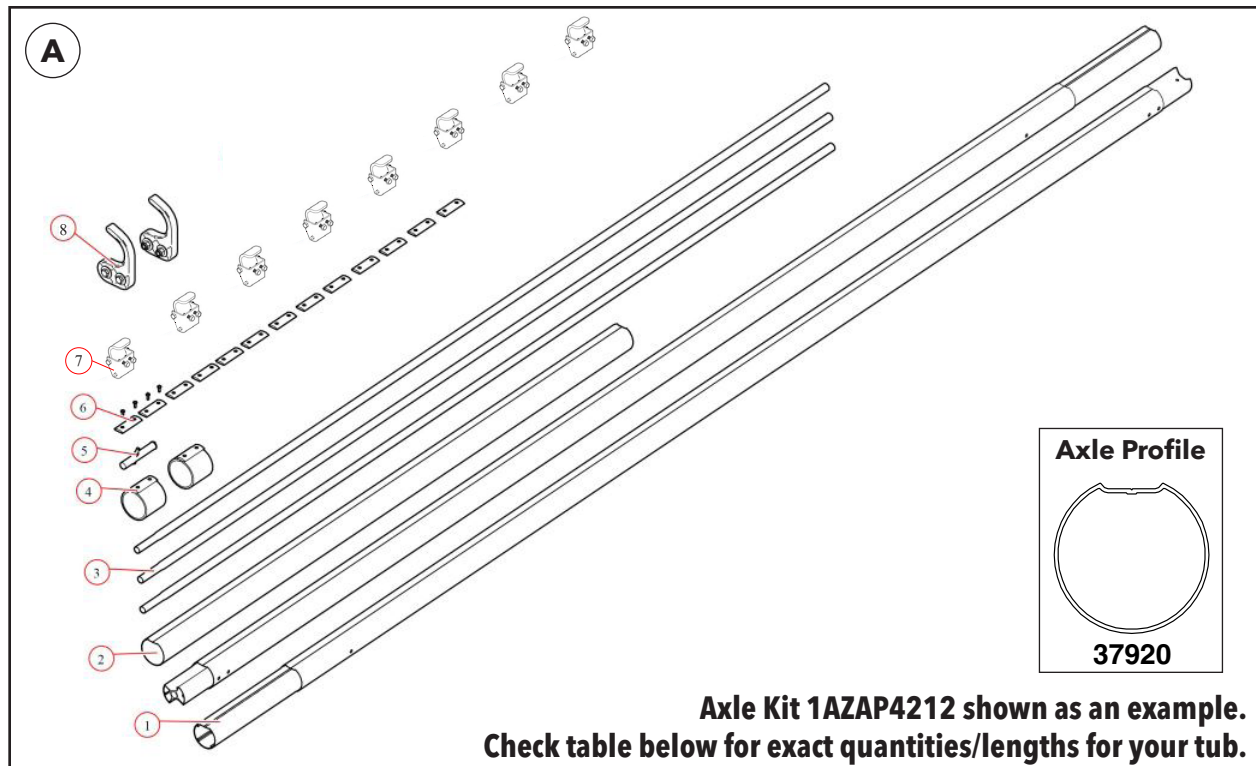

Ⓐ	Ⓐ	① + ②	③	⑥	⑦
Tub Length	Axle Kit Item No	Axle Tube Length	Fixed Tarp Rod Length	Axle Tarp Clips (C/C)	Tarp Rod Clamps (1AZAP4108)
14'	1AZAP4279	17' - 2 1/2"	13' - 8 1/4"	6 (32")	6
15'	1AZAP4279	18' - 2 1/2"	14' - 8 1/4"	6 (34")	6
16'	1AZAP4279	19' - 3"	15' - 8 3/4"	6 (36")	6
17'	1AZAP4459	20' - 2 1/2"	16' - 8 1/4"	6 (38")	6
20'	1AZAP4459	23' - 3"	19' - 9 1/4"	7 (38")	6
24'	1AZAP4410	27' - 3"	23' - 9"	10 (32")	6
30'	1AZAP4212	33' - 6"	30' - 0 3/8"	11 (36")	8
34'	1AZAP4212	37' - 6"	34' - 0 1/2"	11 (40")	8
37'	1AZAP4563	40' - 3"	36' - 9 1/4"	11 (44")	8

BOM ID	Qty	Item No	Description
1		-	AXLE, 4" UNIVERSAL FRONT/REAR SECTION FOR SIDE DUMP (37920)
2		-	EXTRUSION, 4" AXLE, 98" (102367)
3		-	STEEL TUBING, 1.125D X 16GA X 12' RND GALV W/SWEDGE (101815)
4	2	-	AXLE SLEEVE, SIDE DUMP BELT STYLE, AXLE SLEEVE KIT (102379)
5	1	-	HARDWARE, STUB SHAFT KIT FOR SIDE DUMP SYSTEM (102365)
6		-	CLIP, TARP CLIP W/HARDWARE FOR STS AXLE (37830)
7		1AZAP4108	CLAMP, STEEL CLAMP FOR TARP SECURING ROD PLTD, EA (36830)
8	2	1AZAP4152	TARP HOOK , PLASTIC, ROLLRITE, EA (36840)

Tub Length	Tarp Kit	Mesh Tarp	Tarp Size
14'	1AZAP3576	1AZAP4598	13'-6" x 162"
15'	1AZAP3576	1AZAP4599	14'-6" x 162"
16'	1AZAP3576	1AZAP4600	15'-6" x 162"
17'	1AZAP3576	1AZAP4601	16'-6" x 162"
20'	1AZAP3576	1AZAP4602	19'-7" x 162"
24'	1AZAP3576	1AZJ23800RE	23'-8" x 162"
30'	1AZAP3576	1AZAP4603	29'-10" x 162"
34'	1AZAP3576	1AZAP4604	33'-10" x 162"
37'	1AZAP3576	1AZAP4605	36'-7" x 162"

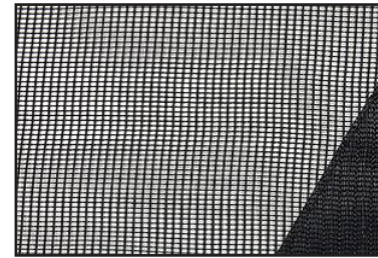

Mesh Tarp

Roll-Rite Electric Tarp Parts for High-Capacity Kits Only

Tub Length	Axle Kit	Tarp Kit	Mesh Tarp	Tarp Size	Axle Tube Length	Fixed Tarp Rod Length
20' H.C.	1AZAP4459	1AZAP4402	-	20' x 147"	23' - 3"	20' - 1 3/4"
24' H.C.	1AZAP4410	1AZAP4402	1AZAP4409	24' x 147"	27' - 3"	24' - 1 1/2"
34' H.C.	1AZAP4212	1AZAP4402	1AZAP3950	34' x 147"	37' - 6"	34' - 4 3/4"
37' H.C.	1AZAP4563	1AZAP4402	1AZAP4562	37' x 147"	40' - 3"	37' - 1 3/4"

Note: All High Capacity Kits, including XL Kits, use the same quantity and spacing of Axle Tarp Clips and Tarp Rod Clamps as standard tubs. Longer lower tarp arms are required for all High Capacity Kits - use Item Number 1AZ102266RE (ROLL-RITE HIGH CAPACITY TARP ARM, EA, #102266).

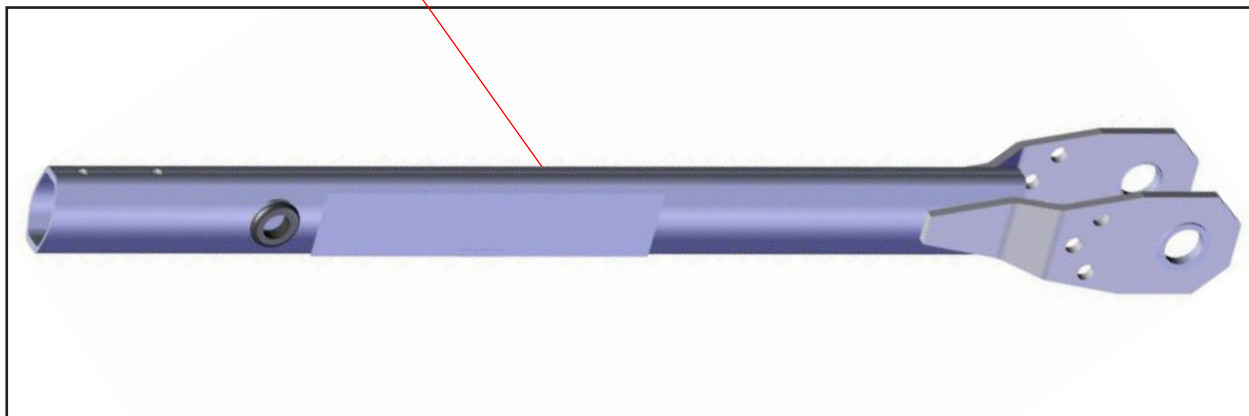

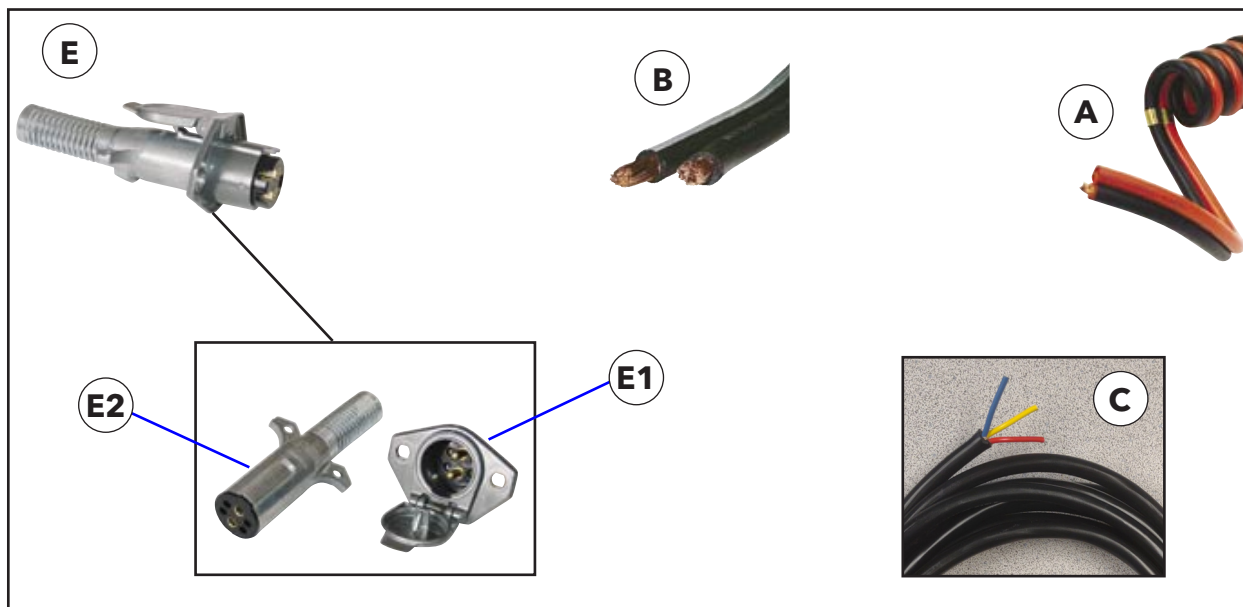
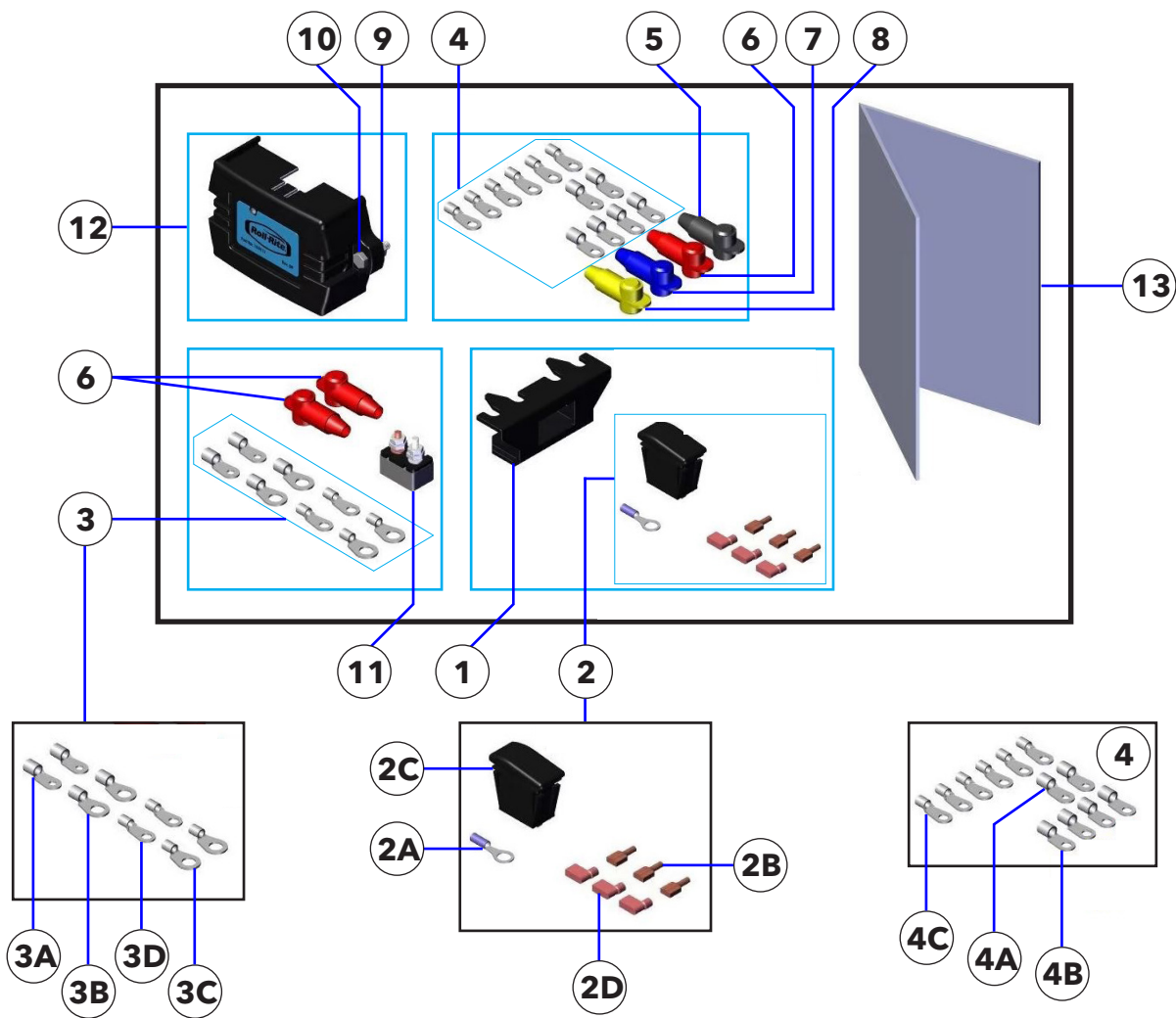

1AZ00103460 (Electric Kit, TSCM W/SS Gen1+ Relay & Rocker Switch, 6GA)			
BOM ID	Qty	Item No	Description
1	1	1AZ00010390	MOUNT BRACKET, ROCKER SWITCH (10390)
2	1	-	ROCKER SWITCH KIT (10915)
2A	1	1AEC0031506	TERMINAL, 14 GA INSULATED, 3/8" RING (16080)
2B	3	-	TERMINAL, 18 GA INSULATED, Q.D. FEMALE (16118)
2C	1	1AZ00019300	SWITCH, ROCKER (OPEN/CLOSE) (19300)
2D	3	-	TERMINAL, 14-16 GA INSULATED, Q.D. FLAG FEMALE (100460)
3	1	-	TERMINAL KIT FOR CIRC. BREAKER, 6/8 GA TERMINALS (10918)
3A	2	-	TERMINAL, 6 GA, #10 RING (16020)
3B	2	1AEC0036073	TERMINAL, 6 GA, 3/8" RING (16030)
3C	2	-	TERMINAL, 8 GA, 3/8" RING (16150)
3D	2	1AEC0033002	TERMINAL, 8 GA, 1/4" RING (16155)
4	1	-	TERMINAL KIT FOR SS RELAY, 6/8 GA TERMINALS (10919)
4A	2	-	TERMINAL, 6 GA, #10 RING (16020)
4B	4	1AEC0036071	TERMINAL, 6 GA, 1/4" RING (16021)
4C	6	1AEC0033002	TERMINAL, 8 GA, 1/4" RING (16155)
5	1	-	TERMINAL BOOT, BLACK, 8-2GA (16200)
6	3	-	TERMINAL BOOT, RED, 8-2GA (16201)
7	1	-	TERMINAL BOOT, BLUE, 8-2GA (16202)
8	1	-	TERMINAL BOOT, YELLOW, 8-2GA (16203)
9	2	1AFC08D0000	HEX NUT, 1/4-20 FLANGE, SERRATED, PLTD (18620)
10	2	1AFC12DAA05	HEX BOLT, 1/4-20 X 1", GR5, PLTD (18700)
11	1	1AZ00101259	50A MANUAL RESET CIRCUIT BREAKER, RITE TOUCH (101259)
12	1	1AZ00103238	12V RITE TOUCH RELAY SS GEN1+ W/HOUSING (103238)
13	-	-	ELECTRICAL COMPONENT INSTALLATION GUIDE (105568)

TO ADD TARP CONTROLS TO A SECOND TRACTOR FOR A STANDARD HYDRAULIC SIDE DUMP, SEE YOUR DEALER FOR COMPLETE KIT AND PRICING FOR 4CFK2014 (KIT, ROLL-RITE TARP, CONTROL SWITCH FOR 2ND TRACTOR). FOR EOH TRAILERS, SEE PAGE 43.

Other Electrical Components for Roll-Rite Tarps			
BOM ID	Qty	Item No	Description
A	-	1AZ00011320	6GA DUAL COILED CORD (11320)
B	-	1AEW000WF62	PARALLEL BAT CABLE, 6GA, BLK W/RED (11330)
C	-	1AZAP4295	CABLE, 16GA / 3COND, BLU/YEL/RED, 15' (11411)
E	-	1AZAP4211	MALE & FEMALE PLUG SET, 2-PIN, ROLL-RITE TARP (12760)
E1	1	1AZAP4236	FEMALE PLUG, 2-PIN, ROLL-RITE TARP (12770)
E2	1	1AZAP4235	MALE PLUG, 2-PIN, ROLL-RITE TARP (12780)

**Roll-Rite Generation 1+ Solid State Reversing Relay with Rocker Switch
(Tarp Uncovering to the right of driver)**

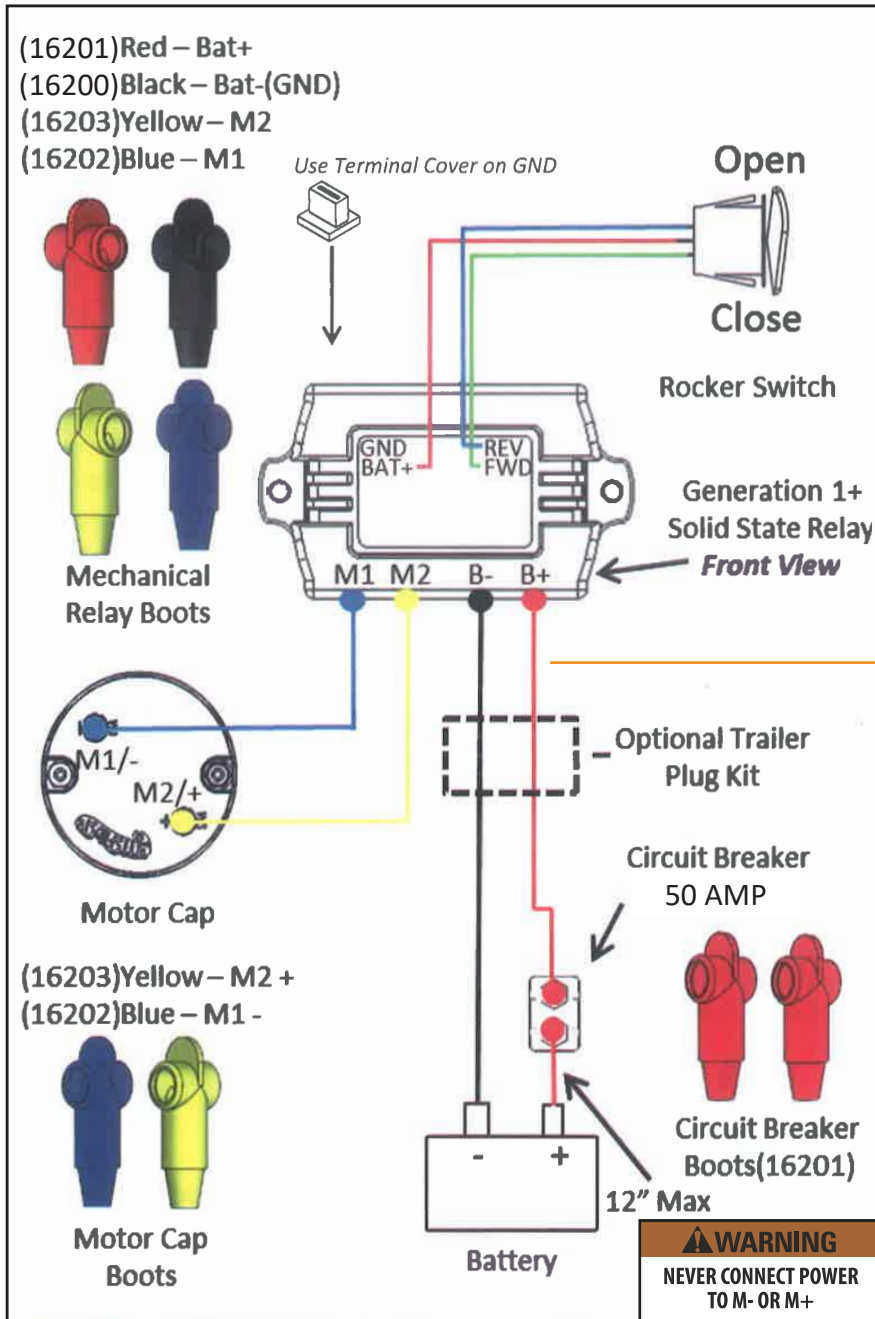

WARNING

Note: After installation, the terminals on the B+ circuit contain un-switched 12V energy at all times. Installation requirements must be followed to avoid contact between these terminals and chassis ground.

Wiring the Tractor

There are two items to wire on the tractor before you can operate your Demco side dump. The control box and the tarp power wire.

To install the control box, find a suitable location in the cab of the tractor and mount the control box. The red and black two wire cable attached to the back of the box is the power wire. Plug the cigarette lighter end into a power connection in the cab.

If you do not have an available outlet for the cigarette lighter end, use the following instructions:

- Cut the cigarette lighter plug off.
- Split apart the wires and connect the red wire to a 12v dc power source and the black to ground.
-  - **Red wire must be positive and Black negative. Reversing these wires can damage the control system.**
- A bag of terminals is included to allow you to tap into most truck fuse panels.

Route the gray cord and male 9 pole plug out of the cab and to the front bulkhead of the side dump. Plug the cord into the female 9 pole socket on the trailer bulkhead. You will now be able to raise and lower the rear axle and dump the tub.

NOTE: Air must be supplied to the side dump for the lift axle to operate properly. Hydraulic oil must be supplied to the side dump to dump the tub.

To use the tarp you will need to supply 12 volt power to the side dump to operate the tarp motor. Due to the large power draw of the tarp motor, the electrical supply must be hooked directly to the battery and the heavy #6 wire included with the kit must be used.

Refer to the Roll Rite wiring diagram for reference. The relay has been already mounted on the side dump and the momentary switch that rolls/unrolls the tarp is in the control box installed previously. All that needs to be done is to run a wire from the battery to the female two pole socket on the road side front corner of the side dump.

Locate the circuit breaker as close to the positive battery post as possible. If the circuit breaker is not mounted to the battery box or truck frame, make sure that the terminals cannot touch anything that would create a short circuit. See image on next page for installation orientation of circuit breaker.

Separate enough of the white wire on the #6 white/black cord to reach from the positive battery terminal to the circuit breaker. Cut off the white wire. Strip the white wire and crimp on ring terminals to match the battery cable bolt and the post on the circuit breaker.



Do not hook the white wire to the battery until everything else is wired.

Crimp a ring terminal on the white wire on the remaining white/black cord and attach it to the circuit breaker.

Crimp a ring terminal on the black wire and attach it to the negative battery post.

Route the white/black cord to the female socket on the side dump. Cut the cord and strip the ends back to slip into the terminals on the back of the male 2 pin plug. Match the white and black wires to the corresponding wires in the side dump socket. You may need to slip the cover off the back of the socket to make sure that the wires match up. Secure the white/black cord to the truck frame.

Hook the white wire to the battery.

The tarp will now operate from the control box. It is best to have the tractor running while operating the tarp.

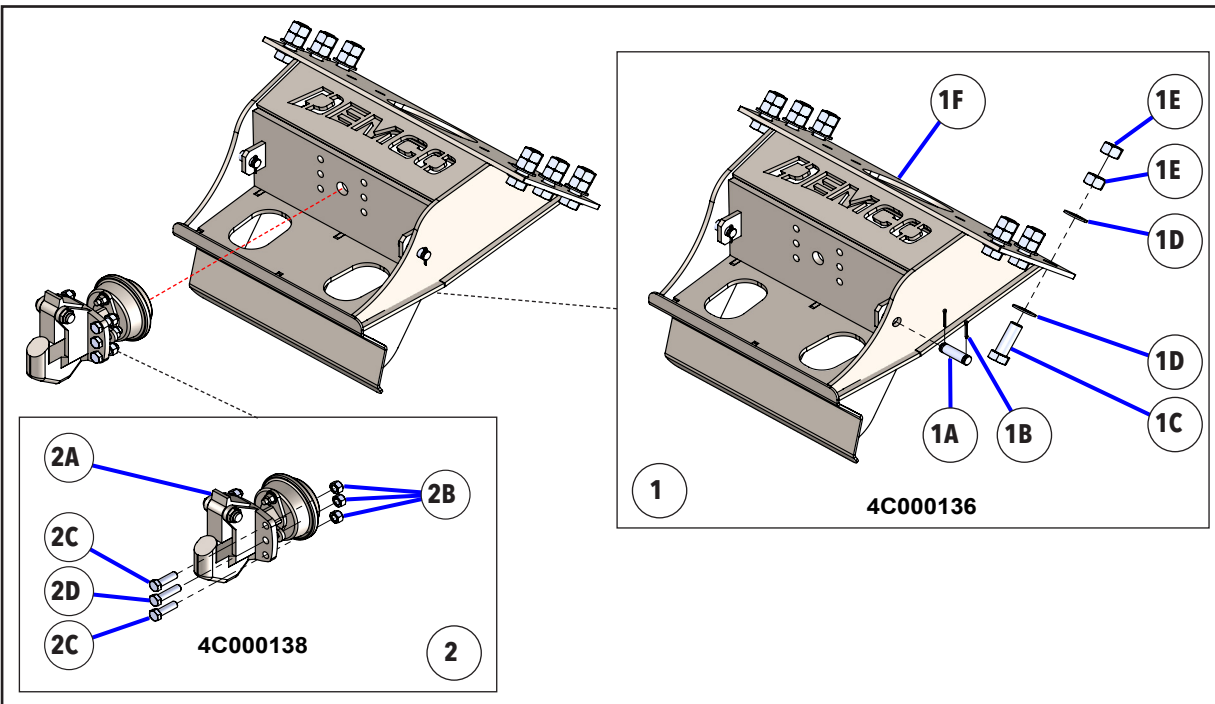

BOM ID	Qty	Item No	Description
1	1	4C000136	PUSH BLOCK PINTLE HITCH COMPLETE W/ HARDWARE
1A	2	1AFBP3403	PIN, CLEVIS, 1 X 2-3/4 USEABLE
1B	4	1AFBP3511	PIN, COTTER, 3/16 X 1-3/4
1C	6	1AFC12SDAH8	BOLT, 1-1/4-7 X 4", GRD 8, YZ
1D	12	1AFBP3634	WASHER, FLAT, 1-1/4, SAE, ZINC PLTD
1E	12	1AFBP3720	NUT, HEX, 1-1/4" - 7, GRD 8, YZ
1F	1	5C000189	PUSH BLOCK PINTLE HITCH
2	1	4C000138	PINTLE HOOK ASSY, COMPLETE W/ HARDWARE
2A	1	1ACAP3644	PINTLE HOOK ASSY W/ AIR LOCK, PREMIER 2300A
2B	6	1AFBP3442	NUT, HEX LOCK, 3/4"-10, TOP LOCK, GRD C, PLTD
2C	4	1AFBP3197	HEX CAP SCREW, 3/4"-10 X 2-1/2", GRD 8, PLTD
2D	2	1AFBP3209	HEX CAP SCREW, 3/4"-10 X 3, GRD 8, PLTD

4C000137 (PINTLE HITCH STUB BUMPER COMPLETE)			
BOM ID	Qty	Item No	Description
1	6	1AF009L000	3/4 USS FLAT WASHER ZINC PLTD
2	6	1AFBP3139	HEX CAP SCREW, 3/4"-10 X 2", GRD 5, ZINC PLTD
3	6	1AFBP3296	NYLON INSERT LOCKNUT, 3/4-10 UNC
4	2.04	1AQAS000000	RWR CONSPICUITY TAPE
5	2	1AR00000050	4X4X3/16 PLASTIC TUBE CAP
6	1	5C000191	PINTLE HITCH STUB BUMPER

***THIS STUB BUMPER IS SPECIFIC TO THE PINTLE HITCH/PUSH BLOCK COMBO**

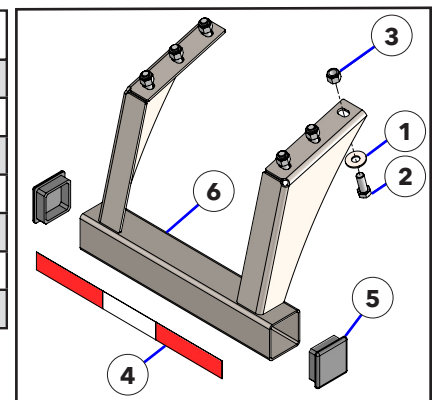

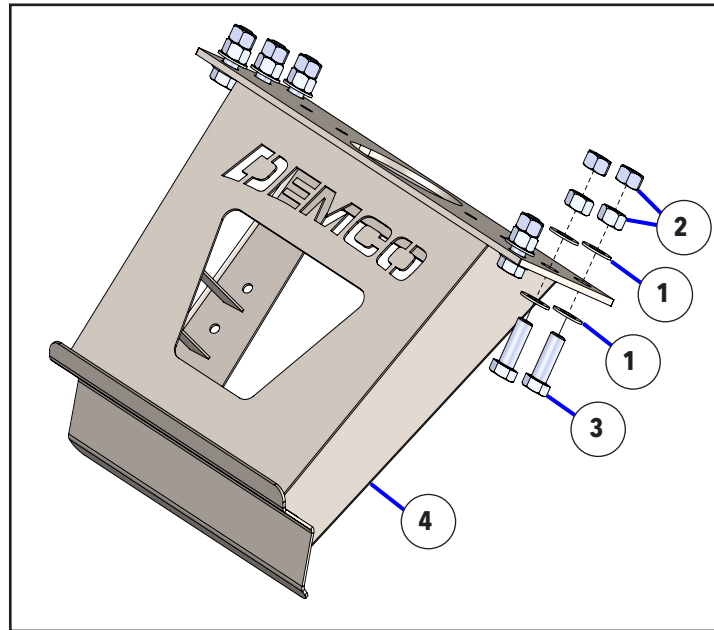

4C000117 (PUSH BLOCK W/ LOGO, COMPLETE W/ HARDWARE)			
BOM ID	Qty	Item No	Description
1	12	1AFBP3634	WASHER, FLAT, 1-1/4, SAE, ZINC PLTD
2	12	1AFBP3720	NUT, HEX, 1-1/4"-7, GRD 8, YZ
3	6	1AFC12SDAH8	BOLT, 1-1/4-7 X 4", GRD 8, YZ
4	1	5C000172	PUSH BLOCK W/ DEMCO LOGO

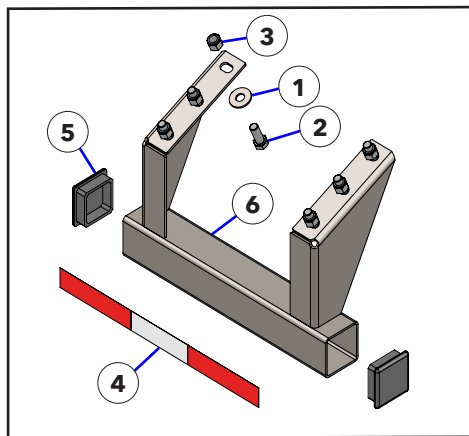

4C000116 (STUB BUMPER, COMPLETE W/ END CAPS & HARDWARE)			
BOM ID	Qty	Item No	Description
1	6	1AF009L000	3/4 USS FLAT WASHER ZINC PLTD
2	6	1AFBP3139	HEX CAP SCREW, 3/4"-10 X 2", GRD 5, ZINC PLTD
3	6	1AFBP3296	NYLON INSERT LOCKNUT, 3/4-10 UNC
4	2.04	1AQAS000000	RWR CONSPICUITY TAPE
5	2	1AR00000050	4X4X3/16 PLASTIC TUBE CAP
6	1	5C000173	PINTLE HITCH STUB BUMPER

***THIS STUB BUMPER IS SPECIFIC TO THE PUSH BLOCK OPTION**

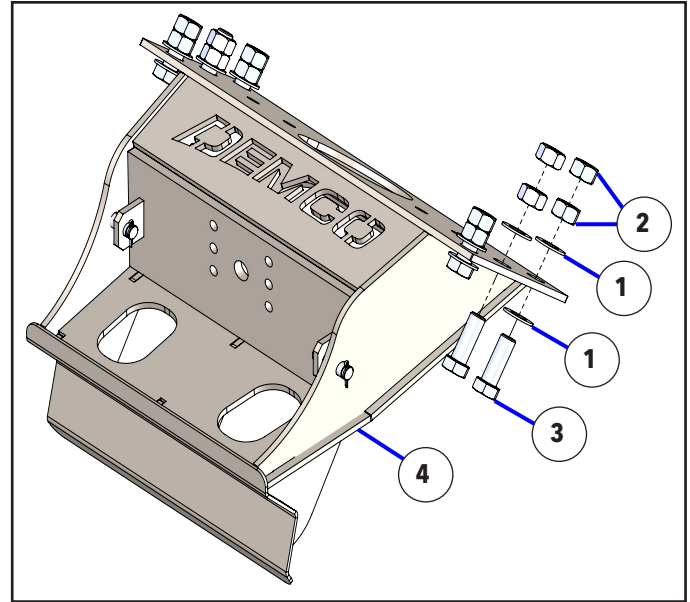
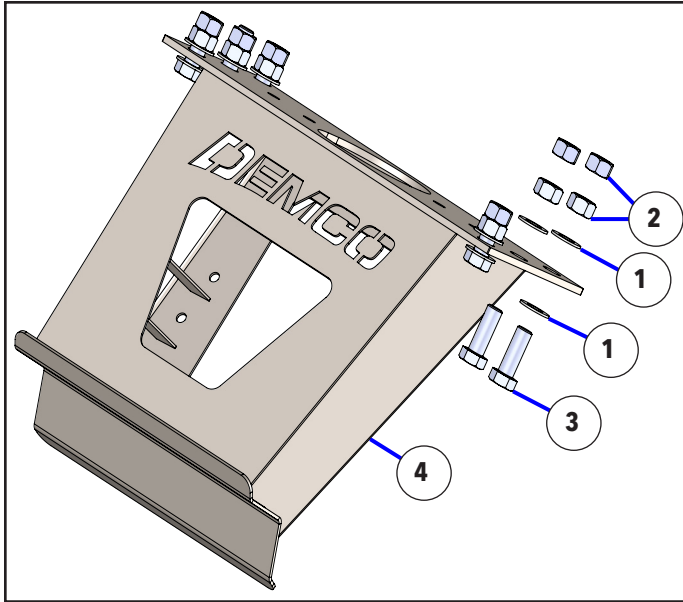

4C000119 (PUSH BLOCK W/ LOGO, COMPLETE FOR UR BUMPER)			
BOM ID	Qty	Item No	Description
1	10	1AFBP3634	WASHER, FLAT, 1-1/4, SAE, PLTD
2	12	1AFBP3720	NUT, HEX, 1-1/4"-7, GRD 8, YZ
3	6	1AFC12SDAH8	BOLT, 1-1/4-7 X 4", GRD 8, YZ
4	1	5C000172	PUSH BLOCK W/ DEMCO LOGO

4C000139 (PUSH BLOCK PINTLE HITCH W/ HARDWARE, UR BUMPER)			
BOM ID	Qty	Item No	Description
1	10	1AFBP3634	WASHER, FLAT, 1-1/4, SAE, PLT
2	12	1AFBP3720	NUT, HEX, 1-1/4"-7, GRD 8, YZ
3	6	1AFC12SDAH8	BOLT, 1-1/4-7 X 4", GRD 8, YZ
4	1	5C000189	PUSH BLOCK W/ DEMCO LOGO

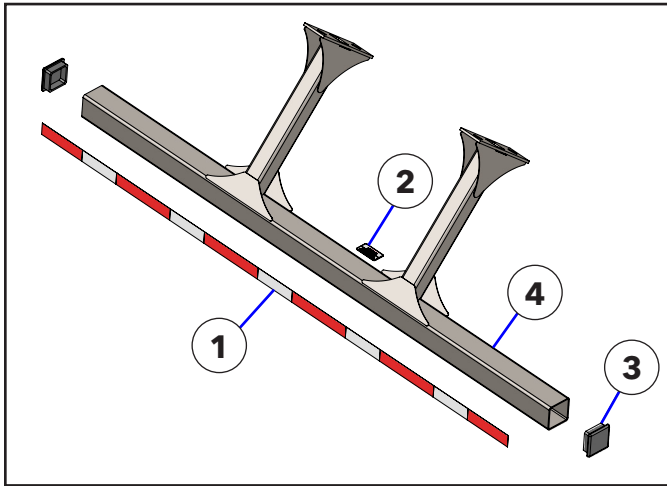

4C000118 (UNDERRIDE BUMPER PROTECTOR, COMPLETE W/O HARDWARE)			
BOM ID	Qty	Item No	Description
1	7.95	1AQAS000000	RWR CONSPICUITY TAPE
2	1	1AQCD065061	ICC BUMPER DECAL
3	2	1AR00000050	4X4X3/16 PLASTIC TUBE CAP
4	1	5CAM8105	UNDERRIDE BUMPER GUARD

UNDERRIDE BUMPER ONLY HARDWARE			
BOM ID	Qty	Item No	Description
1	8	1AFBP3634	WASHER, FLAT, 1-1/4, SAE, PLTD
2	8	1AFBP3720	NUT, HEX, 1-1/4"-7, GRD 8, YZ
3	4	1AFC12SDAH8	BOLT, 1-1/4-7 X 4", GRD 8, YZ

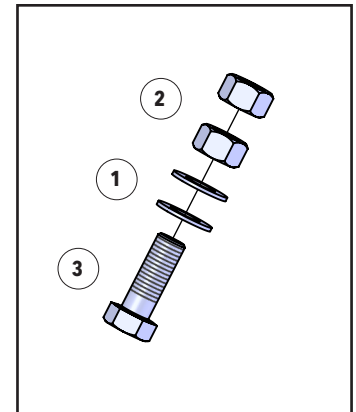

REAR ATTACHMENT OPTIONS

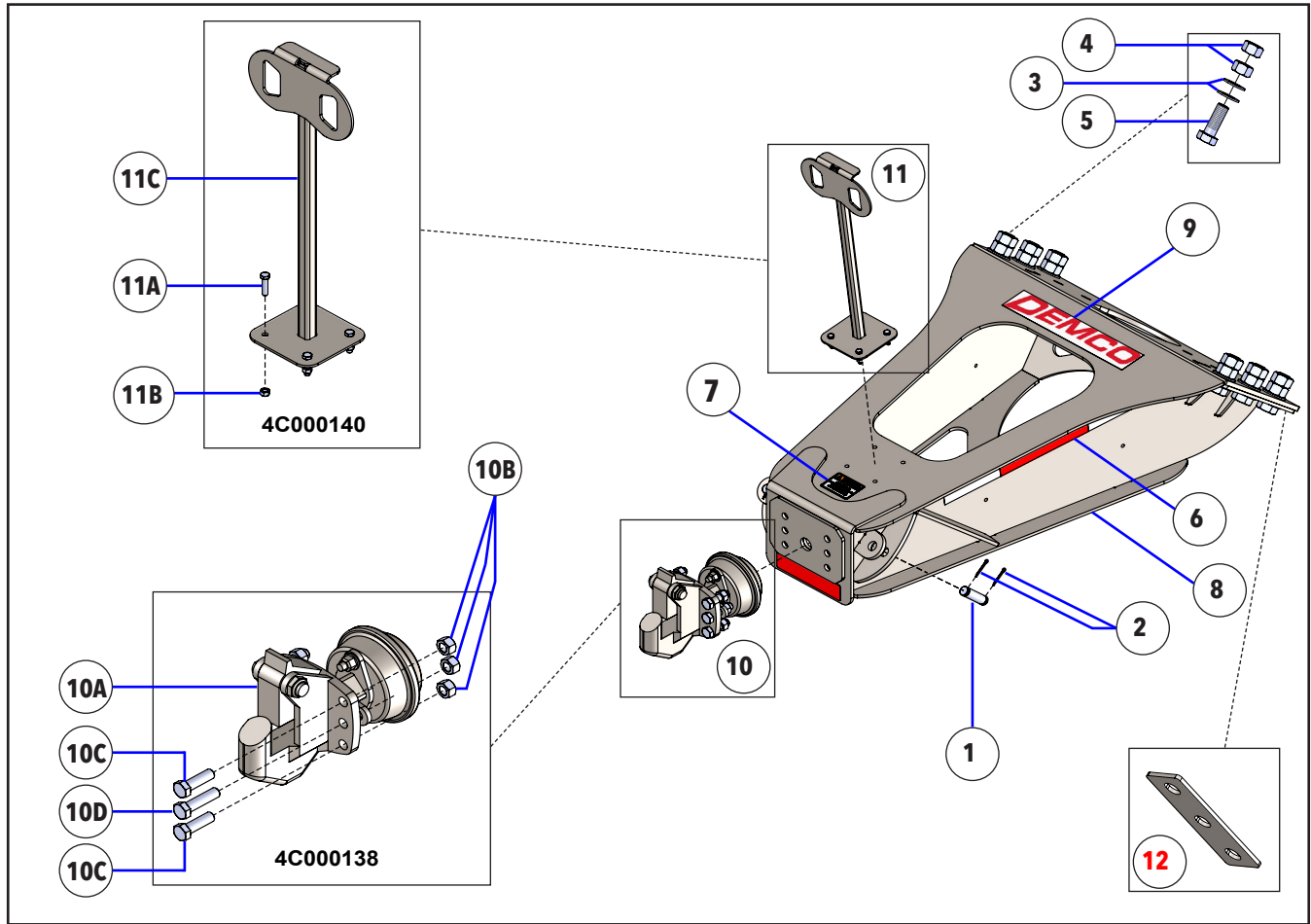

5C000200 (EXTENDED PINTLE HITCH ASSEMBLY)			
BOM ID	Qty	Item No	Description
1	2	1AFBP3403	PIN, CLEVIS, 1 X 2-3/4 USEABLE
2	4	1AFBP3511	PIN, COTTER, 3/16 X 1-3/4
3	10	1AFBP3634	WASHER, FLAT, 1-1/4, SAE, PLTD
4	12	1AFBP3720	NUT, HEX, 1-1/4"-7, GRD 8, YZ
5	6	1AFC12SDAH8	BOLT, 1-1/4-7 X 4", GRD 8, YZ
6	6.58	1AQAS000000	RWR CONSPICUITY TAPE
7	1	1AQWA065076	WARNING - HITCH LOAD HAZARD
8	1	5C000199	MY24 EXTENDED PINTLE HITCH MOUNT
9	1	DE21005	SMALL RED DEMCO DECAL, 17" X 3.125"
10	1	4C000138	PINTLE HOOK ASSY, COMPLETE W/ HARDWARE
10A	1	1ACAP3644	PINTLE HOOK ASSY W/ AIR LOCK, PREMIER 2300A
10B	6	1AFBP3442	NUT, HEX LOCK, 3/4"-10, TOP LOCK, GRD C, PLTD
10C	4	1AFBP3197	HEX CAP SCREW, 3/4"-10 X 2-1/2", GRD 8, PLTD
10D	2	1AFBP3209	HEX CAP SCREW, 3/4"-10 X 3, GRD 8, PLTD
11	1	4C000140	EXTENDED PINTLE HOSE HANGER COMPLETE W/ HARDWARE
11A	4	1AFBP3005	HEX CAP SCREW, 3/8"-16 X 1-1/2", GRD 5, PLTD
11B	4	1AFC17F0000	NUT, HEX, 3/8"-16, GRD 2, PLTD
11C	1	5C000192	EXTENDED PINTLE HOSE HANGER
12*	2	3C000226	MY24 EPH MOUNTING BACKING PLATE

*NOT REQUIRED WHEN MOUNTING WITH UNDERRIDE BUMPER

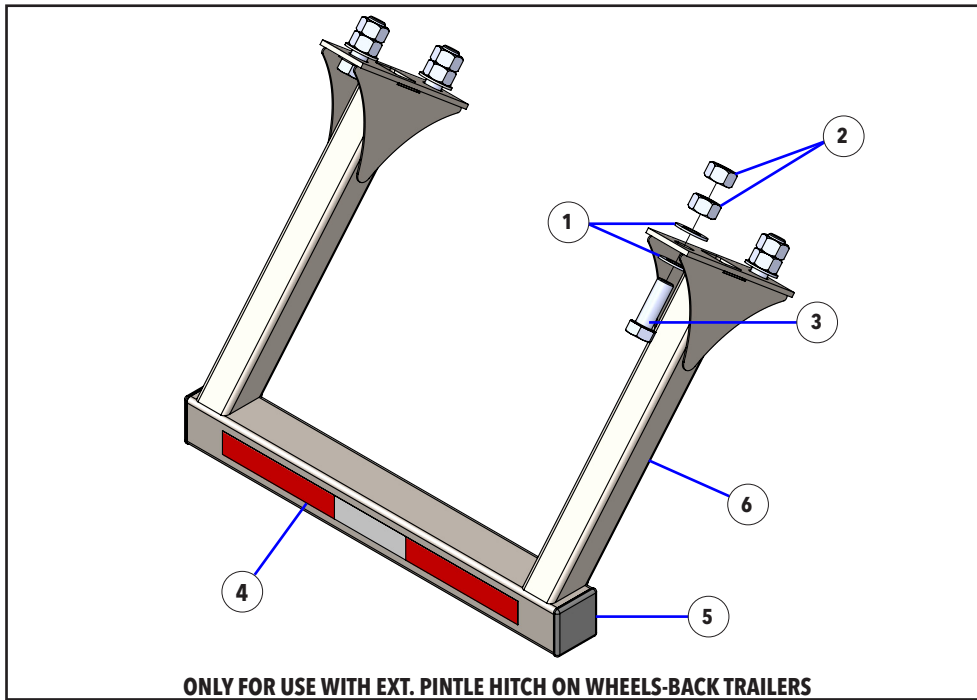

4C000153 (LIGHTWEIGHT BUMPER, COMPLETE FOR EXTENDED PINTLE HITCH)			
BOM ID	Qty	Item No	Description
1	8	1AFBP3634	WASHER, FLAT, 1-1/4, SAE, PLTD
2	8	1AFBP3720	NUT, HEX, 1-1/4"-7, GRD 8, YZ
3	4	1AFC12SDAH8	BOLT, 1-1/4-7 X 4", GRD 8, YZ
4	2.42	1AQAS000000	RWR CONSPICUITY TAPE
5	2	1AR00000050	4X4X3/16 PLASTIC TUBE CAP
6	1	5C000227	MY24 SLIM BUMPER FOR EPH, WELDMENT

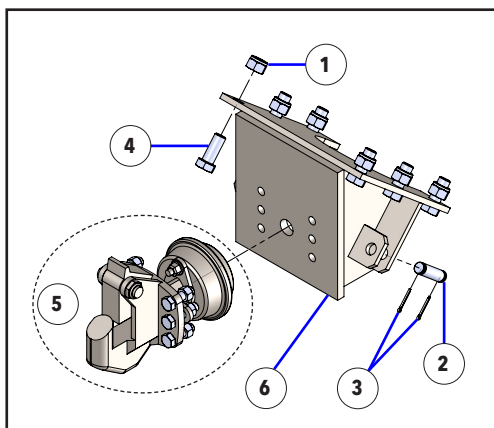

STANDARD PINTLE HITCH MOUNT			
BOM ID	Qty	Item No	Description
1	6	1AFBP3295	NUT, NYLOCK, 1"-8, GRD 8, YZ
2	2	1AFBP3403	PIN, CLEVIS, 1" X 2-3/4" L
3	4	1AFBP3511	PIN, COTTER, 3/16 X 1-3/4
4	6	1AFBP3721	BOLT, 1"-8 X 2-1/2", GRD 8, YZ
5*	1	4C000138	PINTLE HOOK ASSY, COMP.
6	1	5CAM8103	PINTLE HITCH MOUNT

*SEE PREVIOUS PAGE FOR PARTS BREAKDOWN

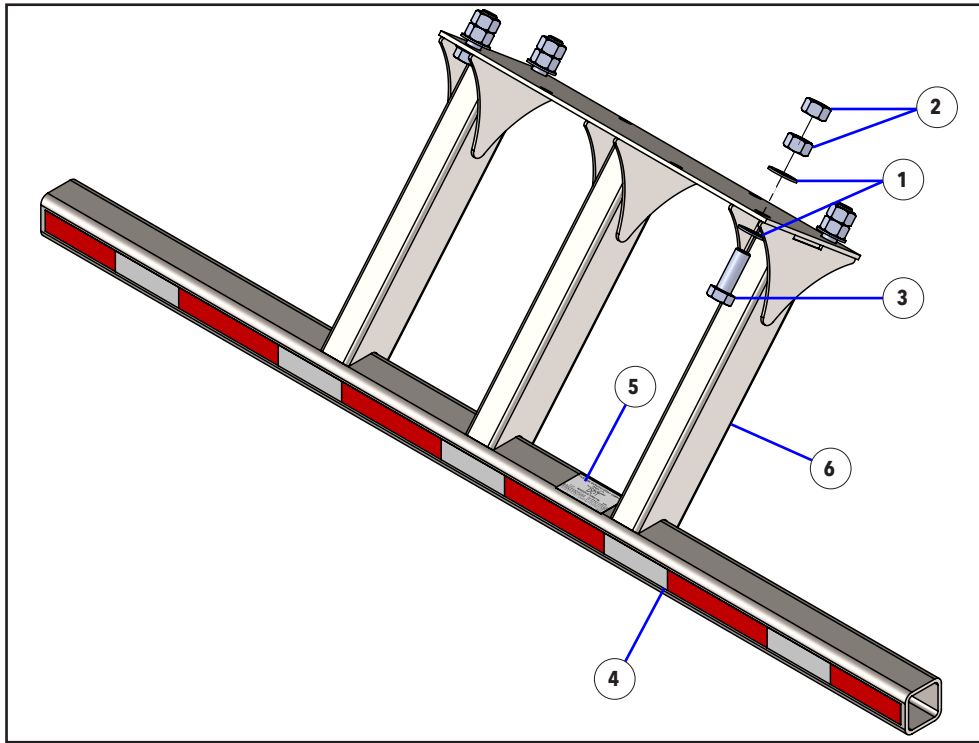

CMVSS UNDERRIDE BUMPER

BOM ID	Qty	Item No	Description
1	8	1AFBP3634	WASHER, FLAT, 1-1/4, SAE, PLTD
2	8	1AFBP3720	NUT, HEX, 1-1/4"-7, GRD 8, YZ
3	4	1AFC12SDAH8	BOLT, 1-1/4-7 X 4", GRD 8, YZ
4	7.95	1AQAS000000	RWR CONSPICUITY TAPE
5	1	1AQCD065061	ICC BUMPER DECAL
6	1	5CAM9343	UNDERRIDE BUMPER GUARD, CMVSS

PUSH BLOCK COMPATIBLE W/ CMVSS BUMPER

BOM ID	Qty	Item No	Description
1	4	1AFBP3295	NUT, NYLOCK, 1"-8, PLTD
2	4	1AFBP3721	BOLT, 1"-8 X 2-1/2", GRD 8, YZ
3	1	5CAM9345	CMVSS BUMPER PUSHBLOCK

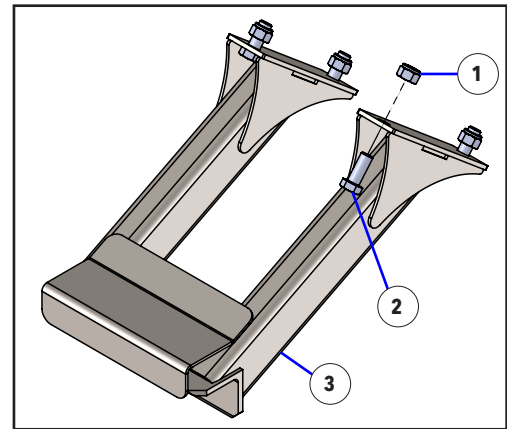

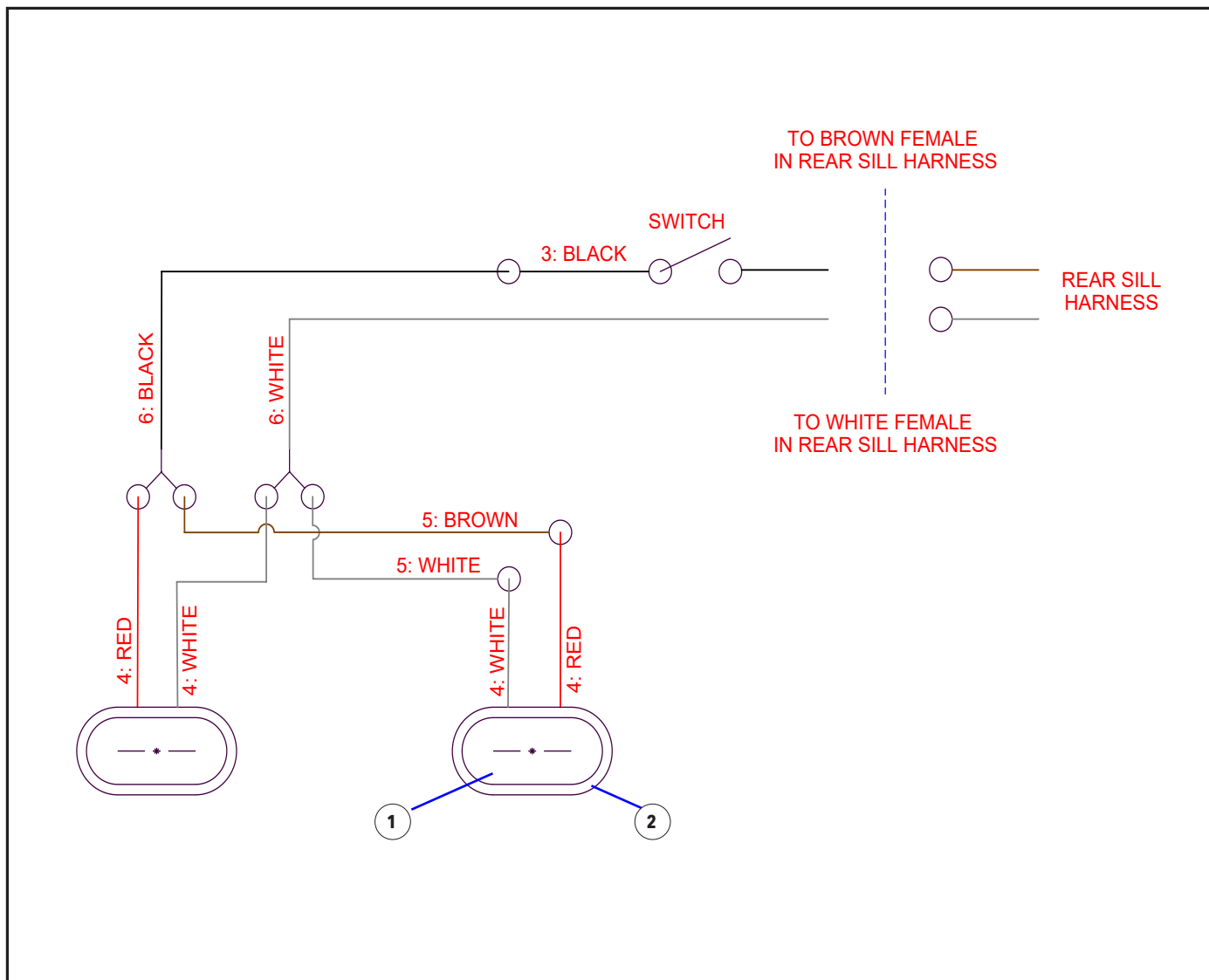

REAR STROBE LIGHT KIT (4C000133)			
BOM ID	Qty	Item No	Description
1	2	1AEL060360Y	6" OVAL AMBER STROBE LIGHT
2	2	1AEL0607003	6" OVAL GROMMET
3	1	1AES0096843	SWITCH, SPST ON-OFF
4	2	1AEX0095500	HARN 8" STROBE LIGHT PLUG WIRE
5	1	1AEX4010060	HARN 60" M/C, 2M .180 BULLETS/2F
6	1	1AEX8834236	HARN 60" M/C, 2M .180 BULLETS/4F

DEMCO

4010 320th St., Boyden, IA. 51234

Phone: (712) 725-2311

Fax: (712) 725-2380

Toll Free: 1-800-54DEMCO (1-800-543-3626)

**Demco warranty policies, operator manuals, and product registration
can be found online:**

www.demco-products.com