



Doing Our Best to Provide You the Best

8C000305 A

02/24

SIDE DUMP

TRI AXLE - AIR RIDE

9CCR443AR603424

44' Chassis, 34' Tub, 60" Spread

9CCR443AR60RL3424

44' Chassis, 34' Tub, 60" Spread w/ Rear Lift Axle

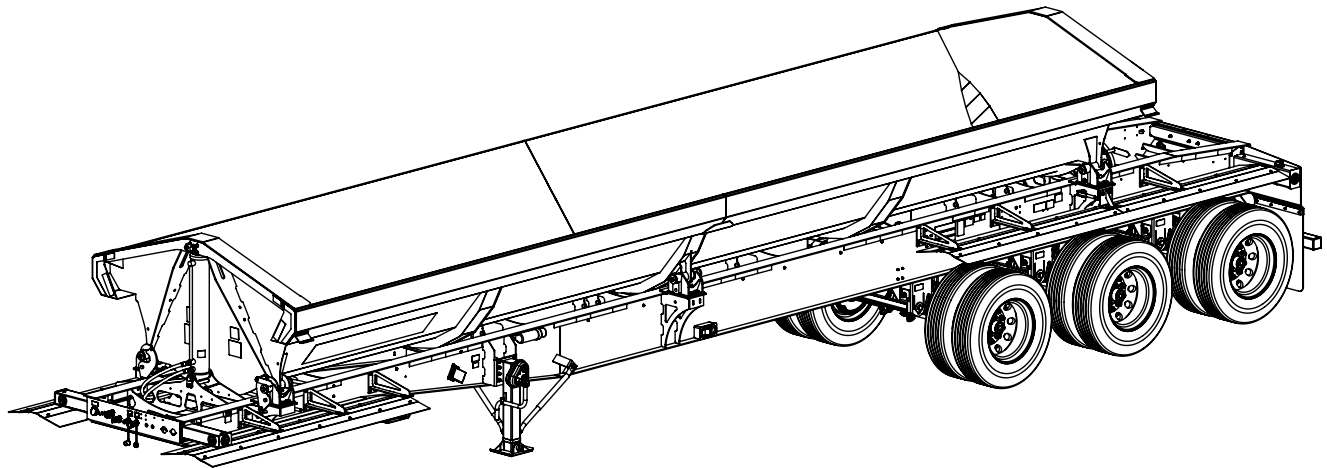

PARTS MANUAL

Overview 2
Side Dump Information 3
How To Order Parts 3

Replacement Parts 4
9-Pin Connectors..... 4
ABS Brakes -- Haldex 6
Air Supply Parts 12
Document Box and Manual Holder 16
Electrical System 17
Fender Parts -- Front 21
Fender Parts -- Rear 22
Fifth Wheel Grease Components 26
Hydraulic System 27
Jack 32
Landing Gear -- SAF-Holland 33
Pivot Latch Components 34
Remote Grease Zerk Components 35
Safety Decals/Reflectors 36
Suspension Parts -- CBX23 Standard 38
Suspension Parts -- CBX23 PosiLift™ 39
Tub Components 40

Optional Parts 42
Center Mud Flap Options 42
Electric Over Hydraulic Control Option..... 44
Electric Tarp Option -- Aero 50
Electric Tarp Option -- Roll-Rite 60
Rear Attachment Options 73
Rear Strobe Light Option 79

Side Dump Information

This parts manual is for the Demco Side Dump Models:

9CCR443AR603424 44' Chassis, Air Ride, 60' Spread, 34' Tub

9CCR443AR60RL3424 44' Chassis, Air Ride, 60'Spread, 34' Tub, With Rear Lift

Record the following information for future reference in ordering replacement parts or additional options.

Serial Number _____

Date Purchased _____

Dealer Information _____

Serial Number

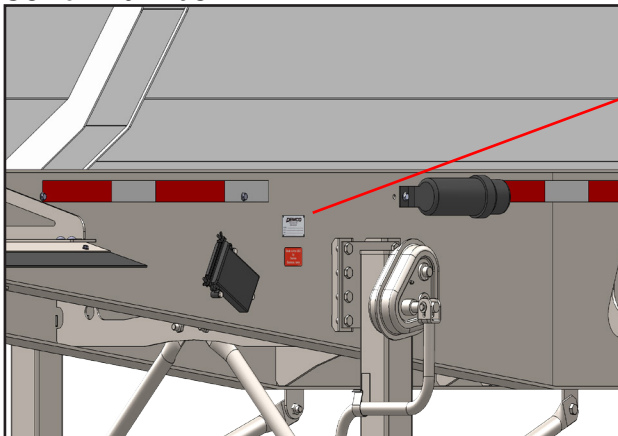

Example: VIN Number Description

57CKS4029CT627045

Demco
Side Dump
40' Length
No. of Axles
Check Digit
Model Year Demco
Demco Identifier Number
Trailer Sequence

In addition to the VIN number Demco has placed a coded unit number on the chassis and the tub.

How To Order Parts

Use this manual to help determine the part number needed, then contact your dealer with the model number, serial number, and part information. They can order the part(s) directly from Demco.

9-Pin Female Connector #1AEAP4546 Trailer Harness (View From Front)

| <i>Position</i> | <i>Color</i> | <i>Functions</i> |
|-----------------|--------------|-----------------------------|
| 1 | RED | TUB DUMP |
| 2 | WHT | TUB - RETURN |
| 3 | GRN | LIFT AXLE DOWN |
| 4 | BLK | GROUND - CENTER PIN |
| 5 | ORG | TUB SWITCH POWER |
| 6 | RED | TARP - UNCOVER |
| 7 | BLK | TARP - COVER |
| 8 | ORG | + POSITIVE (Tarp Over-Ride) |
| 9 | GRN | TARP LOCK OUT - SENSOR |

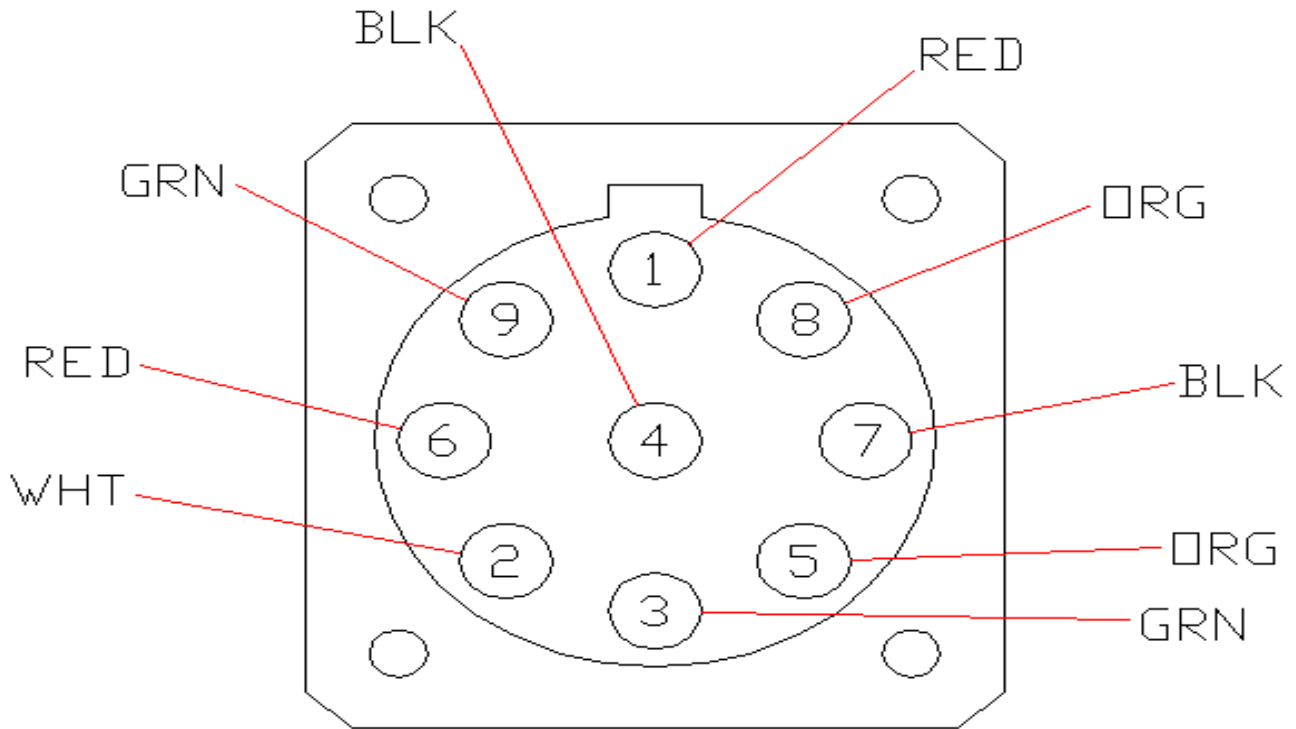

9-Pin Male Connctor #1AEAP4548 Control Box (View From Rear)

| <i>Position</i> | <i>Color</i> | <i>Functions</i> |
|-----------------|--------------|-----------------------------|
| 1 | RED | TUB DUMP |
| 2 | WHT | TUB - RETURN |
| 3 | GRN | LIFT AXLE DOWN |
| 4 | BLK | GROUND - CENTER PIN |
| 5 | ORG | TUB SWITCH POWER |
| 6 | BLU | TARP - UNCOVER |
| 7 | WHT/BLK | TARP - COVER |
| 8 | RED/BLK | + POSITIVE (Tarp Over-Ride) |
| 9 | GRN/BLK | TARP LOCK OUT - SENSOR |

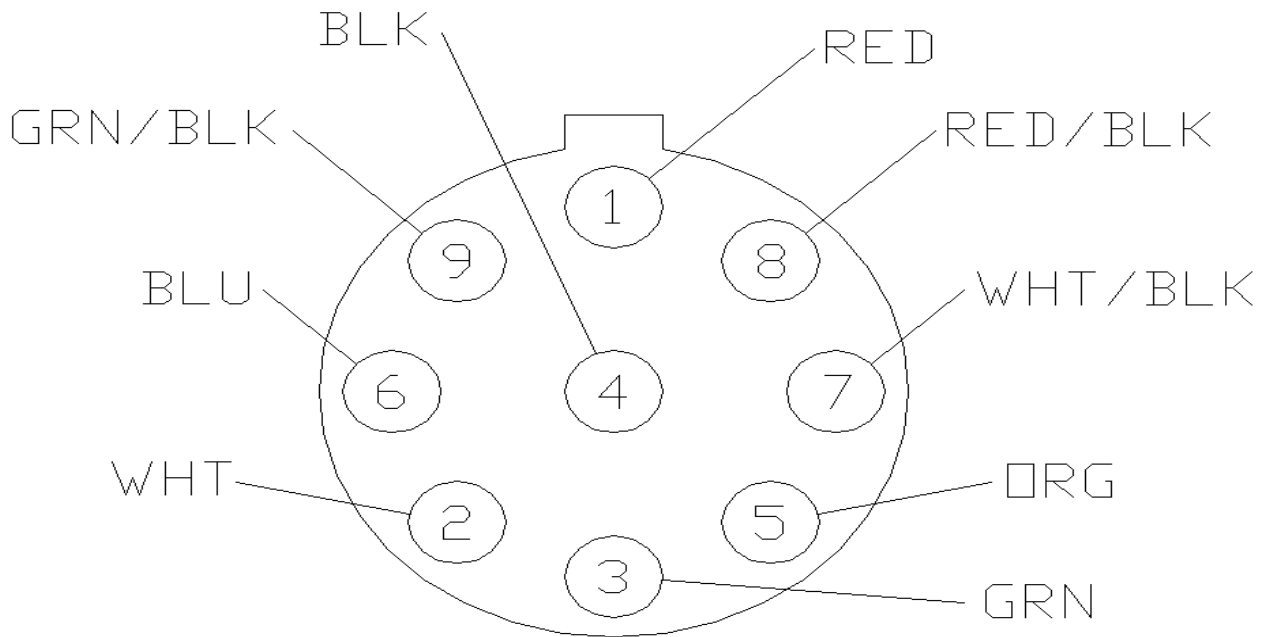

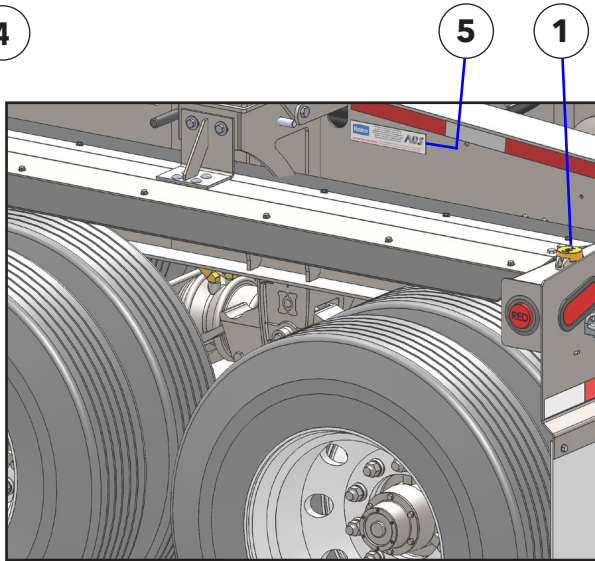
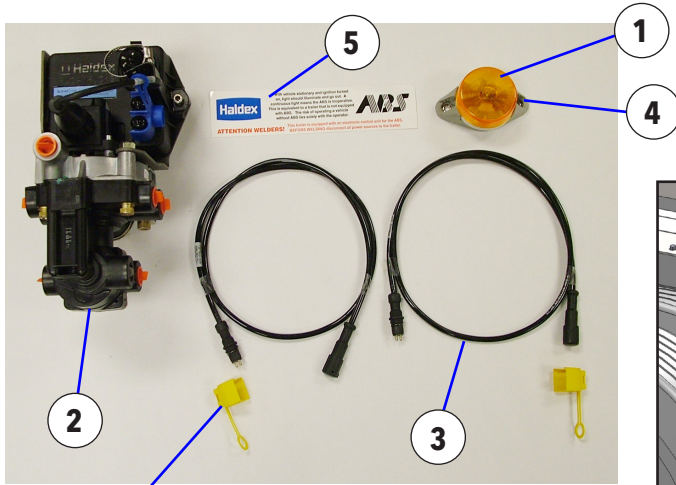

6

Haldex
 (816) 891-2470
 Valve Model: AL430624
 ECU Model: AL919323
 Visit Company's website for add'l info at:
<https://www.haldex.com/en/North-America/>

| ABS-1 Axle 2S1M System | | | |
|------------------------|-----|-----------|--|
| BOM ID | Qty | Item No | Description |
| 1 | 1 | 1AEAP4301 | ABS LIGHT BRACKET |
| 2 | 3 | 1ABAP3528 | VALVE, FFABS, 3/4" NPT, HALDEX N9001JB |
| 3 | 1 | 1ABAP3754 | ABS SENSOR EXT. CORD, 1 METER |
| 4 | 2 | 1AEAP4302 | ABS LIGHT |
| 5 | 1 | 1AQAP4304 | DECAL, ABS LIGHT/ATTN WELDERS |
| 6 | 1 | 1AAAP4308 | RETAINING CLIP, ABS SENSOR PLUG |

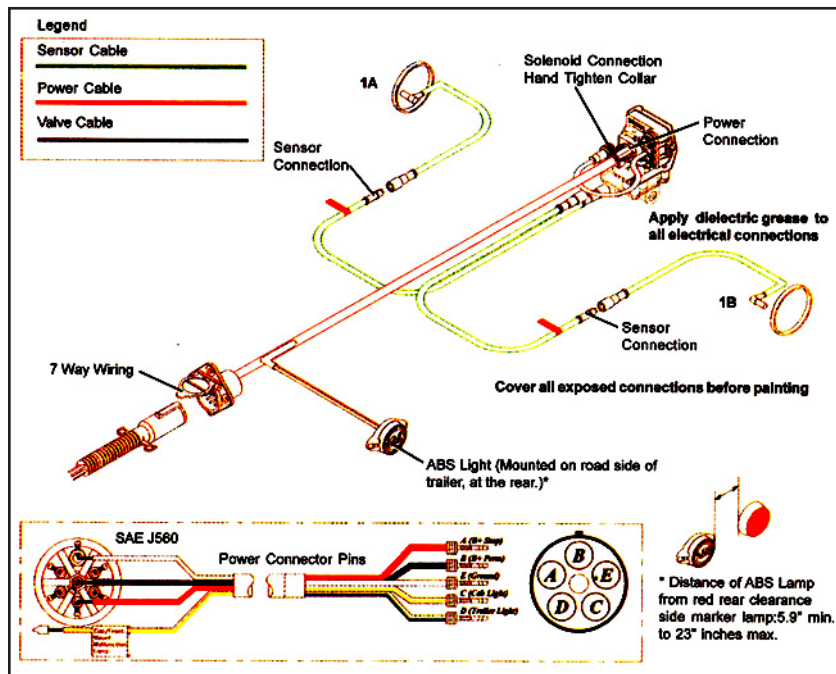

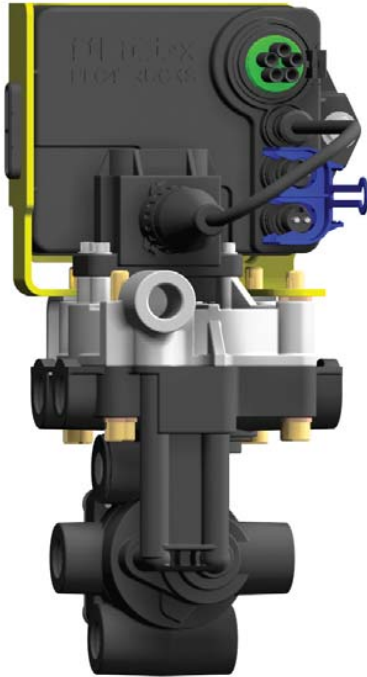

PLC Select ABS (1M)

***Installation/Service Manual
for
2S/1M Systems***

PLC Select 1M

PLC Select 1M & 2M Valve Orientation



The ABS Valve Solenoid must be installed as shown below

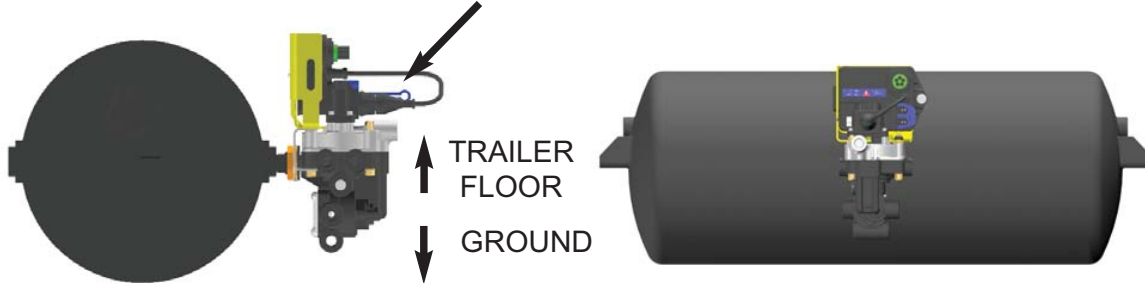

Typical tank mount valve orientation

1. Install fittings into valve. Sealant is not required on plastic threads or on fittings that go into plastic. **DO NOT** use teflon tape on fittings. It can break off and contaminate the air system. Liquid pipe sealant is approved for use if required.
2. For plastic ports, hand tighten fittings then rotate 1 to 1-1/2 additional turns. The maximum torque valve allowed is 210 in-lb.
3. Install valve nipple into reservoir port. Use 7/8" wrench to tighten the nipple.
4. Using a 1-1/2" wrench tighten the jam nut to 30 ft. lb, while holding the nipple with a 7/8" wrench.(see detail below).
5. Attach hoses to appropriate brake chambers. Use liquid thread sealant sparingly on all fittings (Loctite PST565 or equivalent).

Note: *If frame mounted follow same procedure for valve orientation. Valve solenoid on a 2-port relay, 6-port relay or FFABS must be facing up when the trailer is in normal operation or service/ABS performance could be effected.*

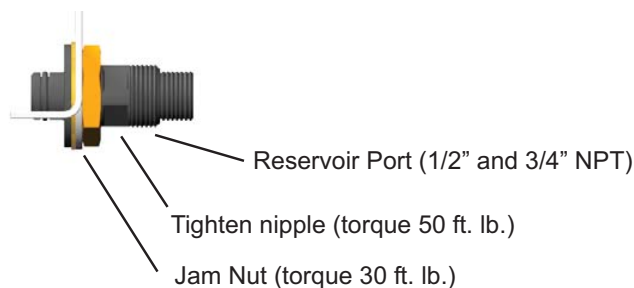

Warning: *Proper installation orientation shown above; otherwise, warranty is void. Installation behind the tank is recommended, facing the back of the trailer.*



PLC Select FFABS 2S/1M
(4 Service Delivery Ports/ 4 Spring Brake Ports)

- Air suspension typically have the sensors on the rear axle
- Spring suspension typically have the sensors on the front axle



PLC Select 1M (FFABS)

Plumbing Schematic (2S/1M)
Top View

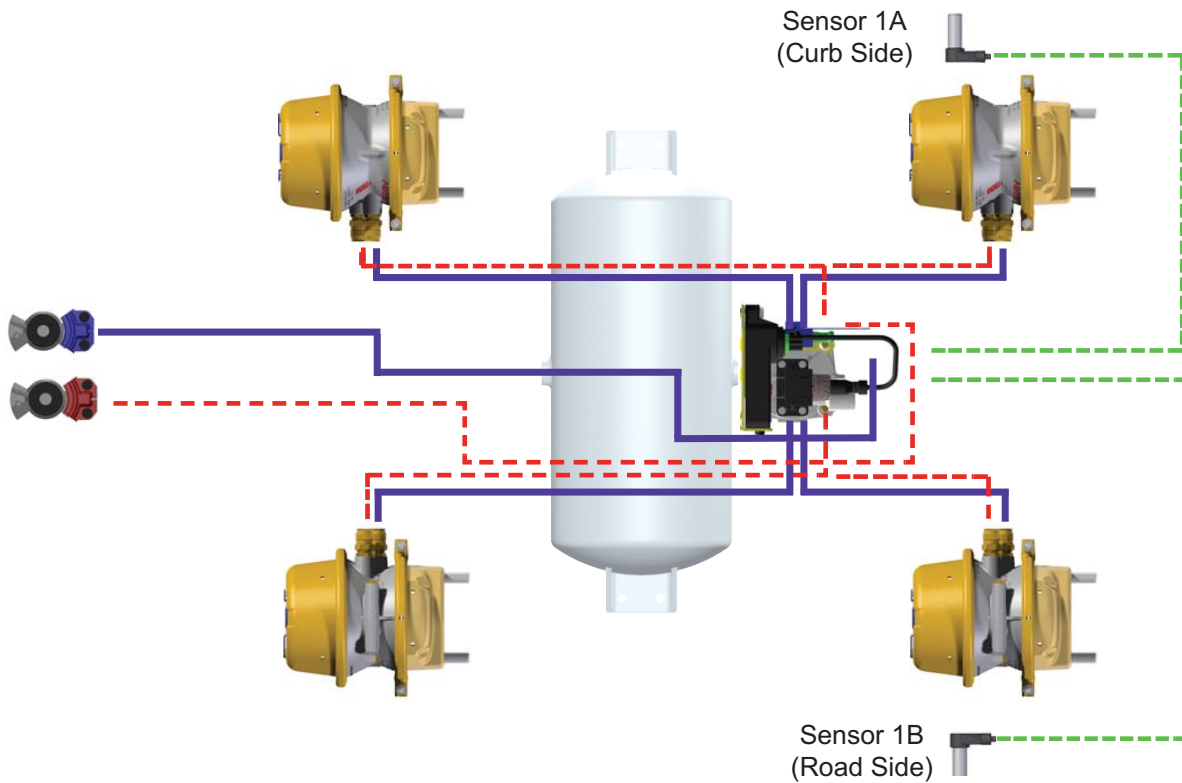

Legend:

| | |
|-----------------------|--|
| Service/Control Line | |
| Emergency/Supply Line | |
| Sensor Line | |

AIR BRAKE COMPONENTS AND SYSTEM SCHEMATIC ARE DESIGNED TO ALLOW COMPLIANCE WITH FMVSS 121.

THIS SCHEMATIC IS FOR INFORMATION PURPOSE ONLY. IT IS THE VEHICLE MANUFACTURERS ULTIMATE RESPONSIBILITY TO CERTIFY THEIR SYSTEM MEETS ALL APPLICABLE REGULATIONS.

PIPE NIPPLES USED TO MOUNT BRAKE VALVES MUST BE HEAVY WALL TYPE PER SAE J514.

PLC Select 1M



ABS Power Cord - Pin Out

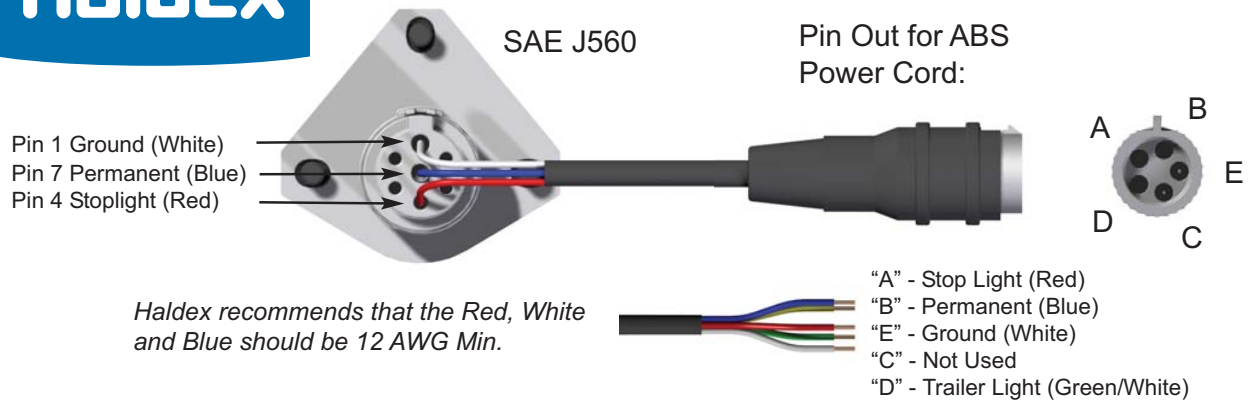

Note: Federal regulations mandate that new trailers, built after 3/1/2001, have the capability to provide an ABS fault signal from the trailer ABS into the tractor for an In-Cab trailer ABS Lamp. Option (1) is through Industry standard "PLC4Trucks" multiplexing (the signal is carried on Pin 7)

PLC Select 1M ECU Overview

Correct location of the speed sensors at the wheel ends is critical for proper ABS operation and troubleshooting. The PLC Select 1M will adjust the braking air pressure in response to the input from the speed sensors. Incorrect installation or location of speed sensors, sensor block clips and exciter rings will result in poor ABS performance or sensors crossed leading to incorrect diagnostics troubleshooting.

The figure below shows the correct power and speed sensor connections on the PLC Select 1M ECU (Electronic Control Unit).

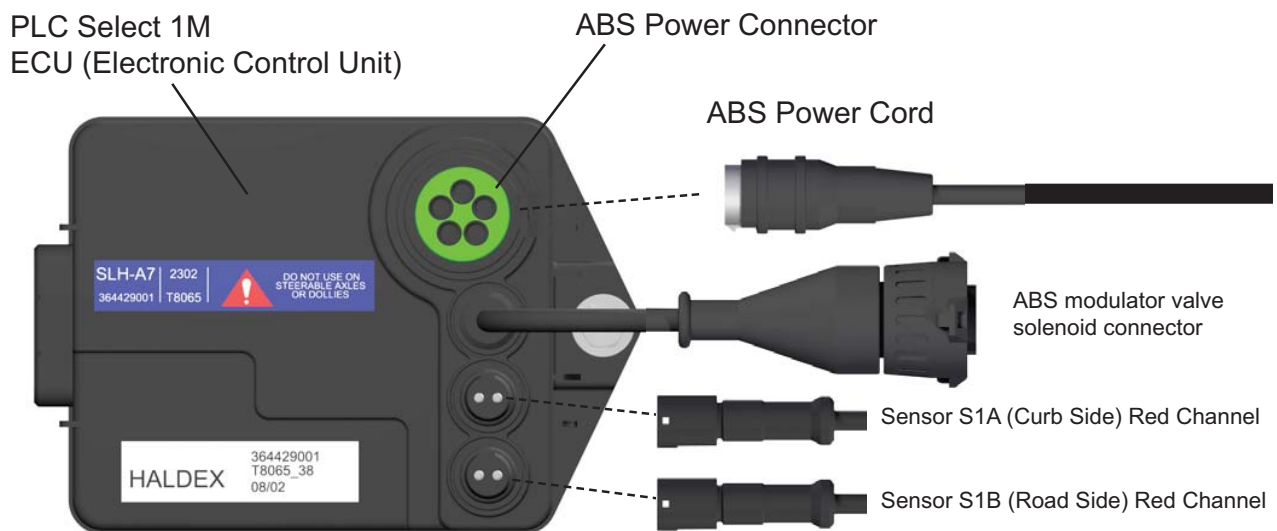

Note: When installing and servicing always apply small amount of dielectric grease to all electrical connections.

PLC Select 1M

2S/1M System Wiring - PLC Select



Note: Cover all exposed electrical connections before painting



*Distance of ABS Light from Red rear clearance side marker light is 5.9" inches to 23" inches max.

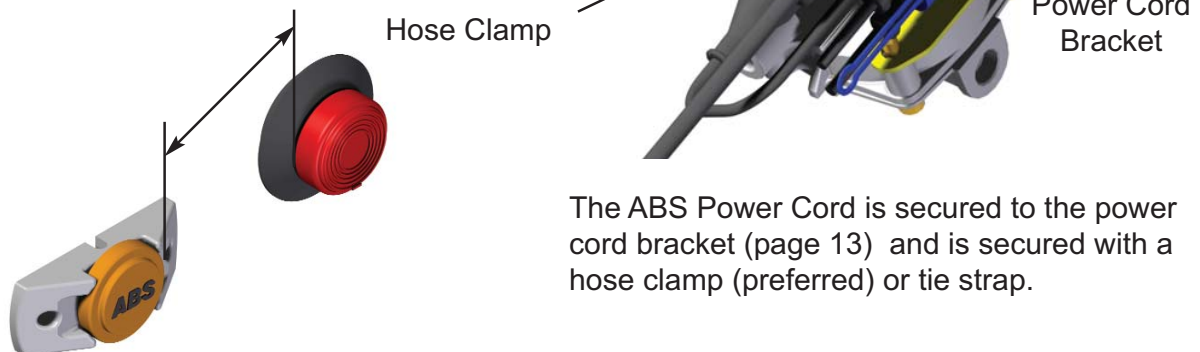

PLC Select 1M

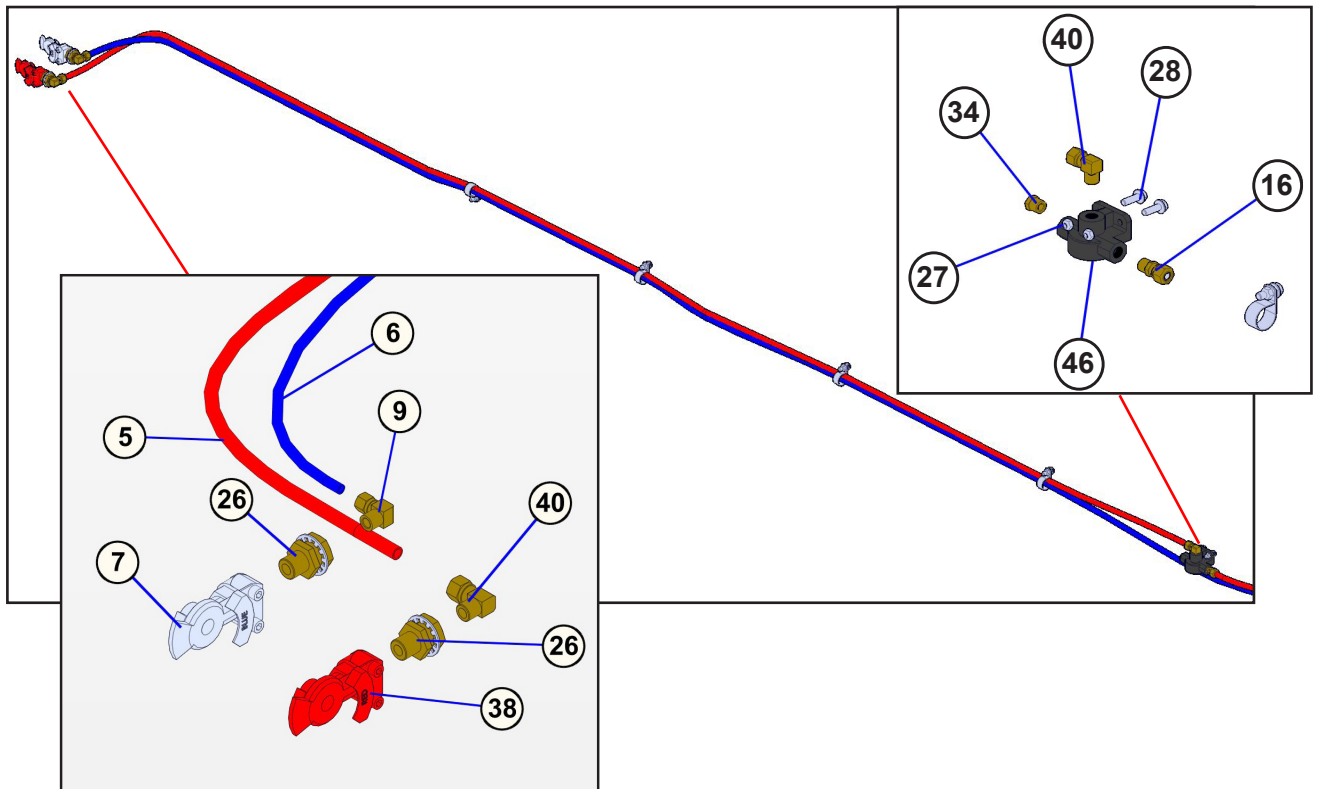
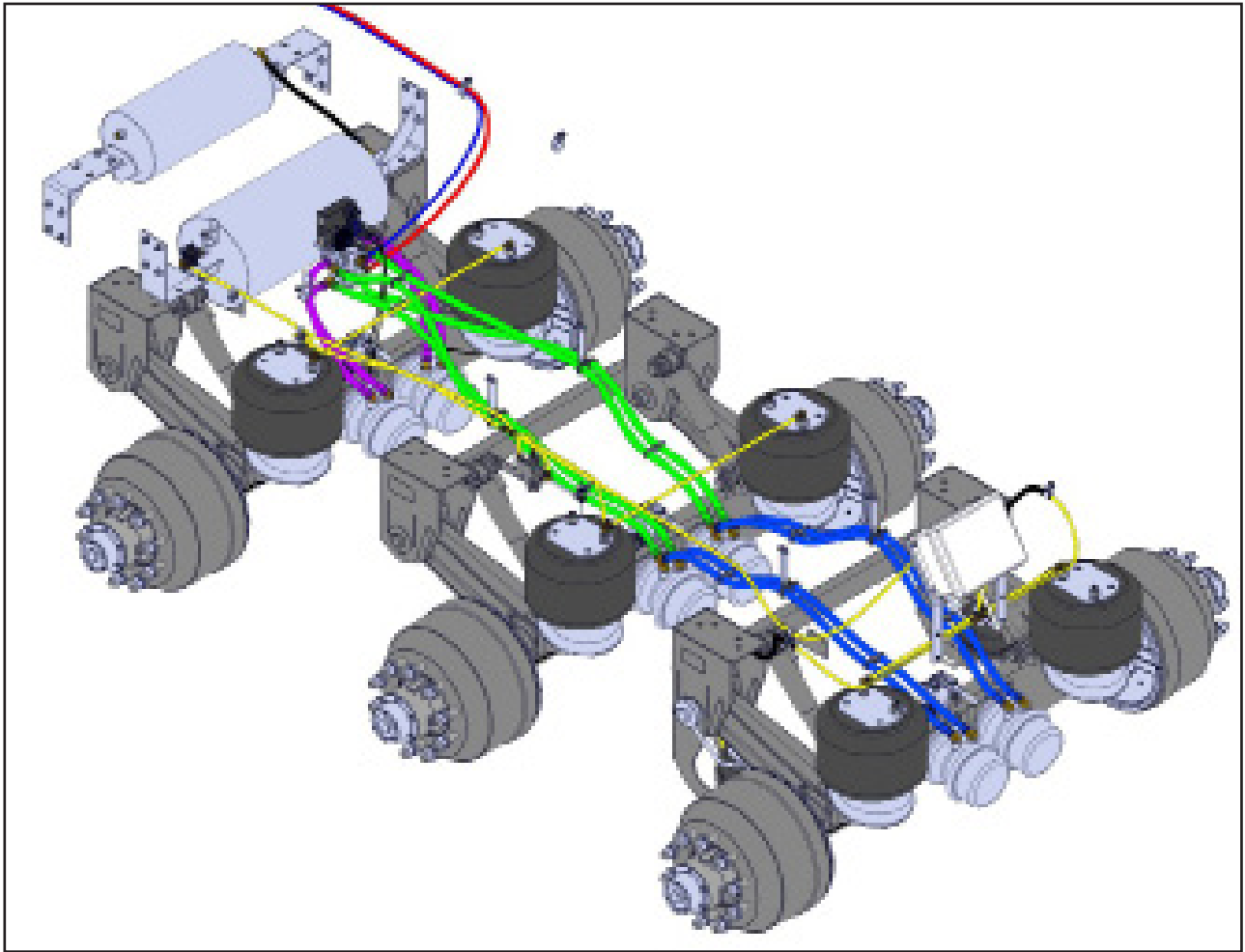

NOTE:
See Parts List
on next pages

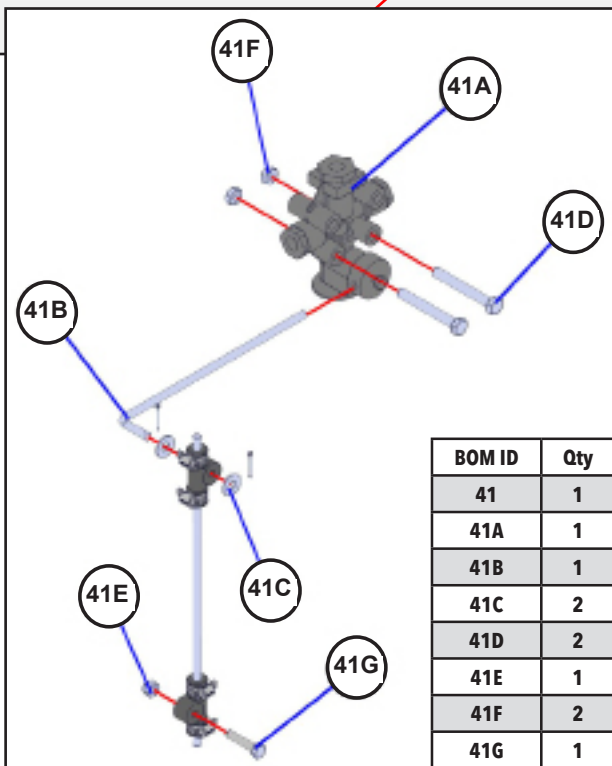
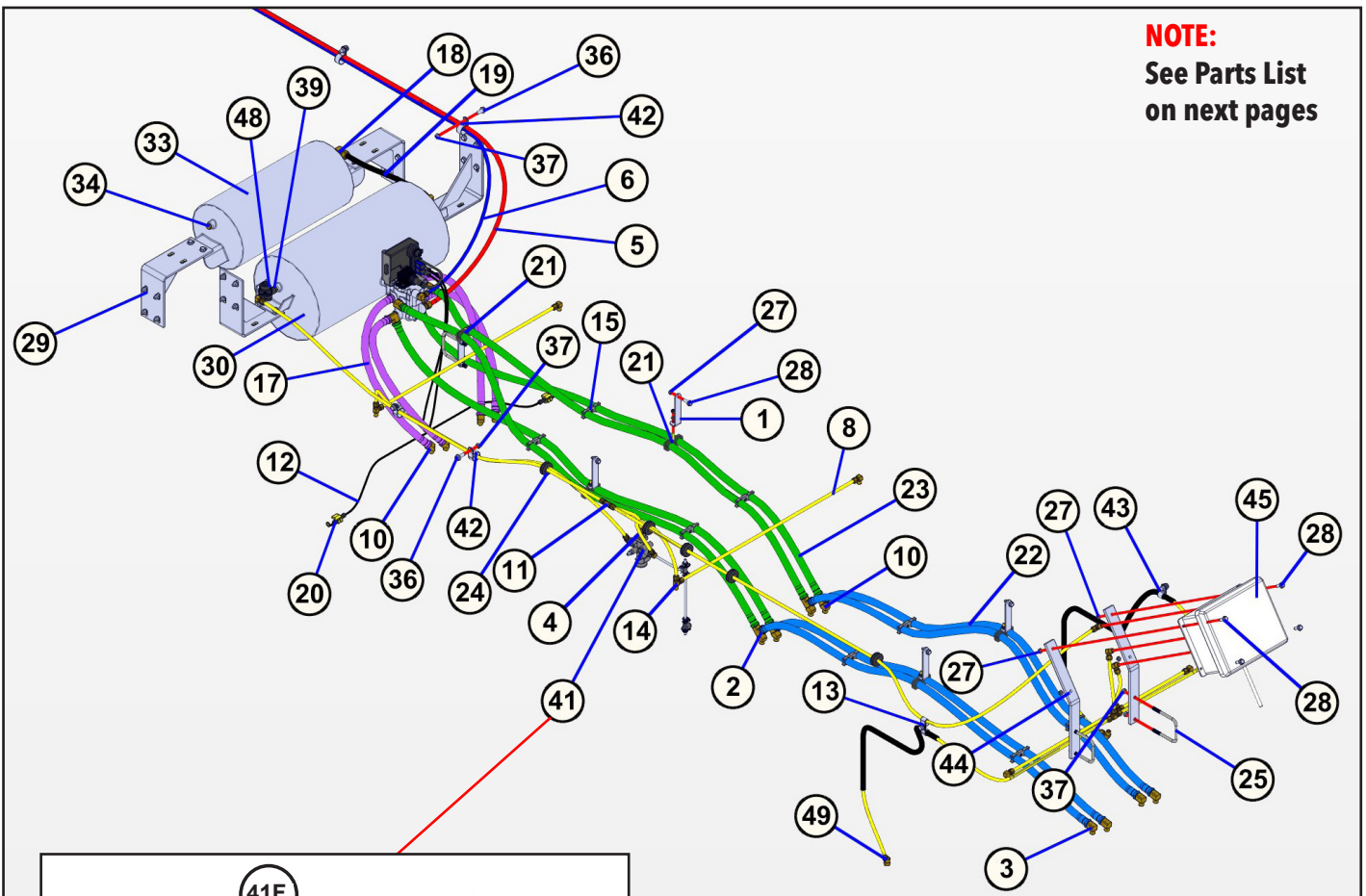

| BOM ID | Qty | Item No | Description |
|--------|-----|---------|---|
| 41 | 1 | CR HCV | HEIGHT CONTROL VALVE ASSEMBLY |
| 41A | 1 | AP4204 | AIR CONTROL VALVE, IR, HOLLAND-NEWAY |
| 41B | 1 | AP4205 | HEIGHT CONTROL VALVE LINKAGE KIT |
| 41C | 2 | BP3055 | WASHER, FLAT, 1/4", PLATED |
| 41D | 2 | BP3111 | HEX CAP SCREW, 5/16"-18 S 2-1/2", GRADE 5, PLATED |
| 41E | 1 | BP3587 | NUT, HEX, 1/4" NYLOCK |
| 41F | 2 | BP3644 | NUT, HEX LOCK, 5/16"-18, TOP LOCK |
| 41G | 1 | BP3648 | BOLT, 1/4" X 1-1/4" GRADE 8 |

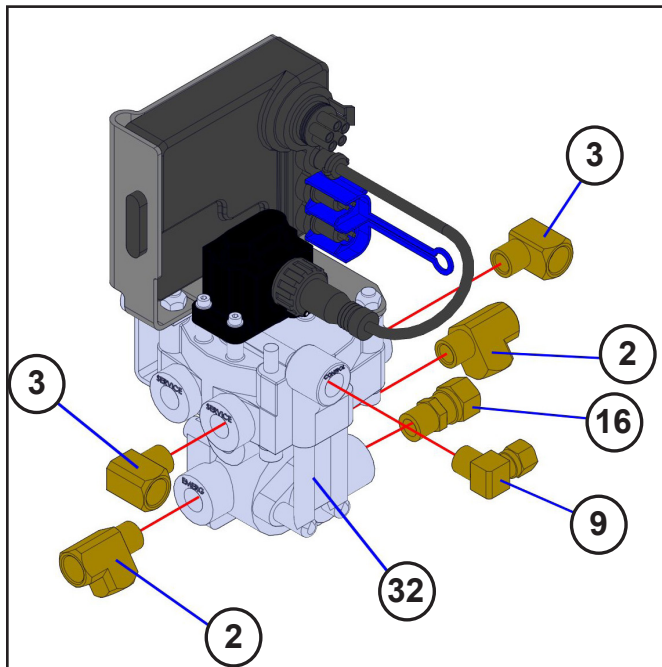
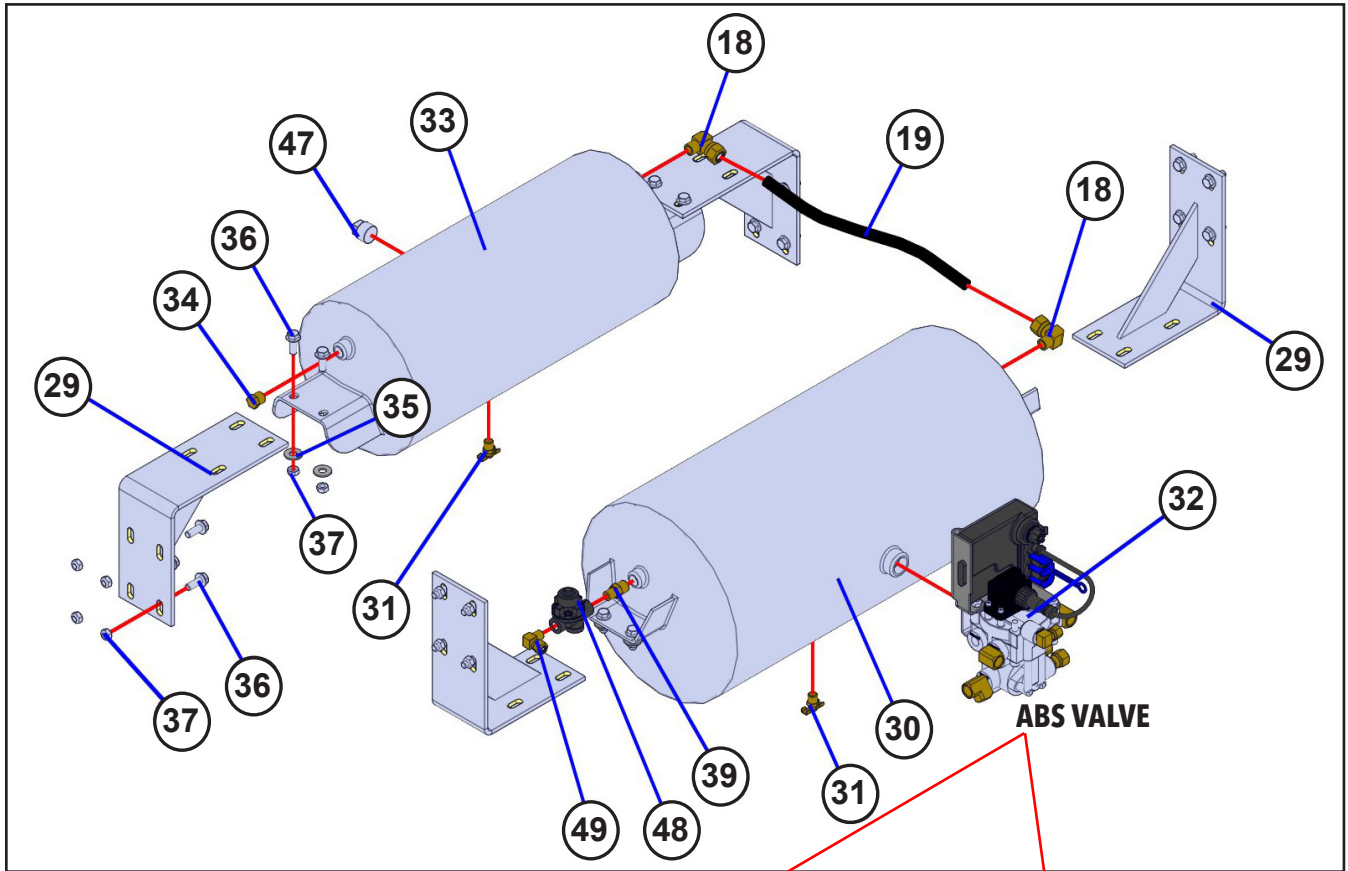

LEFT HAND VIEW

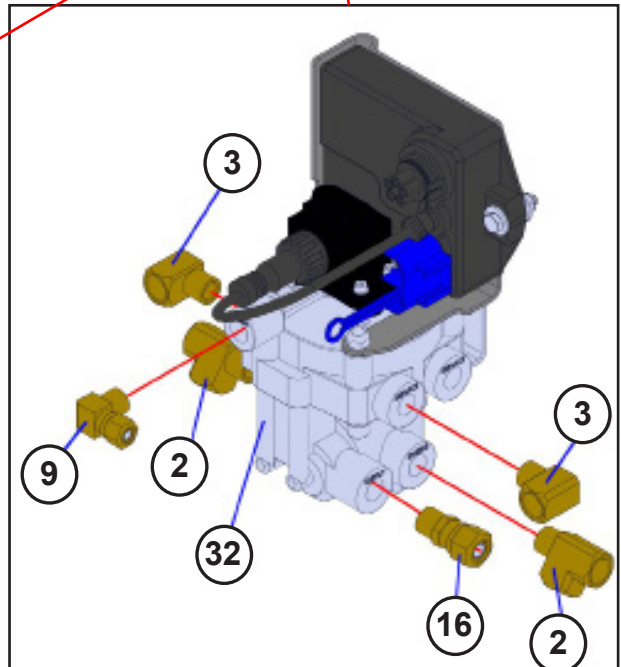

RIGHT HAND VIEW

| BOM ID | Qty | Item No | Description |
|--------|-----|-------------|---|
| 1 | 5 | 3CAM9377 | HOSE HOLDER, AIR BRAKE |
| 2 | 6 | 1ARAP3531 | STREET TEE, 3/8", 90 DEGREE |
| 3 | 6 | 1AEAP3532 | STREET ELBOW, 3/8", 90 DEGREE |
| 4 | 1 | 1AKAP3534 | ADAPTER, 1/4" MP X 3/8" TUBE, STRAIGHT, BRASS |
| 5 | 2 | 1ABAP3537 | NYLON TUBING, RED, 1/2" |
| 6 | 1 | 1ABAP3538 | NYLON TUBING, BLUE, 3/8" |
| 7 | 1 | 1ABAP3555 | GLADHAND, SERVICE, BLUE |
| 8 | 1 | 1ABAP3683 | NYLON TUBING, YELLOW, 3/8" |
| 9 | 2 | 1ABAP3687 | ELBOW, 3/8" MP X 3/8" TUBE, 90 DEGREE, BRASS |
| 10 | 8 | 1ABAP3688 | STREET ELBOW, 3/8", 45 DEGREE |
| 11 | 3 | 1ABAP3717 | TEE, UNION, 3/8" TUBE |
| 12 | 2 | 1ABAP3754 | ABS SENSOR CORD, 1 meter |
| 13 | 1 | 1AEAP3805 | 1/2" HOSE SUPPORT CLAMP, 3/8" BOLT |
| 14 | 2 | 1ABAP3813 | TEE, RUN, 1/4" MP X 3/8" TUBE X 3/8" TUBE, BRASS |
| 15 | 8 | 1ABAP3864 | AIR BRAKE HOSE SEPARATOR, 1/2" HOSE |
| 16 | 2 | 1ABAP4200 | TUBE, 1/2" X 3/8" MP, STRAIGHT, NUT & FERRULE, BRASS |
| 17 | 4 | 1AQBAP4210 | HOSE, 1/2" AIR BRAKE X 26", 3/8"MP-3/8"MPX |
| 18 | 2 | 1ABAP4243 | TUBE, 5/8" X 3/8" MP, 90 DEGREE, NUT & FERRULE, BRASS |
| 19 | 3 | 1ABAP4244 | NYLON TUBING, BLACK, 5/8" |
| 20 | 2 | 1AAAP4308 | RETAINING CLIP, ABS SENSOR PLUG |
| 21 | 5 | 1ABAP4392 | HOSE CLAMP, 2 HOLE, 1/2" AIR BRAKE HOSE |
| 22 | 4 | 1ABAP4468 | HOSE, 1/2" AIR BRAKE X 72", 3/8"MP-3/8"MPX |
| 23 | 4 | 1ABAP4513 | HOSE, 1/2" AIR BRAKE X 84", 3/8"MP-3/8"MPX |
| 24 | 5 | 1ABAP4549 | GROMMET, 1-3/8" OD X 1" ID X 3/8" |
| 25 | 3 | 1AFBP3362 | U-BOLT, 3/8"-16 X 3"W X 4"L |
| 26 | 2 | 1AFBP3584 | BOLT, TERMINAL, HB646 |
| 27 | 10 | 1AFBP3644 | NUT, HEX LOCK, 5/16"-18, TOP LOCK |
| 28 | 10 | 1AFBP3709 | BOLT, FLANGE HEAD, 5/16"-18 X 1", GRADE 8, PLATED |
| 29 | 4 | 5CAM9018 | BRACKET, AIR TANK MOUNTING |
| 30 | 1 | 1ABAP3524 | AIR TANK, 2800 CU IN |
| 31 | 2 | 1ABODDRAIN0 | DRAIN COCK, 1/4" NPT |
| 32 | 1 | 1ABAP3528 | VALVE, FFABS, 3/4" NPT, HALDEX N9001BB, TRAILER |
| 33 | 1 | 1ABAP3554 | AIR TANK, 1488 CU IN |
| 34 | 2 | 1ABAP3692 | HEX PLUG, 3/8", BRASS |
| 35 | 8 | 1AFBP3015 | WASHER, FLAT, 3/8", PLATED |
| 36 | 41 | 1AFBP3692 | BOLT, FLANGE HEAD, 3/8"-16 X 1", GRADE 8, PLATED |
| 37 | 27 | 1AFBP3612 | NUT, HEX LOCK, 3/8"-16, TOP LOCK |
| 38 | 1 | 1ABAP3556 | GLADHAND, EMERGENCY, RED |
| 39 | 1 | 1ABAP4201 | NIPPLE, HEX REDUCER, 3/8"MP X 1/4"MP, BRASS |
| 40 | 2 | 1ABAP4199 | TUBE, 1/2" X 3/8"MP, 90 DEGREE, NUT & FERRULE, BRASS |
| 41 | 1 | CR HCV | HEIGHT CONTROL VALVE ASSEMBLY |
| 42 | 15 | 1AFAP3809 | 1-1/4" HOSE SUPPORT CLAMP, 3/8" BOLT |
| 43 | 2 | 1AEAP3806 | 3/4" HOSE SUPPORT CLAMP, 3/8" BOLT |
| 44 | 2 | 3CAM9193 | BRACKET, MOUNTING, LIFT AXLE CONTROL BOX |
| 45 | 1 | 1AAAP4306 | VALVE ASSEMBLY, LIFT AXLE CONTROL |
| 46 | 1 | 1ABAP3752 | QUICK RELEASE VALVE |
| 47 | 1 | 1AUCP2479 | PLUG, SQUARE HEAD, 3/4" NPT, BLACK |
| 48 | 1 | 1AKDP6323 | VALVE, AIR PRESSURE PROTECTION WITH FILTER |
| 49 | 12 | 1AKDP6326 | ELBOW, 1/4" MP X 3/8" TUBE, 90 DEGREE, BRASS |

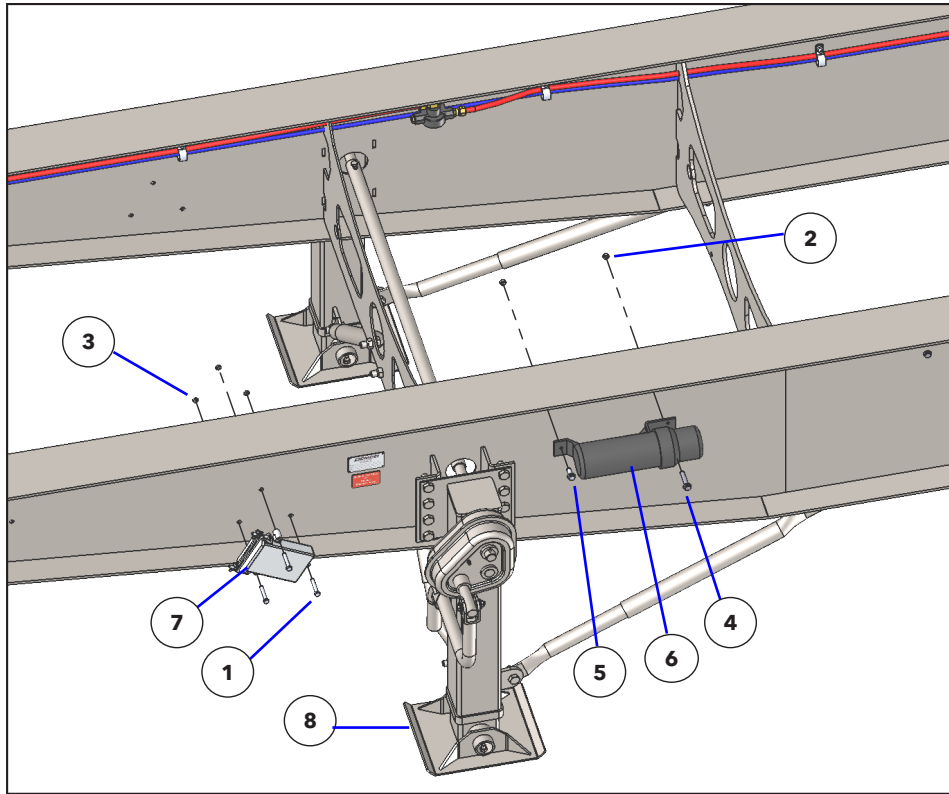

| BOM ID | Qty | Item No | Description |
|--------|-----|------------|---|
| 1 | 3 | 1AFBP3601 | HEX CAP SCREW, 5/16"-18 X 2", GR 5, PLTD |
| 2 | 2 | 1AFBP3612 | NUT, HEX LOCK, 3/8"-16, TOP LOCK, PLTD |
| 3 | 3 | 1AFBP3644 | NUT, HEX LOCK, 5/16"-18, TOP LOCK, PLTD |
| 4 | 1 | 1AFBP3685 | BOLT, FLANGE HEAD, 3/8"-16 X 2", GR 8, PLTD |
| 5 | 1 | 1AFBP3692 | BOLT, FLANGE HEAD, 3/8"-16 X 1", GR 8, PLTD |
| 6 | 1 | 1AU0000011 | MANUAL HOLDER, BLACK |
| 7 | 1 | 1AUAP3811 | JAMES KING DOCUMENT BOX, NO. 300 |
| 8 | 1 | 4CPKG00112 | PACKAGE, LANDING GEAR, SIDE DUMP |

Lights and Wiring

The lights and wiring system on every Demco Side Dump trailer meet or exceed all federal and state requirements in effect at the time of manufacture. Wherever required by law, lights and reflectors are marked by the manufacturer to indicate the appropriate specifications with which each complies.

For optimum performance and long life from the trailer's lights and wiring, follow this inspection procedure:

1. Clean all reflectors and lights. See that all lights burn properly. Replace all burned out lights and broken reflectors. Factory approved replacement parts should be used, and replacement bulbs of equal candle power should be used for safety.

⚠ WARNING! Use only a 12 volt DC battery for checking lights or anti-lock systems. Never use battery chargers or transformers.

2. Inspect all wiring to see that it is not frayed, and that it is properly supported and protected, with all connections tight. See that the light cable is clean and long enough to permit jackknife parking. Be certain that the cable is supported so that it cannot be pinched or entangled by the lower and upper couplers. Keep the 7-way plug on the light cable and the 7-way connector on the trailer free of corrosion.
3. Never replace fuses or breakers with metal foil or other devices.
4. A decal is located near the 7-way connector. You may trace individual electrical circuits by the wire colors indicated. Refer to the schematic drawing and the decal for conductor number and wire colors.

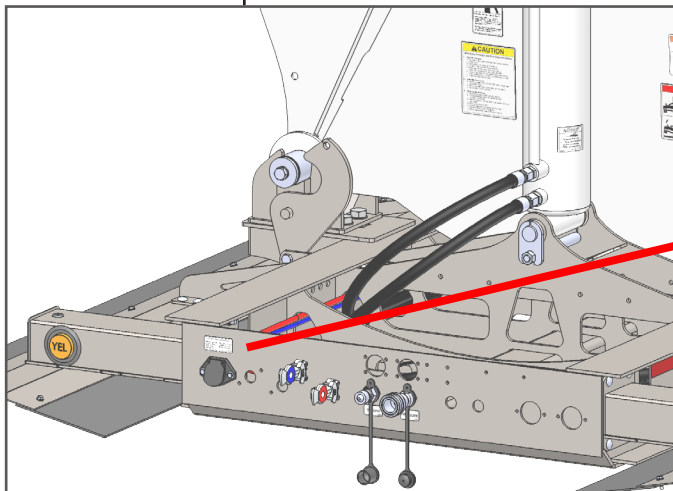

Wiring Harness Color Code

| | |
|----------------|------------------|
| WHITE - Ground | YELLOW - Lt Turn |
| BLACK - Marker | GREEN - Rt Turn |
| RED - Stop | BLUE - Auxiliary |
| BROWN - Tail | |

AP 3674

1AQAP3674
WIRING HARNESS COLOR CODE DECAL

ELECTRICAL SYSTEM

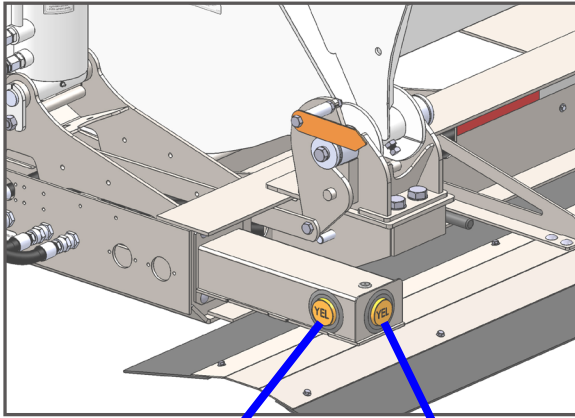

4 5

4 5

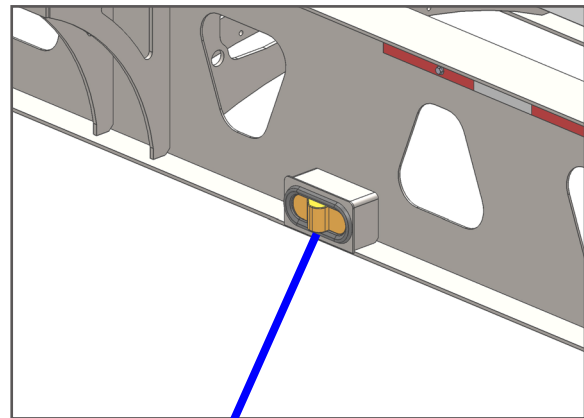

8 9

3 5

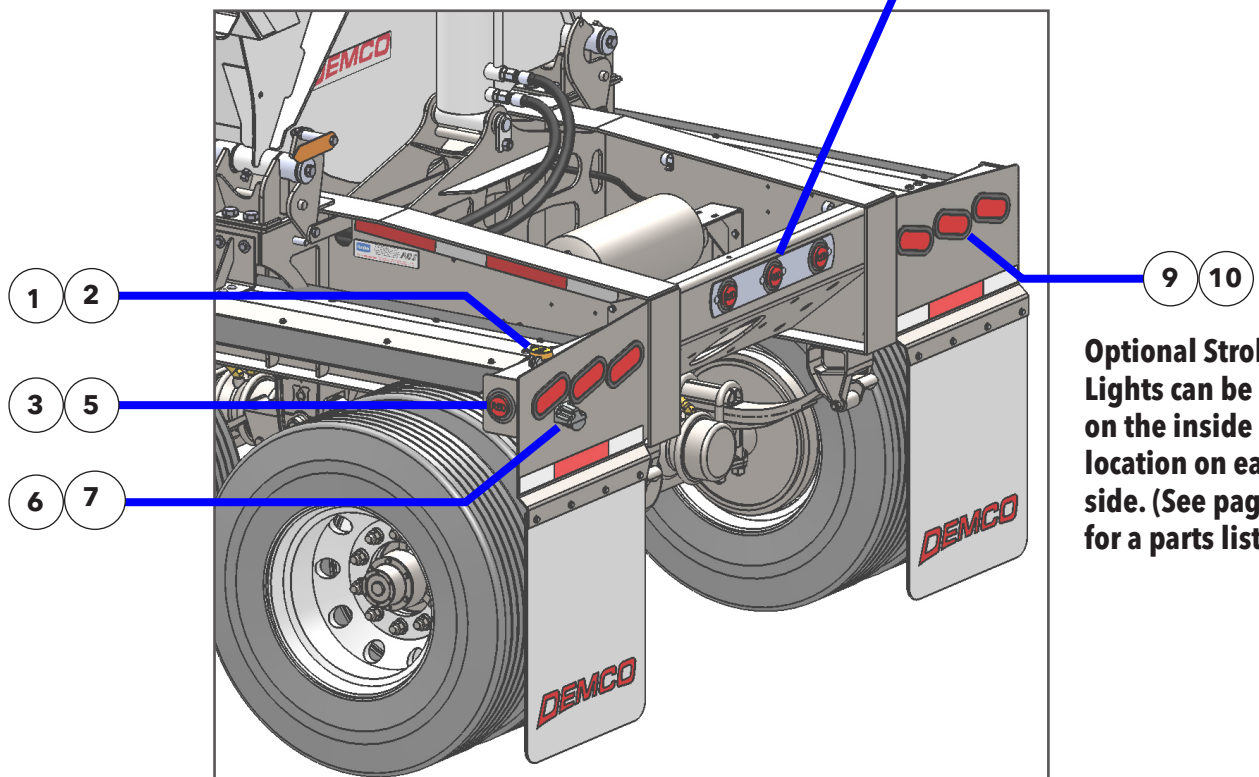

1 2

3 5

6 7

9 10

Optional Strobe Lights can be added on the inside light location on each side. (See page 82 for a parts list.)

| BOM ID | Qty | Item No | Description |
|--------|-----|-------------|--------------------------------|
| 1 | 1 | 1AEAP4301 | ABS LIGHT BRACKET |
| 2 | 1 | 1AEAP4302 | ABS LIGHT |
| 3 | 5 | 1AEAP4310 | LAMP, LED, M/C, RED, 2-1/2" |
| 4 | 4 | 1AEAP4311 | LAMP, LED, M/C, YELLOW, 2-1/2" |
| 5 | 9 | 1AEG0010700 | 2-1/2" ROUND GROMMET ONLY |
| 6 | 1 | 1AEL0015208 | LICENSE LAMP |
| 7 | 1 | 1AEL0015730 | BRACKET-BLACK |
| 8 | 2 | 1AEL060215Y | MIDSHIP TURN LAMP |
| 9 | 8 | 1AEL0607003 | 6" OVAL LIGHT GROMMET |
| 10 | 6 | 1AEL6050000 | LAMP, LED, S/T/T, RED, 6" OVAL |

| BOM ID | Qty | Item No | Description |
|--------|-----|-------------|---------------------------------------|
| 11 | 2 | 1AEP0094972 | HARNESS, M/C PLUG, WITH M-BULLETS |
| 12 | 1 | 1AEX0088300 | HARNESS, ID 3 PLUG, LOWER, 60" |
| 13 | 1 | 1AEX0088911 | HARNESS, REAR S/T/T, RH & LH |
| 14 | 2 | 1AEX0094932 | HARNESS, 2-PLUG Y-ADAPTER |
| 15 | 1 | 1AEX3030024 | HARNESS, LICENSE LAMP, 24" |
| 16 | 2 | 1AEX3270084 | HARNESS, FRONT M/C, 84" |
| 17 | 1 | 1AEX3550096 | HARNESS, LH MIDSHIP LIGHT, 96" |
| 18 | 1 | 1AEX3560048 | HARNESS, RH MIDSHIP LIGHT, 48" |
| 19 | 1 | 1AEX5220312 | HARNESS, ABS JUMPER, 312" |
| 20 | 1 | 1AEX8502027 | HARNESS, FRONT NOSE W/ BL-WHT DROPOUT |
| 21 | 1 | 1AEX8810240 | HARNESS, ABS POWER, 240" |
| 22 | 1 | 1AEX9751552 | HARNESS, 7 COND MAIN W/BRKOUT, 552" |

Note: Images of some of these parts are continued on the next page.

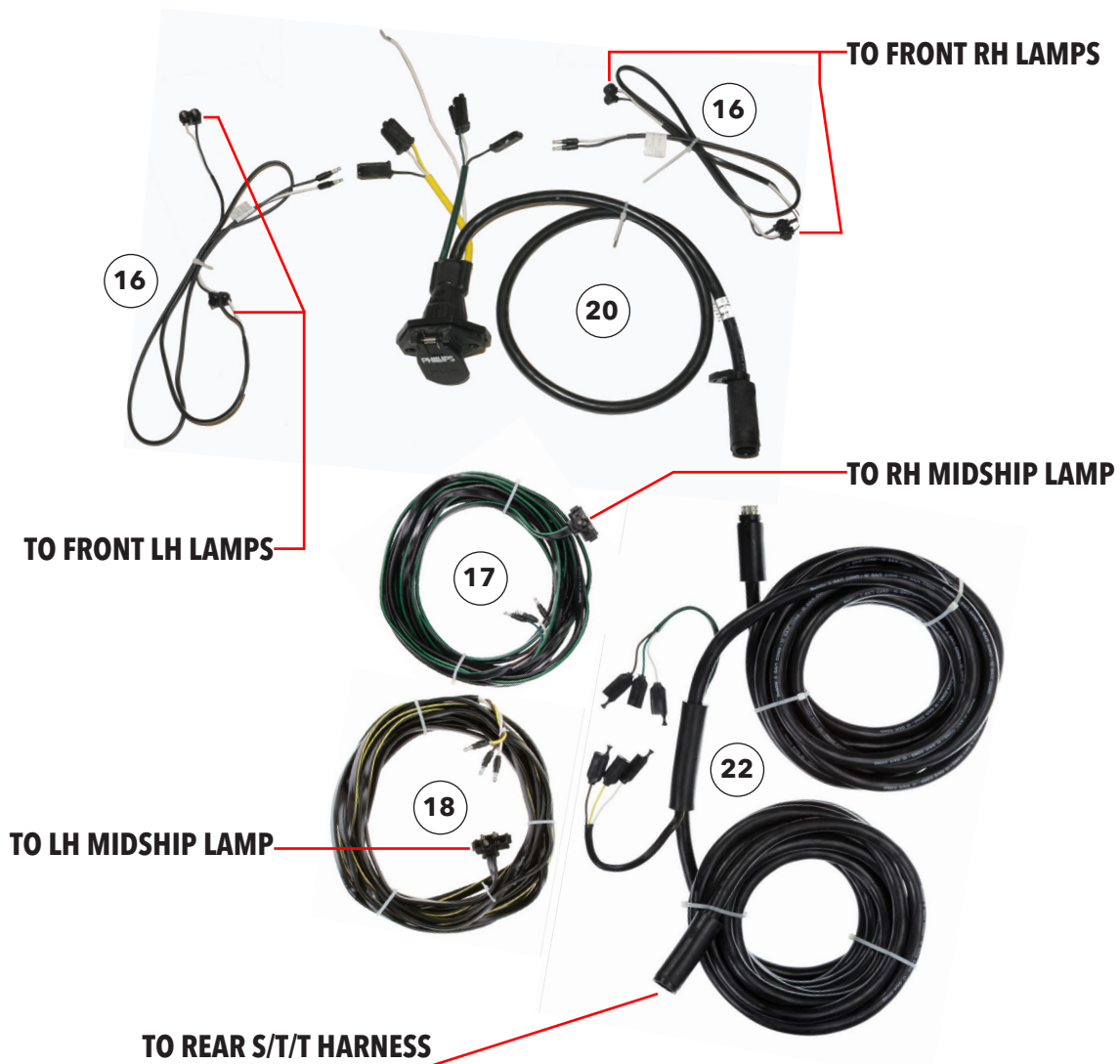

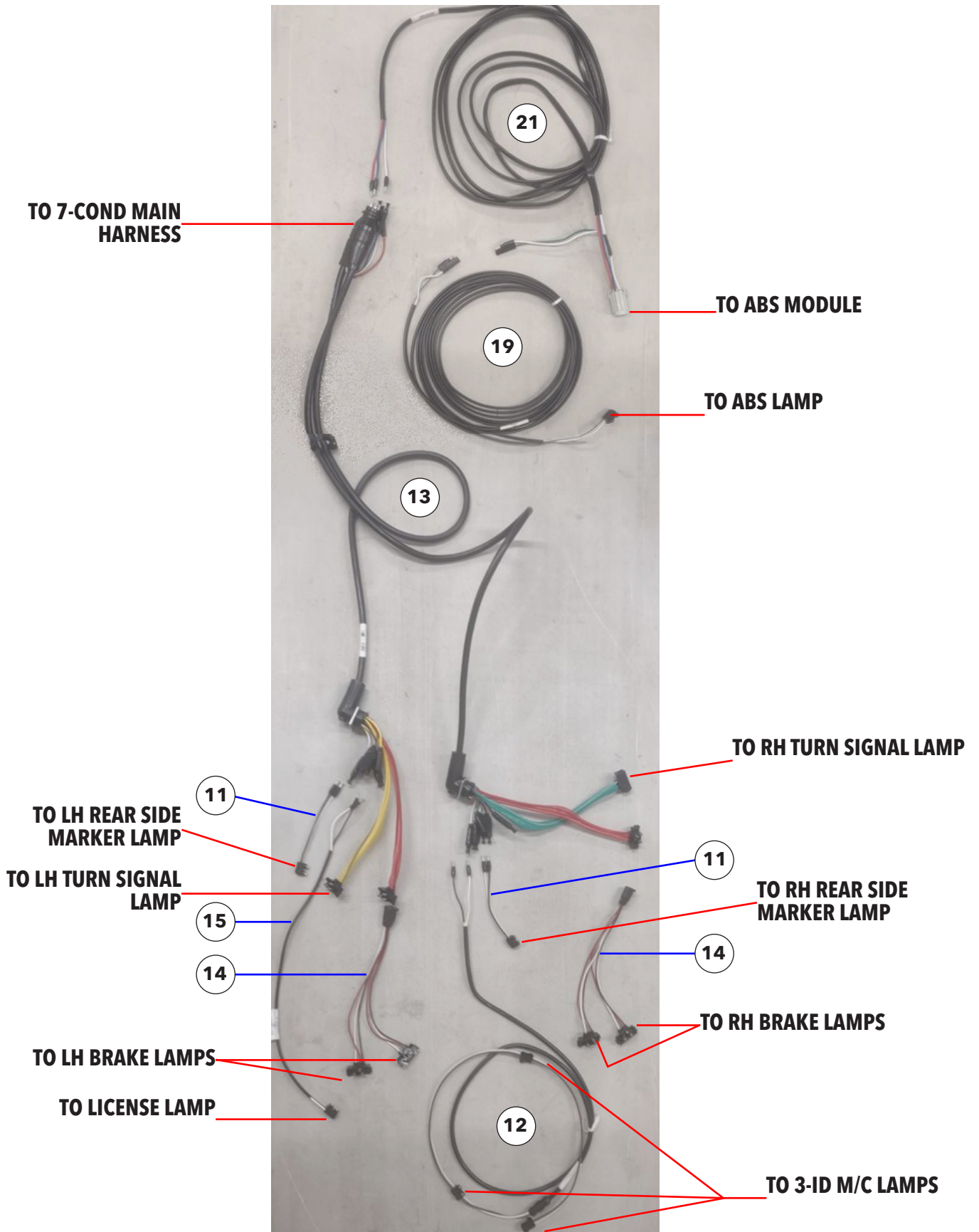

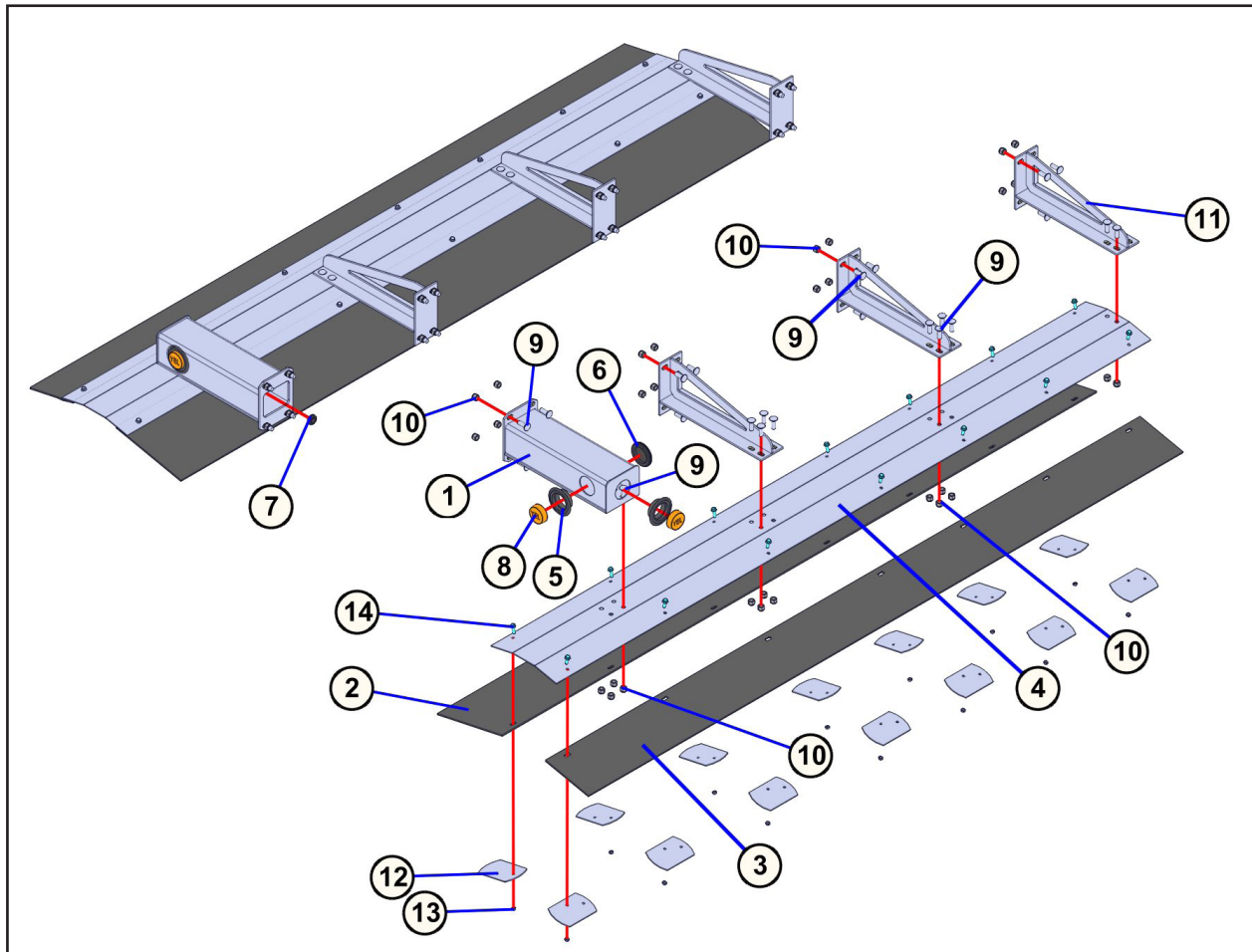

| BOM ID | Qty | Item No | Description |
|--------|-----|-----------|---|
| 1 | 2 | 5CAM9005 | FRONT LIGHT/FENDER MOUNT |
| 2 | 2 | 3CAM9091 | FENDER RUBBER, 12" X 108", FRONT |
| 3 | 2 | 3CAM9092 | FENDER RUBBER, 8" X 108", FRONT |
| 4 | 2 | 3CAM9386 | FENDER SUPPORT, FRONT, 2013 |
| 5 | 4 | 1AEAP3548 | LAMP, SUPER 10 GROMMET, 10700-3 |
| 6 | 2 | 1ARAP4010 | GROMMET, PLUG, 2-3/4" HOLE, G8077-046000 |
| 7 | 2 | 1ARAP4045 | GROMMET, 3/4" ID G3137-016 |
| 8 | 4 | 1AEAP4311 | LAMP, LED, CLEAR/MARKER, YELLOW, 2-1/2" |
| 9 | 60 | 1AFBP3232 | BOLT, CARRIAGE, 1/2"-13 X 1-1/2", GRADE 5 |
| 10 | 60 | 1AFBP3704 | NUT, LOCK, NYLON INSERT, 1/2"-13 |
| 11 | 6 | 5CAM9004 | FRAME FENDER MOUNT |
| 12 | 28 | 3CAM9089 | FENDER WASHER |
| 13 | 28 | 1AFBP3644 | NUT, HEX LOCK, 5/16"-18, TOP LOCK |
| 14 | 28 | 1AFBP3709 | BOLT, FLANGE HEAD, 5/16"-18 X 1", GRADE 8, PLATED |

FENDER PARTS -- REAR

| BOM ID | Qty | Item No | Description |
|--------|-------|-------------|--|
| 1 | 5 | 1AEAP3548 | LAMP, SUPER 10 GROMMET, 10700-3 |
| 2 | 1 | 1AEAP4120 | LISCENSE PLATE LAMP, CLEAR, 12V |
| 3 | 1 | 1AEAP4121 | LISCENSE PLATE LAMP MTG BRACKET, GREY |
| 4 | 1 | 1AEAP4301 | ABS LIGHT BRACKET, 102008HP |
| 5 | 1 | 1AEAP4302 | ABS LIGHT, 101731F |
| 6 | 5 | 1AEAP4310 | LAMP, LED, CLEAR/MARKER, RED, 2-1/2" |
| 7 | 6 | 1AEL0607003 | MIDSHIP LIGHT GROMMET |
| 8 | 6 | 1AEL6050000 | RED 6" OVAL-LED |
| 9 | 2 | 1AF009D0000 | WASHER, FLAT, 1/4", PLTD |
| 10 | 4 | 1AF009F0000 | WASHER, FLAT, 3/8", PLTD |
| 11 | 4 | 1AF009H0000 | WASHER, FLAT, 1/2", PLTD |
| 12 | 2 | 1AFBP3587 | 1/4" NYLOCK NUT |
| 13 | 2 | 1AFBP3600 | HEX CAP SCREW, 1/4-20 X 1 GRD 8, PLTD |
| 14 | 30 | 1AFBP3612 | NUT, HEX LOCK, 3/8-16, TOP LOCK |
| 15 | 2 | 1AFBP3642 | PAN HEAD MACHINE SCREW, #10-24 X 3/4" |
| 16 | 2 | 1AFBP3643 | WASHER, #10 USS FLAT Z |
| 17 | 4 | 1AFBP3687 | BOLT, CARRIAGE, 3/8-16 X 4, GRD 5, PLTD |
| 18 | 18 | 1AFBP3692 | BOLT, FLNG HEAD, 3/8-16 X 1, GRD 8, PLTD |
| 19 | 4 | 1AFC12FAA05 | HEX CAP SCREW, 3/8"-16 X 1", GRD 5, PLTD |
| 20 | 4 | 1AFC12HAAH0 | HEX CAP SCREW, 1/2"-13 X 1-1/2", GRD 5, PLTD |
| 21 | 2 | 1AFC18C0000 | NYLON INSERT LOCKNUT, 10-24 UNC, ZINC |
| 22 | 4 | 1AFC18H0000 | 1/2" NYLOCK NUT |
| 23 | 4.16' | 1AQAS000000 | RWR CONSPICUITY TAPE |
| 24* | 1 | 1AU00000804 | MUDFLAP, DEMCO, 24" X 30" |
| 25 | 1 | 3CAM9008 | BACK COVER, ID LIGHTS |
| 26 | 2 | 3CAM9010 | BRACKET, FENDER MOUNT |
| 27 | 2 | 3CAM9011 | SPACER TUBE |
| 28 | 2 | 3CAM9035 | MUDFLAP BACKING STRAP |
| 29 | 1 | 3CAM9058 | ID LIGHT FACE PLATE |
| 30 | 1 | 5C000181 | FENDER / MUDFLAP MOUNT, LH, (DRIVER'S SIDE) |
| 31 | 1 | 5C000182 | FENDER / MUDFLAP MOUNT, RH, (PASSENGER SIDE) |

*Shown with optional Demco Mudflap.

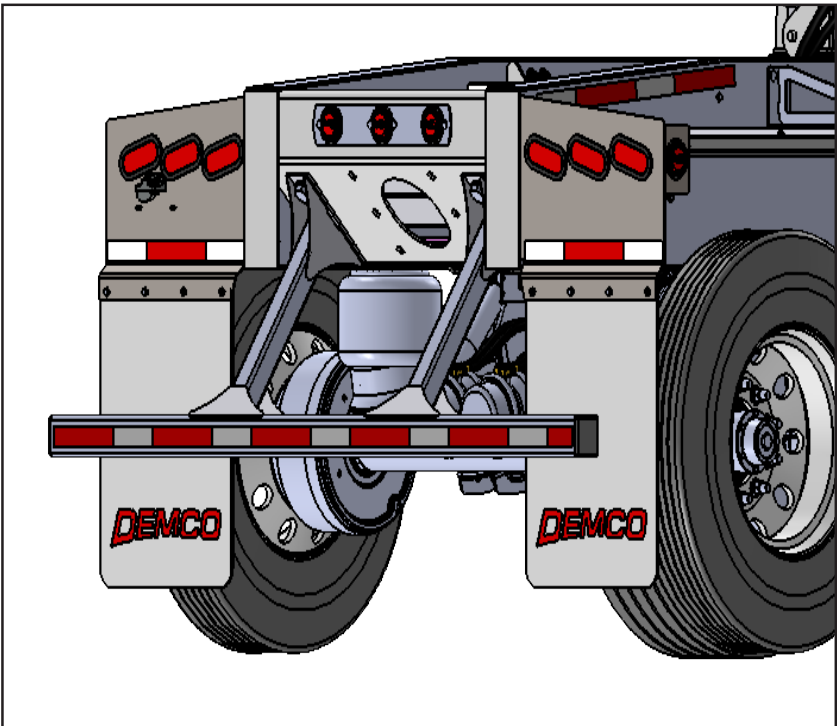
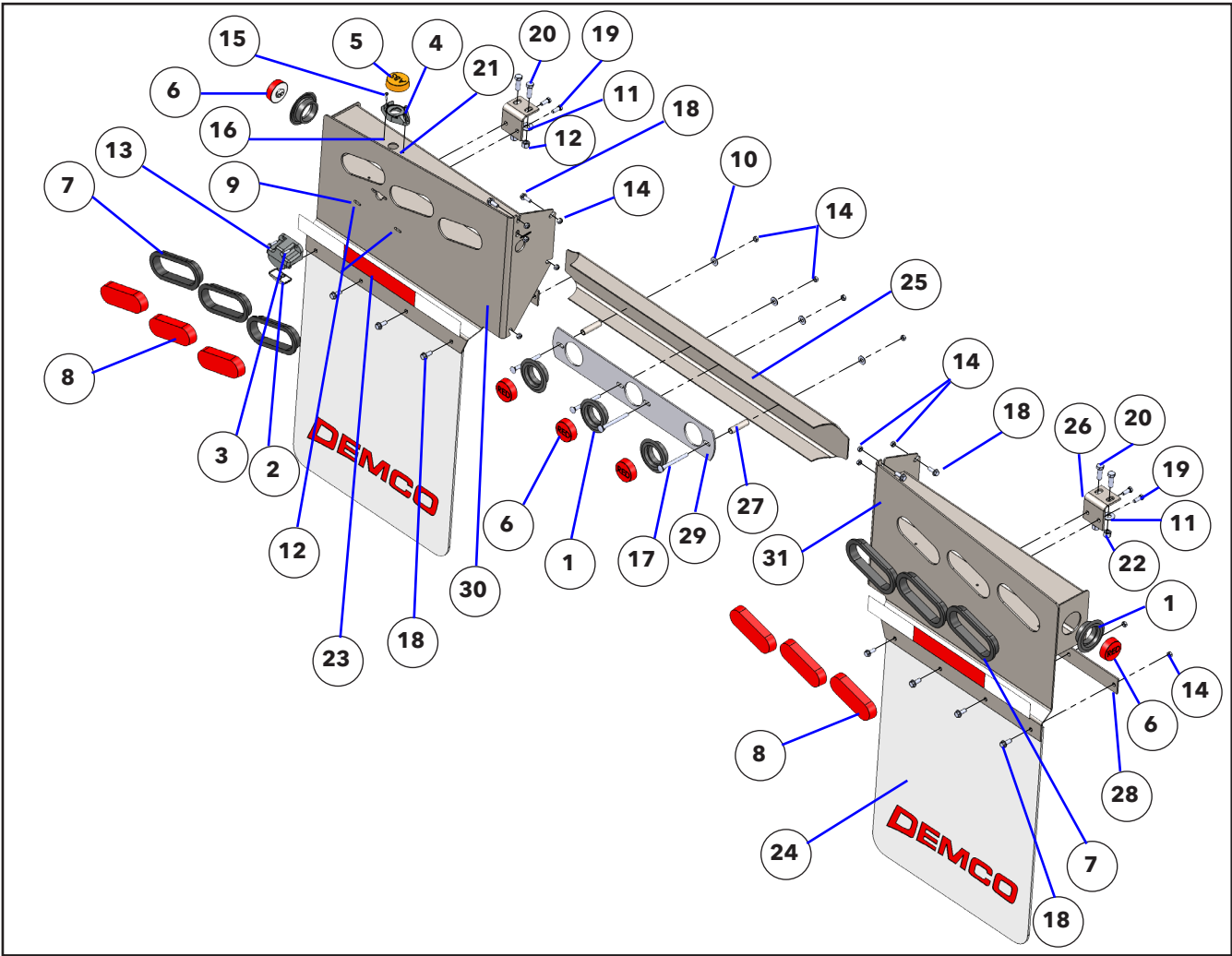

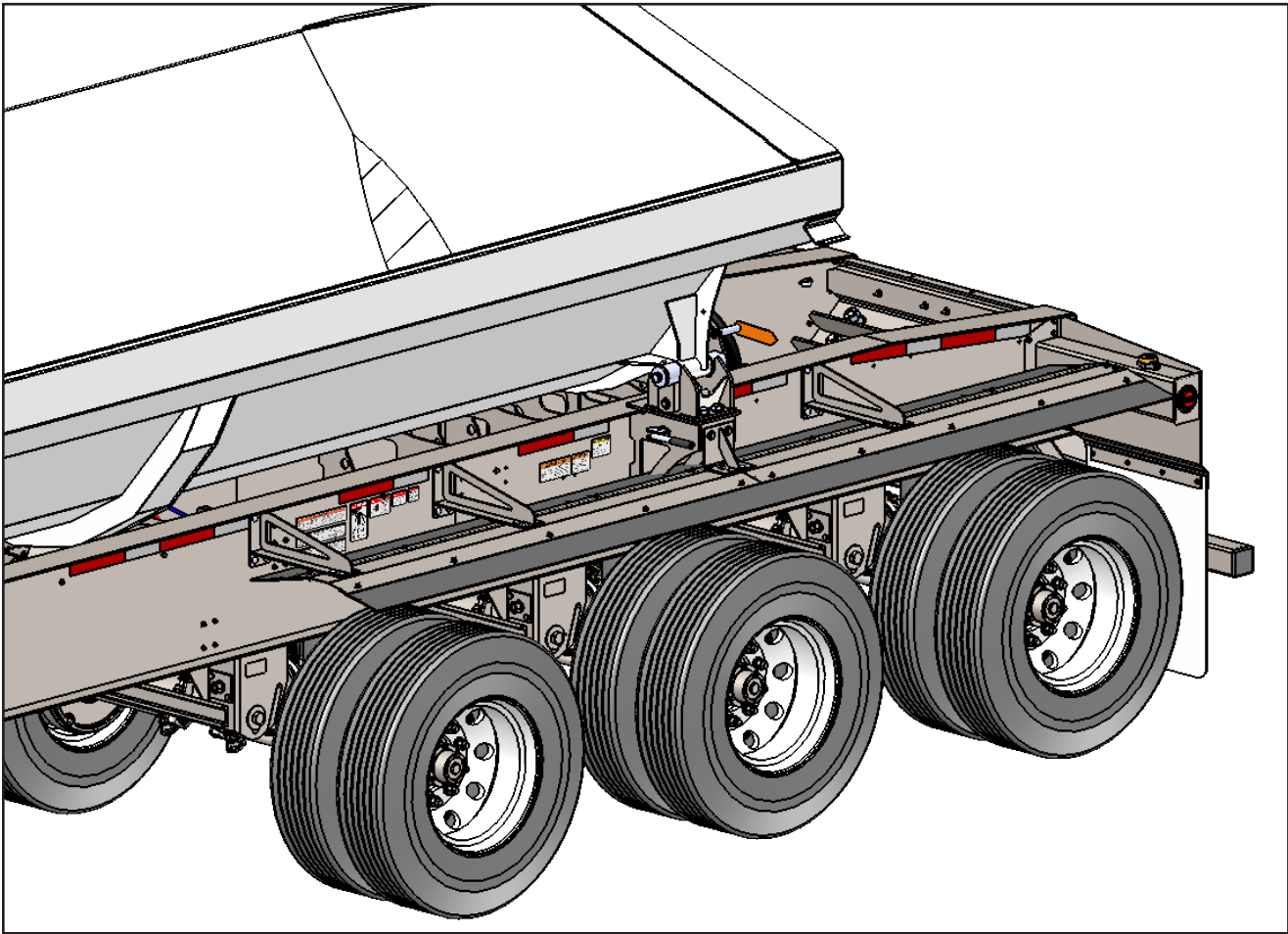
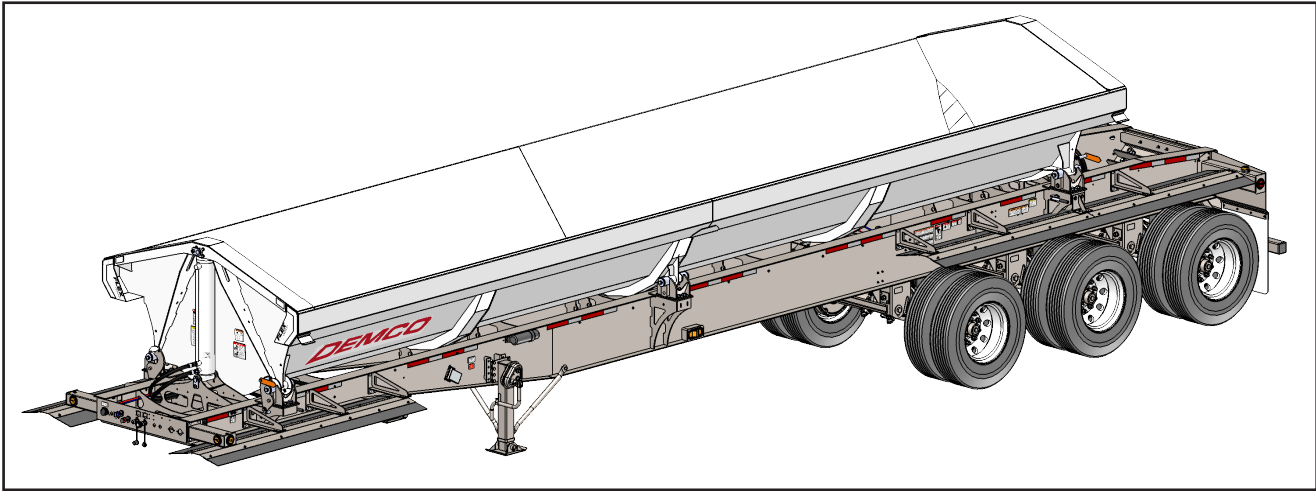

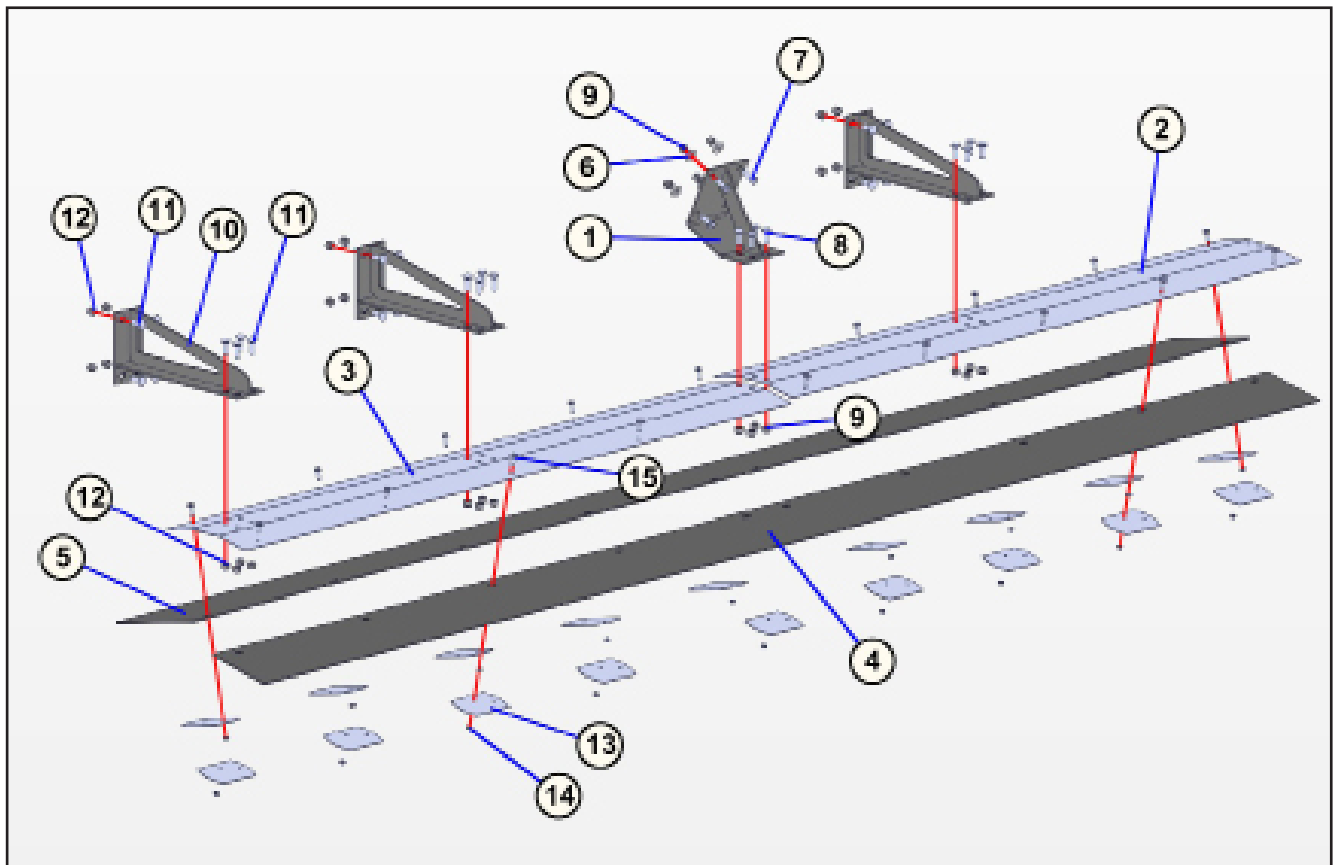

| BOM ID | Qty | Item No | Description |
|--------|-----|------------|---|
| 1 | 2 | 5CAM9003 | SADDLE FENDER MOUNT |
| 2 | 2 | 3CAM9449-1 | FENDER SUPPORT, REAR, SPREAD, 77-1/8" |
| 3 | 2 | 3CAM9450-1 | FENDER SUPPORT, REAR, SPREAD, 83" |
| 4 | 2 | 3CAM9451 | FENDER RUBBER, REAR, 8", SPREAD TRI |
| 5 | 2 | 3CAM9452 | FENDER RUBBER, REAR, 10', SPREAD TRI |
| 6 | 8 | 1AFBP3050 | WASHER, FLAT, 1/2", PLATED |
| 7 | 8 | 1AFBP3126 | HEX CAP SCREW, 1/2"-13 X 1-1/2", GRADE 5, PLATED |
| 8 | 8 | 1AFBP3232 | BOLT, CARRIAGE, 1/2"-13 X 1-1/2", GRADE 5 |
| 9 | 16 | 1AFBP3704 | NUT, LOCK, NYLON INSERT, 1/2"-13 |
| 10 | 6 | 5CAM9004 | FRAME FENDER MOUNT |
| 11 | 48 | 1AFBP3232 | BOLT, CARRIAGE, 1/2"-13 X 1-1/2", GRADE 5 |
| 12 | 48 | 1AFBP3704 | NUT, LOCK, NYLON INSERT, 1/2"-13 |
| 13 | 36 | 3CAM9089 | FENDER WASHER |
| 14 | 36 | 1AFBP3644 | NUT, HEX LOCK, 5/16"-18, TOP LOCK |
| 15 | 36 | 1AFBP3709 | BOLT, FLANGE HEAD, 5/16"-18 X 1", GRADE 8, PLATED |

(QUANTITIES ARE FOR A SET OF 2 FENDERS)

FIFTH WHEEL GREASE COMPONENTS

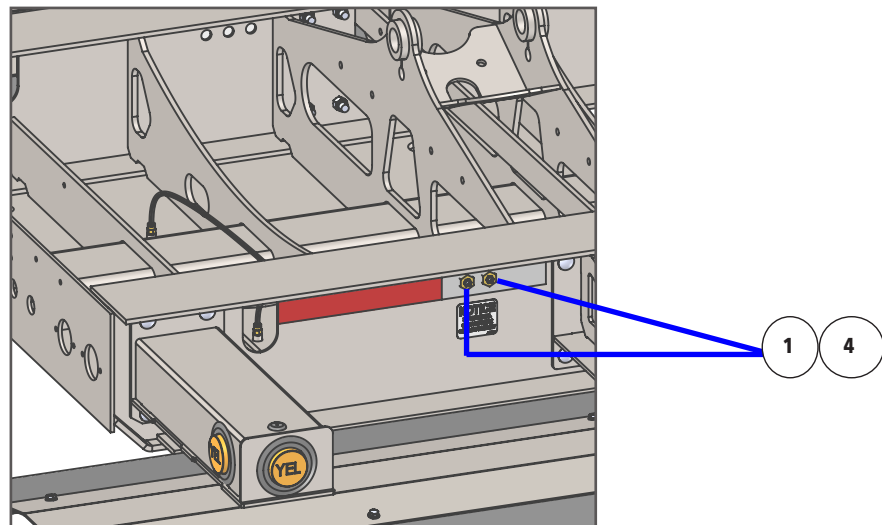
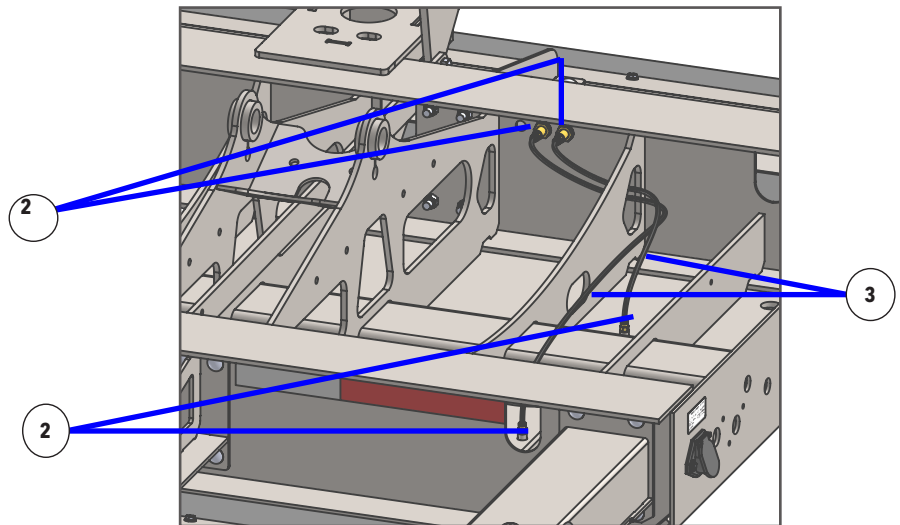

| BOM ID | Qty | Item No | Description |
|--------|-------|-------------|--|
| 1 | 2 | 1ABAP3423 | BULKHEAD ADAPTER, 1/8 FPT - 1/8 FPT |
| 2 | 4 | 1ABAP3426 | ADAPTER, 1/4" TUBE X 1/8 MPT, STRAIGHT |
| 3 | 4.63' | 1ABAP3685 | NYLON TUBING, BLACK, 1/4" |
| 4 | 2 | 1AKZAAA0000 | GREASE ZERK, 1/8" NPT |

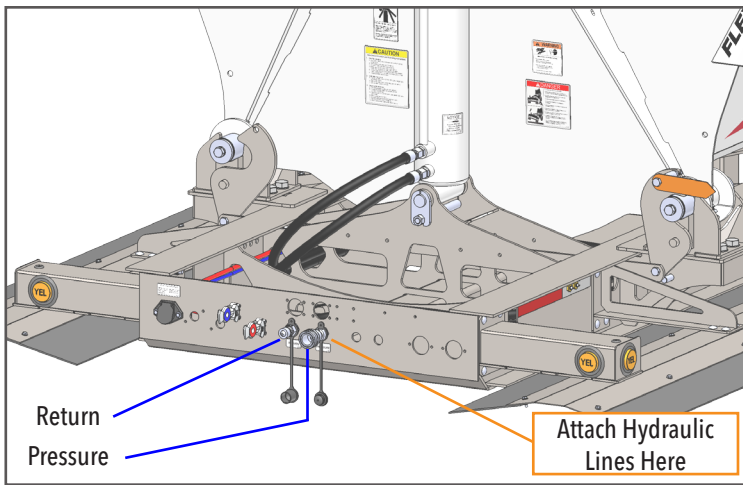

WARNING: Hydraulic fluid escaping under pressure can have enough force to penetrate the skin. Hydraulic fluid may also infect a minor cut or opening in the skin. If injured by escaping fluid, see doctor at once. Serious infection or reaction can result if medical treatment is not given immediately. Make sure all connections are tight and that hoses and lines are in good condition before applying pressure to the system. Relieve all pressure before disconnecting the lines or performing other work on the hydraulic systems.

Truck-Tractor Hydraulic Systems

Efficient, safe operation of side dump trailers require that the tractor hydraulic system provide a clean, high pressure, high volume oil supply. The hydraulic pump pressure should be set at 2500 PSI with a minimum output of 25 GPM supply and a minimum 15 gallon filtered and strained reservoir.

NOTE:

Hydraulic Oil Filter should be Changed every 25,000 miles or yearly, which ever comes first and hydraulic system flushed every 50,000 miles with pressure and flow rates checked.

Generic Tractor Hydraulic System

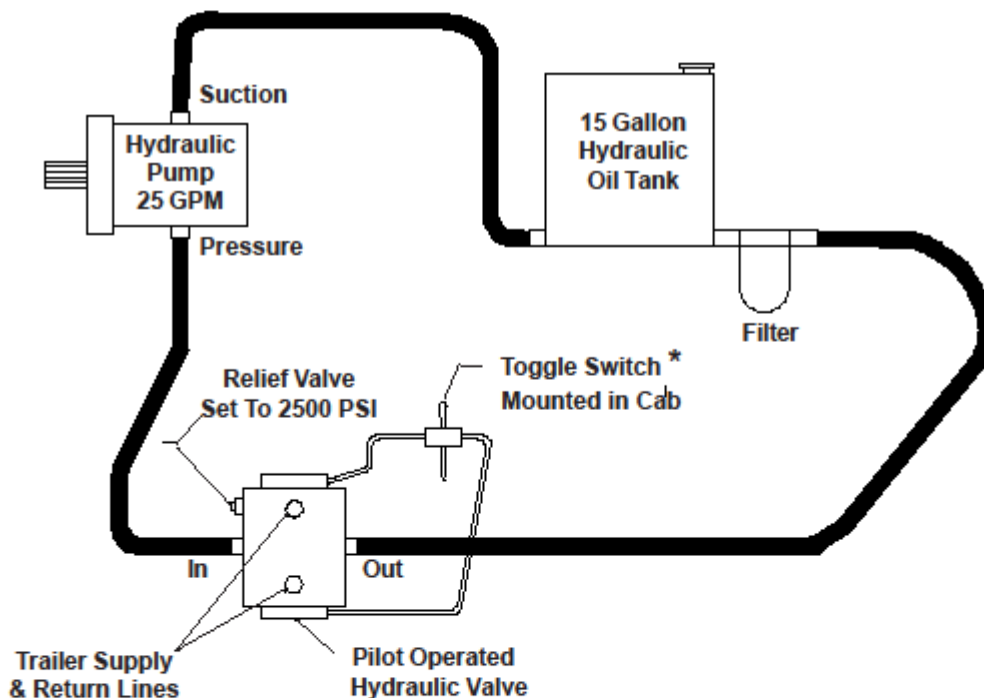

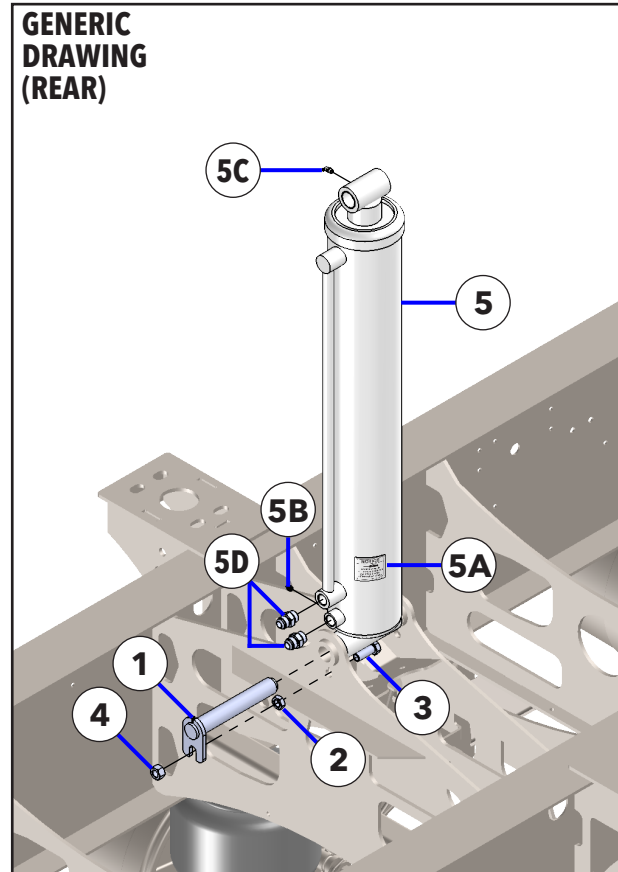
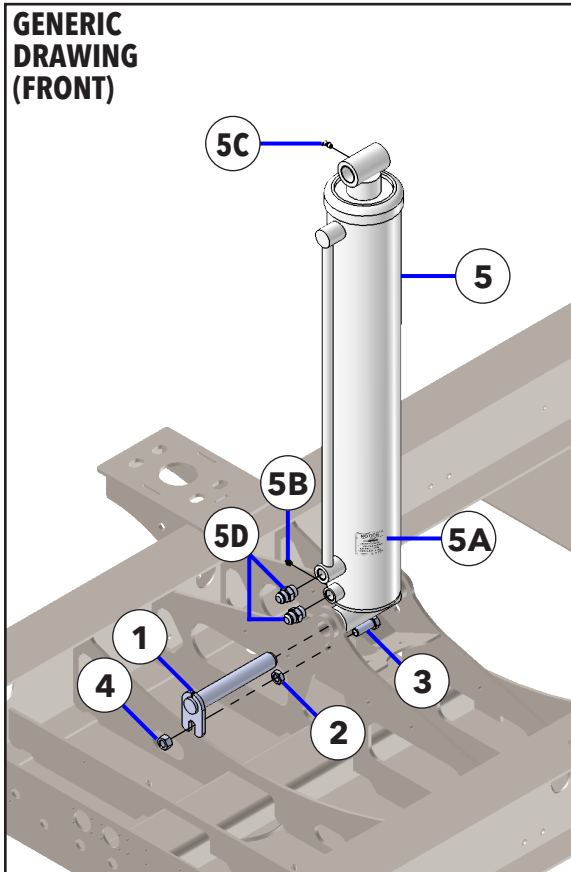

| BOM ID | Qty | Item No | Description |
|--------|-----|-------------|---|
| 1 | 2 | 5CAM9019 | PIN, CYLINDER, 1-1/2" X 9-5/8" |
| 2 | 2 | 1AFBP3107 | NUT, HEX JAM, 3/4"-10, GR 2, PLATED |
| 3 | 2 | 1AFBP3139 | HEX CAP SCREW, 3/4"-10 X 2", GR 5, PLATED |
| 4 | 2 | 1AFC05L0005 | 3/4 CENTERLOCK NUT |
| 5 | 2 | 1AYDP6347 | CYLINDER, HYDRAULIC, 5" X 36", WITH DROP TUBE |
| 5 | 2 | 1AYDP6349 | CYLINDER, HYDRAULIC, 6" X 36", WITH DROP TUBE |
| 5A | 2 | 1AQAP2986 | DECAL, GREASE TRAILER WEEKLY, 2-3/4"W X 3"T |
| 5B | 2 | 1AKZAAA0000 | GREASE ZERK, 1/8" NPT |
| 5C | 2 | 1AFBP3654 | GREASE ZERK, 1/8" MP X 45 DEGREE ELBOW |
| 5D | 4 | 1AKDP4368 | ADAPTER, 12MJIC-12MSAE, STRAIGHT, 6400-12 |
| * | 1 | 1AKDP6603 | SEAL KIT 5" WETHERELL CYLINDER |
| * | 1 | 1AKDP6569 | SEAL KIT 6" WETHERELL CYLINDER |

***Not shown in part diagrams.**

(5C090018) STANDARD HYDRAULIC PKG, SET BACK 34' TUB

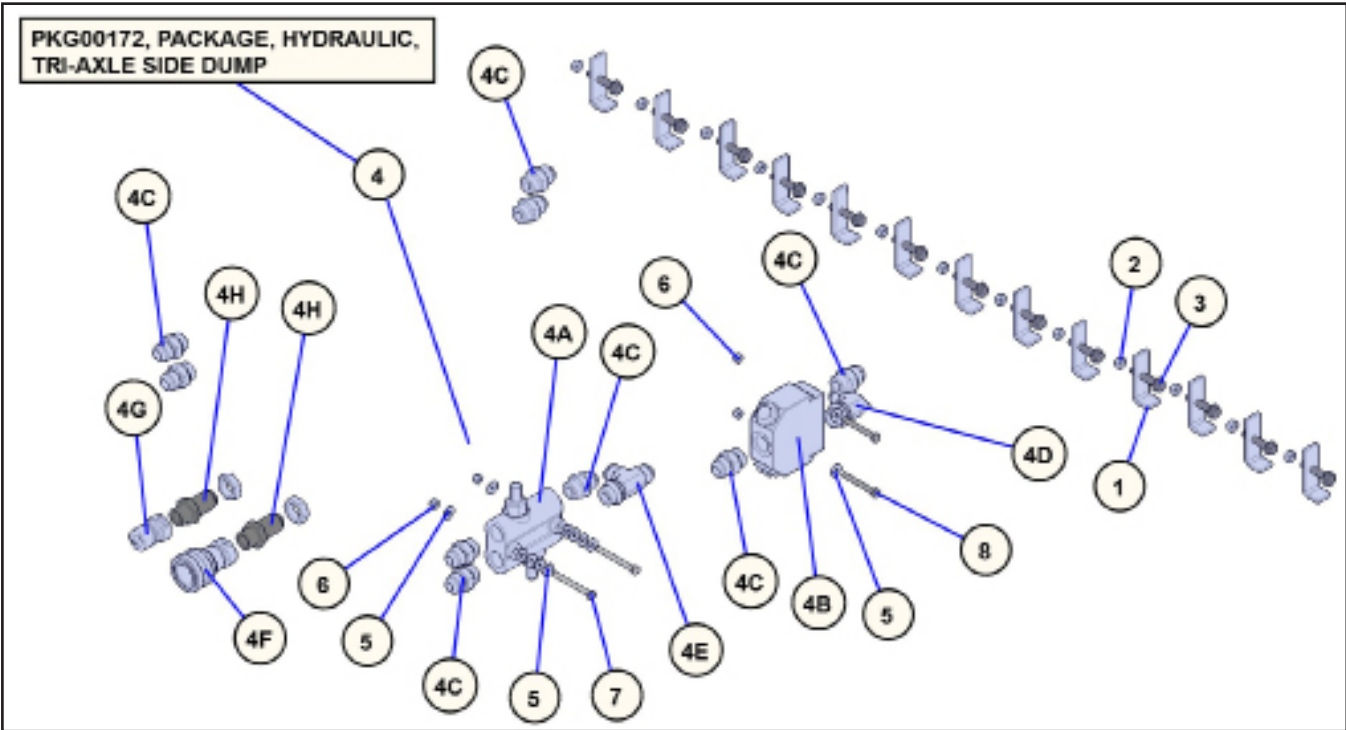

| BOM ID | Qty | Item No | Description |
|--------|-----|------------|---|
| 1 | 13 | 3CAM8053 | HOSE RETAINER, SINGLE |
| 2 | 13 | 1AFBP3612 | NUT, HEX LOCK, 3/8"-16, TOP LOCK |
| 3 | 13 | 1AFBP3685 | BOLT, FLANGE HEAD, 3/8"-16 X 2", GRADE 8, PLATED |
| 4 | 1 | 4CPKG00172 | PACKAGE, HYDRAULIC, TRI-AXLE SIDE DUMP |
| 4A | 1 | 1AKDP6302 | VALVE, DOUBLE RELIEF, PRINCE, H-L |
| 4B | 1 | 1AKDP6303 | VALVE, PROPORTIONAL DIVIDER, PRINCE |
| 4C | 9 | 1AKDP4368 | ADAPTER, 12MJIC-12MSAE, STRAIGHT, 6400-12 |
| 4D | 1 | 1AKDP6538 | ADAPTER, 12MJ-12MSAE 90 DEGREE, 6801-12 |
| 4E | 1 | 1AKDP6557 | TEE, 12MJ-12MSAE-12MJ, 6804-12 |
| 4F | 1 | 1ACDP6300 | COUPLER, QUICK, FEMALE, 3/4" NPT |
| 4G | 1 | 1ACDP6301 | COUPLER, QUICK, MALE, 3/4" NPT |
| 4H | 2 | 1AKDP6495 | BULKHEAD ADAPTER WITH NUT, 12MP-12MJ, 2706-LN-12-12 |
| 5 | 12 | 1AFBP3055 | WASHER, FLAT, 1/4", PLATED |
| 6 | 4 | 1AFBP3587 | NUT, HEX, 1/4" NYLOCK |
| 7 | 2 | 1AFBP3588 | HEX CAP SCREW, 1/4"-20 X 3", GRADE 8, PLATED |
| 8 | 2 | 1AFBP3589 | HEX CAP SCREW, 1/4"-20 x 2-1/2" GRADE 8 |

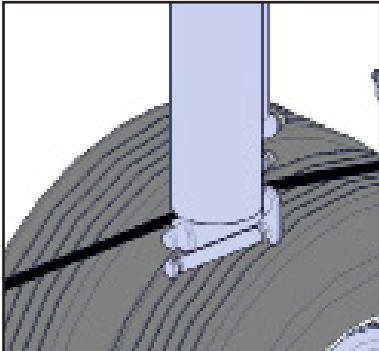
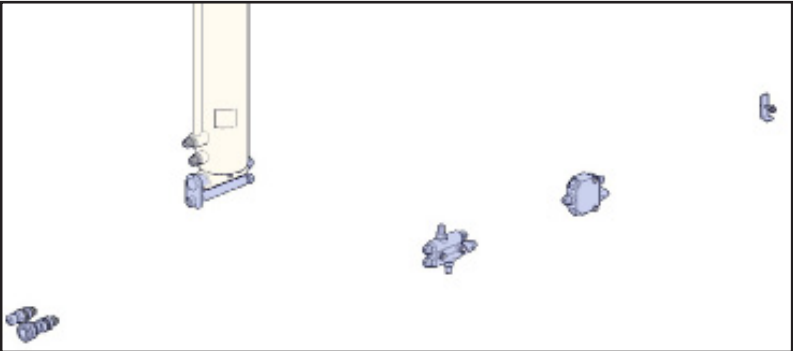

(1AKDDP1116) HOSE KIT, 34' TUB SET BACK

| BOM ID | Qty | Item No | Description |
|--------|-----|-----------|--|
| 1 | 2 | DP6349 | CYLINDER, HYDRAULIC, 6 X 36, WITH DROP TUBE |
| A | 1 | 1AKDP6527 | HOSE, HYDRAULIC, 3/4" X 460", 12FJX-12FJX |
| B | 1 | 1AKDP6528 | HOSE, HYDRAULIC, 3/4" X 435", 12FJX-12FJX |
| C | 1 | 1AKDP6529 | HOSE, HYDRAULIC, 3/4" X 130", 12FJX-12FJX |
| D | 1 | 1AKDP6530 | HOSE, HYDRAULIC, 3/4" X 125", 12FJX-12FJX |
| E | 1 | 1AKDP6547 | HOSE, HYDRAULIC, 3/4" X 68", 12FJX-12FJX |
| F | 1 | 1AKDP6547 | HOSE, HYDRAULIC, 3/4" X 68", 12FJX-12FJX |
| G | 1 | 1AKDP6558 | HOSE, HYDRAULIC, 3/4" X 18-1/2", 12FJX-12FJX |

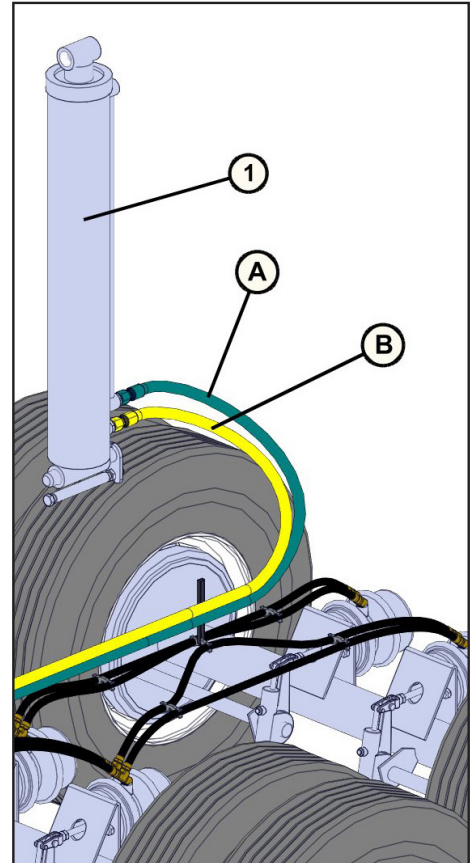
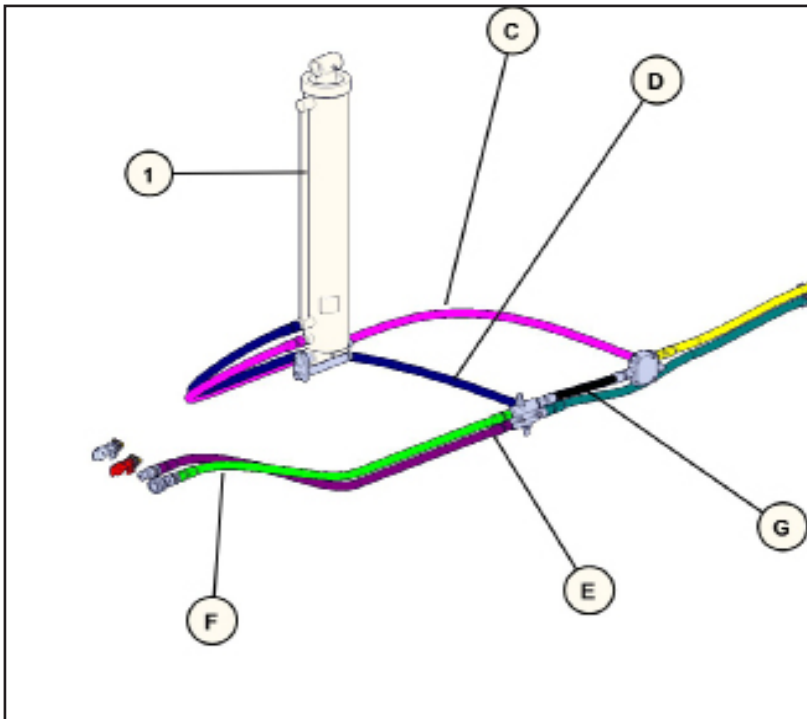
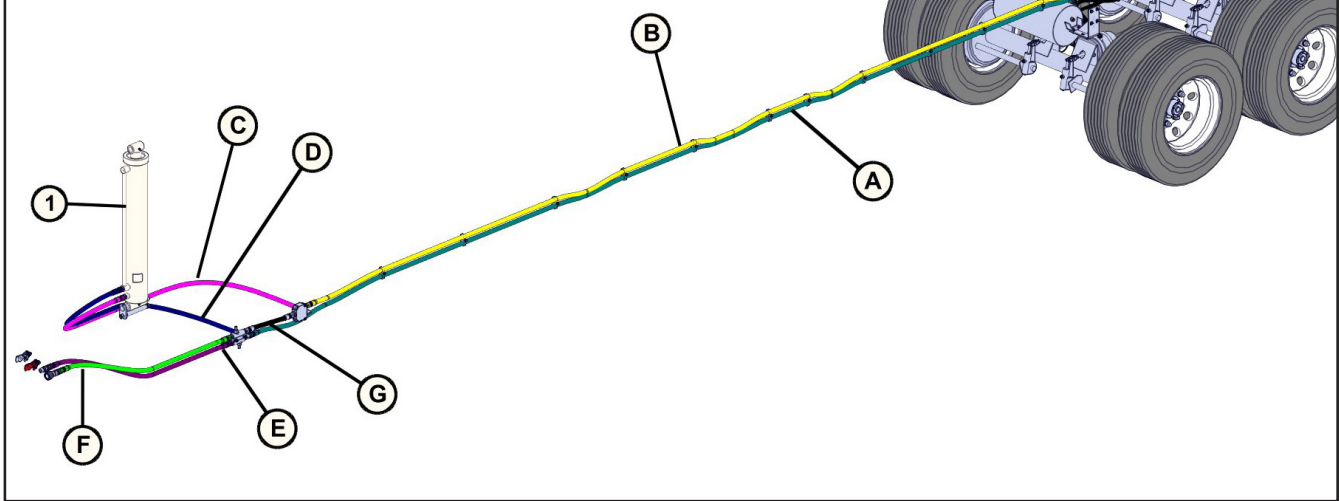
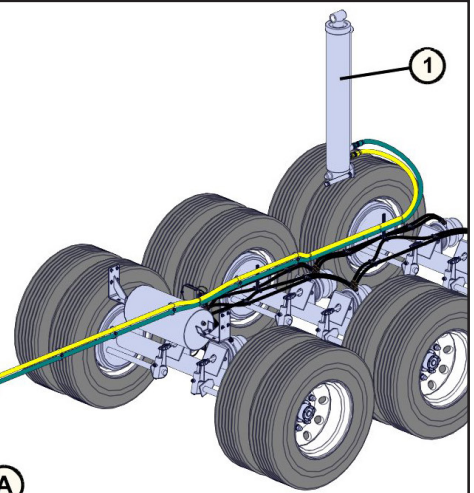

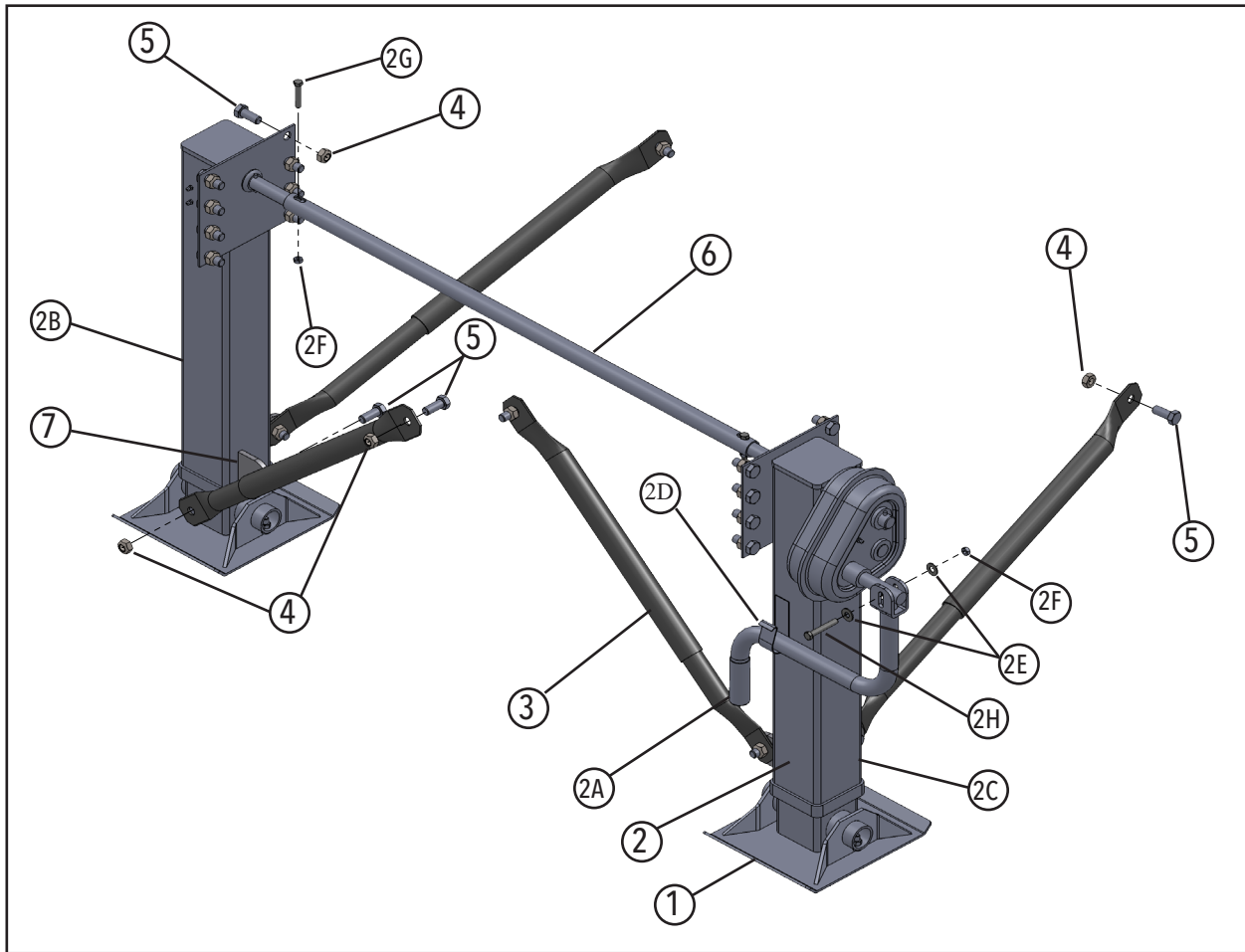

| BOM ID | Qty | Item No | Description |
|--------|-----|-------------|--|
| 1 | 1 | 4CPKG00112 | PACKAGE, JACK, 2001 SIDE DUMP |
| 2 | 1 | 1AJAP3503 | JACK, LANDING LEG AND GEAR SET |
| 2A | 1 | 1AJAP3504 | CRANK HANDLE |
| 2B | 1 | 1AJAP4098 | JACK LEG, CURB SIDE |
| 2C | 1 | 1AJAP4099 | JACK LEG, ROAD SIDE |
| 2D | 1 | 1AJAP4101 | CRANK HANDLE CLIP |
| 2E | 2 | 1AFBP3015 | WASHER, FLAT, 3/8", PLATED |
| 2F | 3 | 1AFBP3612 | NUT, HEX LOCK, 3/8"-16, TOP LOCK |
| 2G | 2 | 1AFBP3625 | HEX CAP SCREW, 3/8"-16 X 2", GRADE 8, PLATED |
| 2H | 1 | 1AFBP3626 | HEX CAP SCREW, 3/8"-16 X 2-1/2", GRADE 8, PLATED |
| 3 | 4 | 1ASAP3505 | ADJUSTABLE BRACE |
| 4 | 24 | 1AFBP3615 | NUT, HEX LOCK, 5/8"-11, GRADE 8, PLATED, UTC |
| 5 | 24 | 1AFBP3617 | HEX CAP SCREW, 5/8"-11 X 1-1/2", GRADE 8, PLATED |
| 6 | 1 | 1AU00000146 | CROSS SHAFT, SHORT |
| 7 | 4 | 3C000371 | JACK BRACE MOUNT TAB |

ATLAS 55 Standard - Exploded View

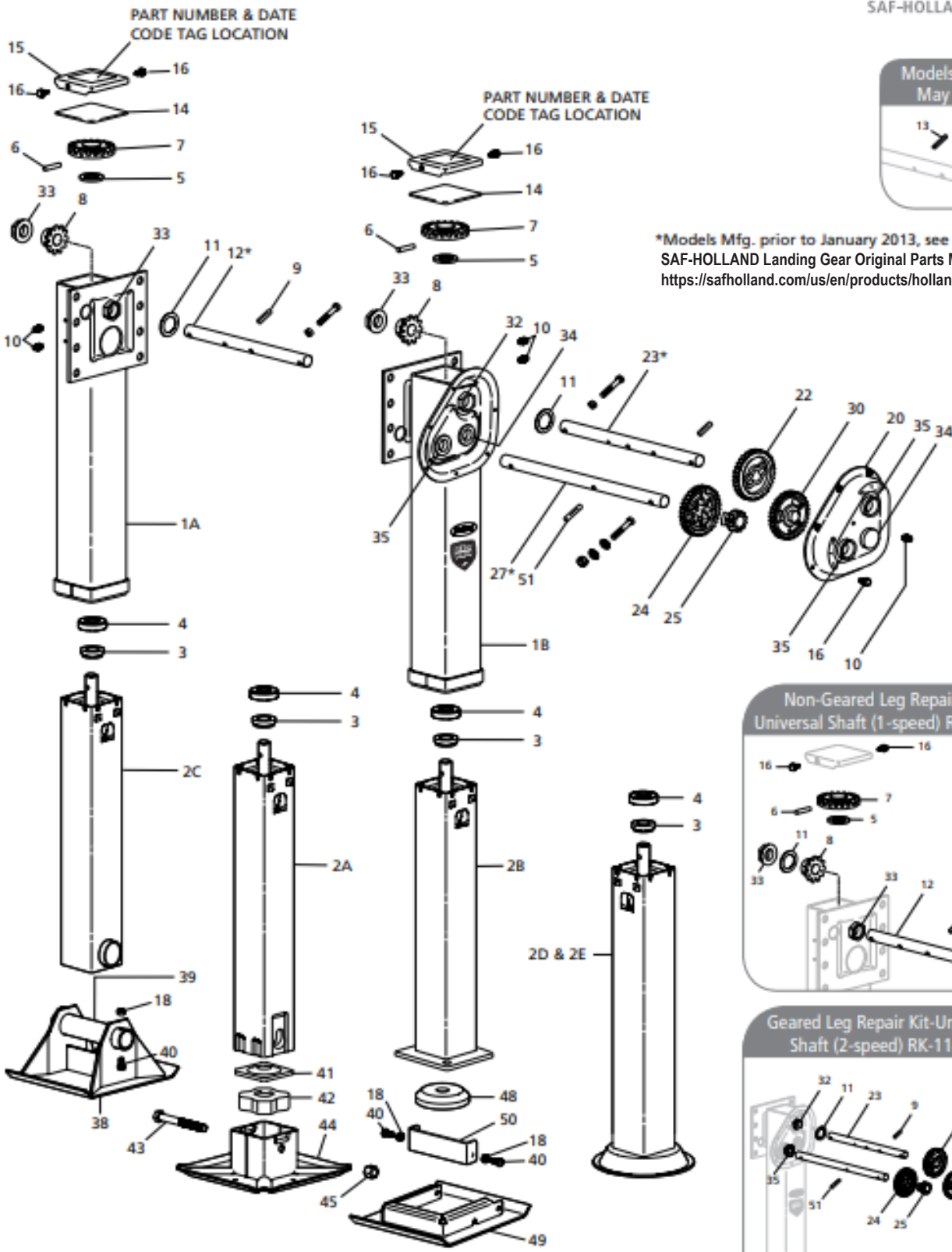

For a complete parts list or technical assistance, please go to www.safholland.us or call 800.876.3929

Parts List for Atlas 55 Standard and NoLube Landing Gear

| NO. | DESCRIPTION | RETRACT TUBE CODE | 17" TRAVEL STANDARD | 17" TRAVEL NOLUBE |
|-----|----------------------------------|-------------------|---------------------|-------------------|
| 2A | Retract Tube - RCF | 0 or 5 (MRL) | LG3053-04 | LG3071-04 |
| 2B | Retract Tube - Low Profe RCF | 0 | LG3097-03 | LG3097-13 |
| 2C | Retract Tube - Axle | 0 | LG3012-03 | LG3077-03 |
| 2D | Retract Tube - Shockfoot 10" DIA | 0, 6 (CAN) or B | LG3061-04 | LG3095-01 |
| 2E | Retract Tube - Shockfoot 12" DIA | 0, 6 (CAN) or B | LG3061-05 | LG3095-02 |

| NO. | DESCRIPTION | PART NO. | SPEED ONE | SPEED TWO |
|-----|--|----------------|-----------|-----------|
| 1A | Upper Housing LH | N/A | - | - |
| 1B | Upper Housing RH | N/A | - | - |
| 3 | Collar | XB-LG0544 | 1 | 1 |
| 4 | Thrust Bearing | XB-BRG-013-77 | 1 | 1 |
| 5 | Washer - FL 2" OD x 1.19" ID x .13" THK | XB-PW-016-62 | 1 | 1 |
| 6 | Pin - DIA .39" x 2" | XA-CRP-V-06635 | 1 | 2 |
| 7 | Bevel Gear | LG2884 | 1 | 1 |
| 8 | Pinion Gear | LG1823-02 | 1 | 1 |
| 9 | Groove Pin - DIA .38" x 1.50" | XB-GP-014-18 | 1 | 1 |
| 10 | Ftg - Grease .25" -28 Self-Tapping | XB-GRF-022-16 | 2 | 3 |
| 11 | O-Ring, #319 | 2024100000100 | 1 | 1 |
| 12 | Jack Shaft LH Universal Mount | LG2964-01 | 1 | - |
| 13 | Pin - Spring DIA .25" x 1.5" (Not Required) | N/A | - | - |
| 15 | Top Cover | 2111100004080 | 1 | 1 |
| 16 | Self-Tapping Screw .25" -20 x .5" Lg | XB-STS-008-11 | 2 | 9 |
| 17 | Screw, Hex Cap .38"-16 x 2.25" Lg GR5 | XB-HHC-050-42 | 1 | 2 |
| 18 | Self-Locking Nut .38"-16 - Sandshoe | XB-SLN-012-04 | 2 | 3 |
| 19 | Washer .38" Std Type A | XB-PW-016-03 | -- | 2 |
| 20 | Gearbox Half, Outside w/Hole for Grease Fitting | LG2996 | - | 1 |
| 22 | Output Gear | LG2980 | - | 1 |
| 23 | Jackshaft RH - Universal Mount | LG2963-01 | - | 1 |
| 24 | Gear, Drive, High Speed - Machined | 2040100000060 | - | 1 |
| 25 | Gear, Drive, Low Speed - Machined | 2040100000050 | - | 1 |
| 26 | Groove Pin, Type E DIA .38" x 2.00" Lg | XB-GP-052-21 | - | 1 |
| 27 | Shift Shaft - Universal | 2111100003400 | - | 1 |
| 30 | Idler Gear | LG2975 | - | 1 |
| 32 | Boss, Hex Lock - Oversized | 2022100000180 | - | 1 |
| 33 | Hex Lock Boss - Sealed | LG2926-10 | 2 | 1 |
| 34 | Idler Shaft Bushing (Included in Item #23) | LG3005 | - | 2 |
| 35 | Boss Bearing - Sealed (Included in Item #20) | LG0659-10 | - | 3 |
| 38 | Sandshoe - 10" x 12" x 2.00" | 50616007 | 1 | 1 |
| 39 | Sandshoe Axle - Hollow Axle 8.50" Lg | LG0070-02 | 1 | 1 |
| 40 | Screw, Hex Cap .38"-16 x .75" Lg GR5 - Sandshoe | XB-HHC-050-69 | 1 | 1 |
| | Screw, Hex Cap .38"-16 x .75" Lg GR5 - Low Profile RCF | XB-HHC-050-69 | 2 | 2 |
| 41 | Foot Plate | LG0725 | 1 | 1 |
| 42 | Foot Rubber | XB-LG0726 | 1 | 1 |
| 45 | Self-Locking Nut - .63-11" | XB-SP0012-10 | 1 | 1 |
| 48 | Foot Pad - Low Profile RCF | 728003 | 1 | 1 |
| 49 | Interchangeable Collar - Low Profile RCF | 730640 | 1 | 1 |
| 50 | Interchangeable Strap | 730638 | 1 | 1 |
| 51 | Pin Groove, .31" Dia x 2.00" Lg | XB-GP-052-52 | - | 1 |

PIVOT LATCH COMPONENTS

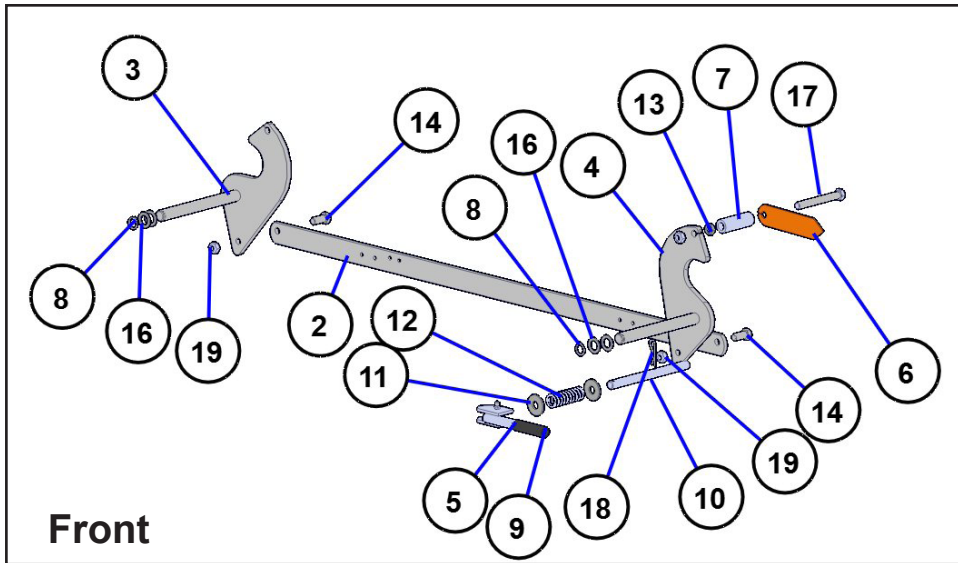

| BOM ID | Qty | Item No | Description |
|--------|-----|------------|--|
| 1 | 1 | 4CPKG00113 | PACKAGE, PIVOT LATCH, 2001 SIDE DUMP |
| 2 | 2 | 3CAM9078 | LATCH CONNECTOR |
| 3 | 2 | 5CAM9123 | TUB PIVOT LOCK, LEFT HAND FRONT/RIGHT HAND REAR |
| 4 | 2 | 5CAM9124 | TUB PIVOT LOCK, RIGHT HAND FRONT/ LEFT HAND REAR |
| 5 | 2 | 3CAM9125 | LATCH LOCK HANDLE |
| 6 | 2 | 3CAM9155 | LATCH INDICATOR FLAG |
| 7 | 2 | 3CAM9156 | SPACER |
| 8 | 4 | 1AFAP2407 | SNAP RING, 1" EXTERNAL, HEAVY DUTY |
| 9 | 2 | 1ABAP4208 | GRIP, .843" ID X 4" OAL |
| 10 | 2 | 1AFBM3727 | PIN, LATCH LOCK, 3/4" X 10-3/8" OAL |
| 11 | 4 | 1AFBP3033 | WASHER, FLAT, 3/4", PLATED, STANDARD, TYPE A, SERIES W |
| 12 | 2 | 1AFBP3066 | COMPRESSION SPRING RIGID HITCH |
| 13 | 2 | 1AFBP3080 | NUT, HEX JAM, 5/8"-11, GRADE 2 |
| 14 | 4 | 1AFBP3097 | HEX CAP SCREW, 5/8"-11 X 1-1/2", GRADE 5, PLATED |
| 15 | 2 | 1AFBP3110 | HEX CAP SCREW, 5/16"-18 X 2", GRADE 5, PLATED |
| 16 | 8 | 1AFBP3215 | MACHINERY BUSHING, 1-1/2" OD X 1" ID, 14 GAUGE, PLATED |
| 17 | 2 | 1AFBP3298 | HEX CAP SCREW, 5/8"-11 X 5-1/2", GRADE 5, PLATED |
| 18 | 2 | 1AFBP3504 | PIN, HAIRCLIP, 1/8" |
| 19 | 6 | 1AFBP3615 | NUT, HEX LOCK, 5/8"-11, GRADE 8, PLATED |
| 20 | 2 | 1AFBP3644 | NUT, HEX LOCK, 5/16"-18, TOP LOCK |

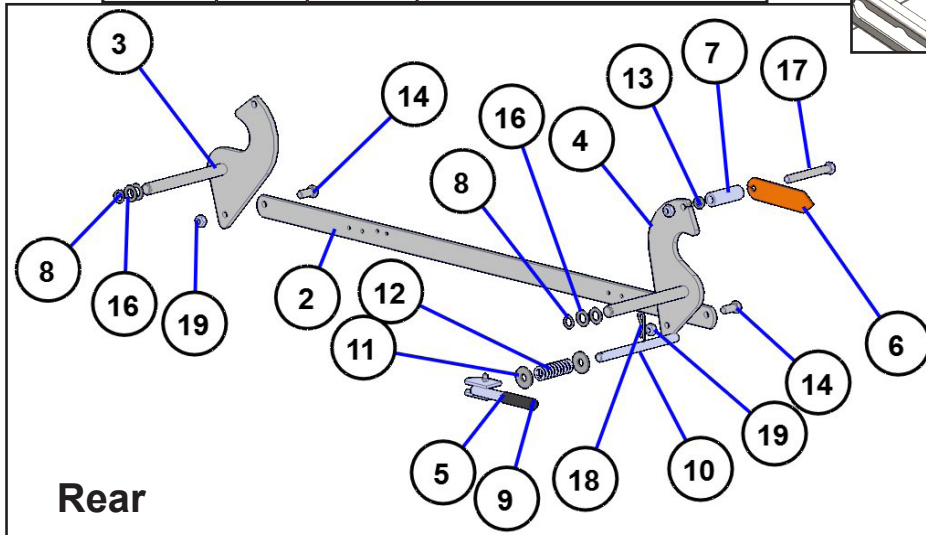
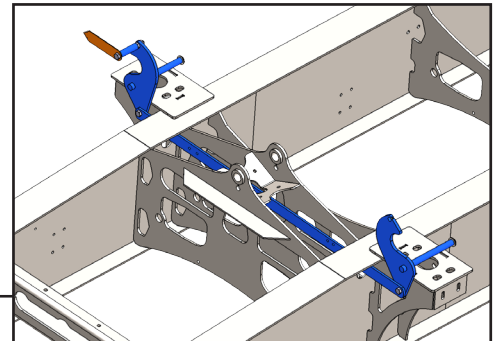
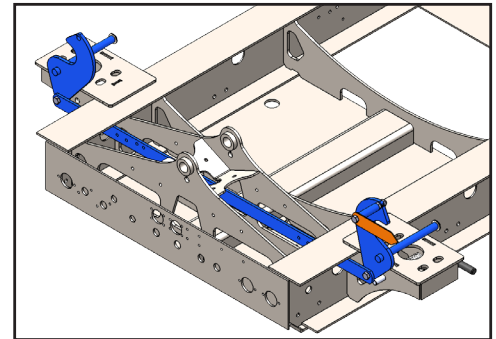

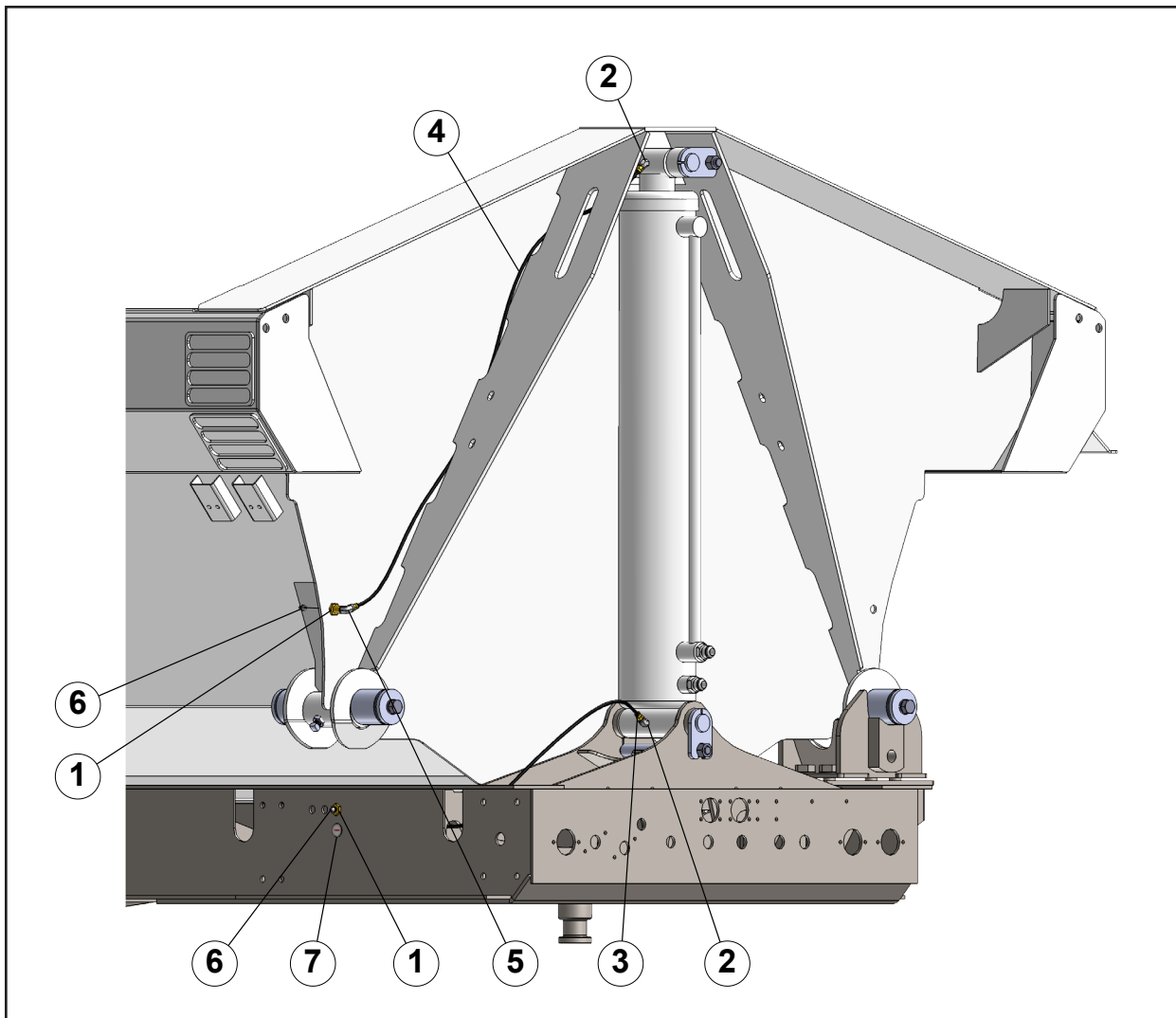

| BOM ID | Qty | Item No | Description |
|--------|-----|-------------|--|
| 1 | 4 | 1AFBP3423 | BULKHEAD FITTING, 1/8" FNPT - 1/8" FNPT |
| 2 | 4 | 1AKEABAAAA0 | 45 DEG ELBOW ADAPTER, 1/8" FNPT X 1/8" MNPT |
| 3 | 2 | 1AKHAAAAA0 | 1/8" X 50" GREASE HOSE, 1/8" MNPT RIGID X 1/8" MNPT SWIV |
| 4 | 2 | 1AKHAAAAA1 | 1/8" X 60" GREASE HOSE, 1/8" MNPT RIGID X 1/8" MNPT SWIV |
| 5 | 2 | 1AKLABAAAA0 | 90 DEG ELBOW ADAPTER, 1/8" FNPT - 1/8" MNPT |
| 6 | 4 | 1AKZAAA0000 | 1/8"-27 GREASE ZERK, STRAIGHT, PLTD |
| 7 | 4 | 1AQBC015065 | DECAL, GREASE GUN, RED ON WHITE |

Important: Install new safety decals and reflectors if the old decals and reflectors are destroyed, lost, painted over or cannot be read. When parts are replaced that have decals or reflectors, make sure you install a new decal with each new part.

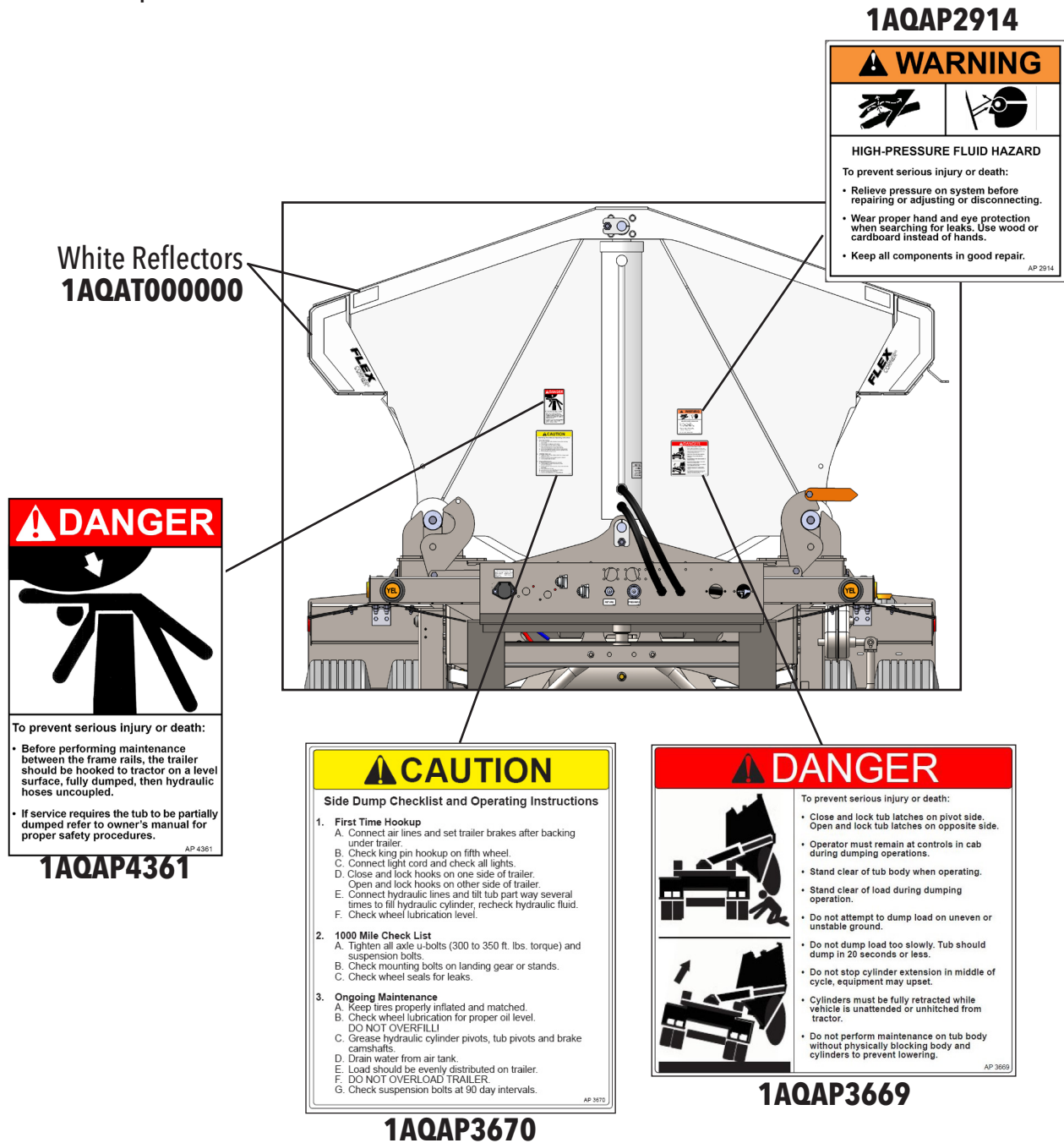

DANGER

To prevent serious injury or death:

- Before performing maintenance between the frame rails, the trailer should be hooked to tractor on a level surface, fully dumped, then hydraulic hoses uncoupled.
- If service requires the tub to be partially dumped refer to owner's manual for proper safety procedures.

AP-4361

CAUTION

Side Dump Checklist and Operating Instructions

- First Time Hookup**
 - Connect air lines and set trailer brakes after backing under trailer.
 - Check king pin hookup on fifth wheel.
 - Connect light cord and check all lights.
 - Close and lock hooks on one side of trailer. Open and lock hooks on other side of trailer.
 - Connect hydraulic lines and tilt tub part way several times to fill hydraulic cylinder, recheck hydraulic fluid.
 - Check wheel lubrication level.
- 1000 Mile Check List**
 - Tighten all axle u-bolts (300 to 350 ft. lbs. torque) and suspension bolts.
 - Check mounting bolts on landing gear or stands.
 - Check wheel seals for leaks.
- Ongoing Maintenance**
 - Keep tires properly inflated and matched.
 - Check wheel lubrication for proper oil level.
DO NOT OVERFILL!
 - Grease hydraulic cylinder pivots, tub pivots and brake camshafts.
 - Drain water from air tank.
 - Load should be evenly distributed on trailer.
 - DO NOT OVERLOAD TRAILER.**
 - Check suspension bolts at 90 day intervals.

AP-3670

DANGER

To prevent serious injury or death:

- Close and lock tub latches on pivot side. Open and lock tub latches on opposite side.
- Operator must remain at controls in cab during dumping operations.
- Stand clear of tub body when operating.
- Stand clear of load during dumping operation.
- Do not attempt to dump load on uneven or unstable ground.
- Do not dump load too slowly. Tub should dump in 20 seconds or less.
- Do not stop cylinder extension in middle of cycle, equipment may upset.
- Cylinders must be fully retracted while vehicle is unattended or unhitched from tractor.
- Do not perform maintenance on tub body without physically blocking body and cylinders to prevent lowering.

AP-3669

- 1AQAP3669 (1) DANGER (Load Dumping Safety) 8"W x 5-1/2"L**
- 1AQAP3670 (1) CAUTION (Side Dump Checklist and Operating Instructions) 6"W x 7"L**
- 1AQAP2914 (1) WARNING (High Pressure Fluid) 4"W x 4"L**
- 1AQAP4361 (2) DANGER (Frame Area Maintenance) 3"W x 6-1/4"L**
- *1AQAT000000 (4) White Conspicuity Tape, 2" Wide**

***White Conspicuity Tape is located at both sides of both ends of tub.**

NOTE: New decals and reflectors are available from your dealer.

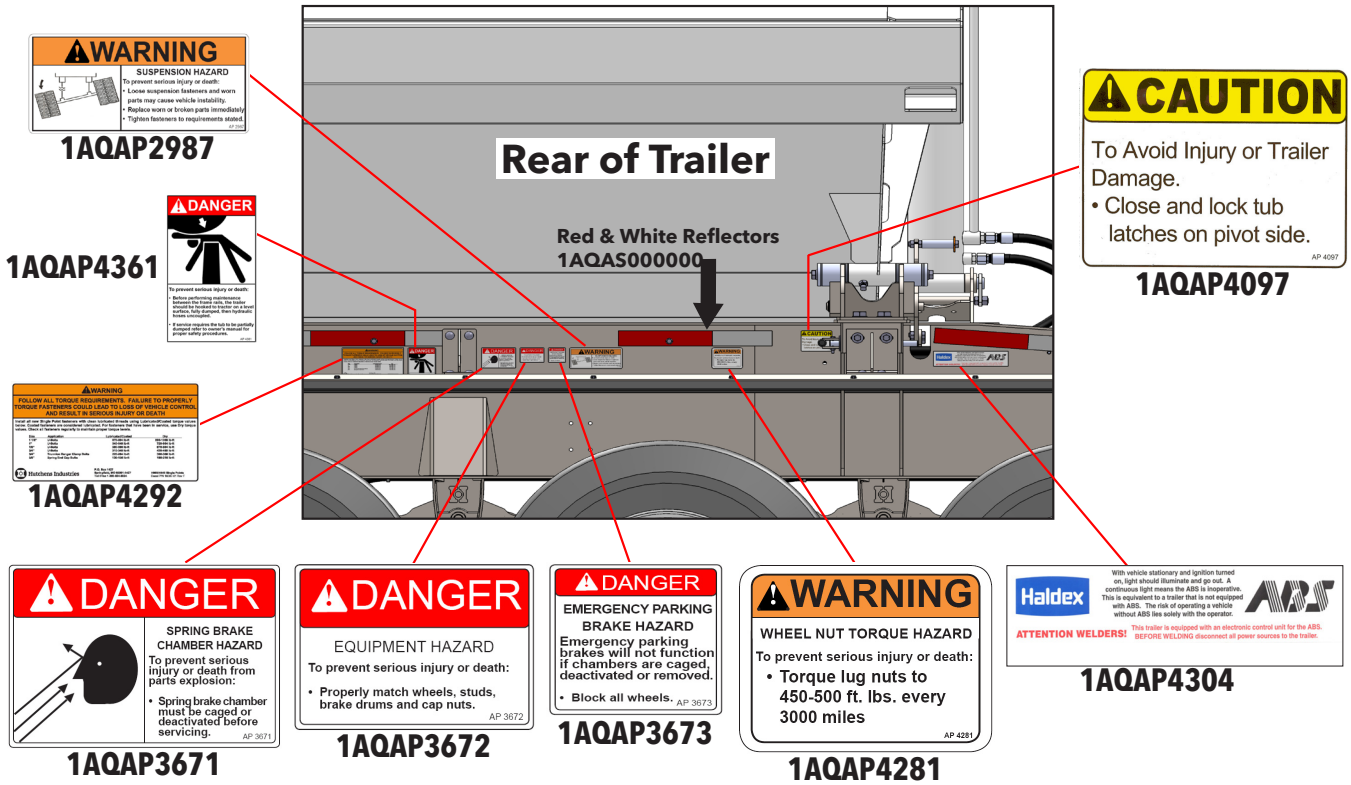

IMPORTANT:

Install new safety decals and reflectors if the existing decals and reflectors are destroyed, lost, painted over, or cannot be read. When parts are replaced that have decals or reflectors, make sure you install a new decal with each new part.

- 1AQAP2987 (1) Decal, **WARNING**, Suspension Hazard
- * 1AQAP3673 (2) Decal, **DANGER** Emergency Parking Brake Hazard
- * 1AQAP3672 (2) Decal, **DANGER** Equipment Hazard
- * 1AQAP3671 (2) Decal, **DANGER** Spring Brake Chamber Hazard
- 1AQAP4097 (2) Decal, **CAUTION**, lock tub latches
- 1AQAP4281 (1) Decal, **WARNING**, Wheel Nut Torque
- † 1AQAP4292 (1) Decal, Hutch Suspension Torque, Orange/Black
- 1AQAP4304 (1) Decal, Haldex ABS Light/ATTN Welders
- 1AQAP4361 (2) Decal, Frame Area Maintenance, Trailer
- † 1AQAP4556 (1) Decal, Holland CBX Swing Align Instruction
- † 1AQAP4557 (1) Decal, Holland CBX Torque Specs

KEY:

- * Safety decals are located at the rear of the trailer on both sides.
- † Spring Ride Trailers only.
- ‡ Air Ride Trailers only.

HOW TO APPLY SAFETY DECALS:

1. Be sure that the installation area is clean and dry.
2. Be sure temperature is above 50°F(10°C).
3. Decide on exact position before removing the backing paper.
4. Remove smallest portion of split backing paper.
5. Align decal over specified area and carefully press the small portion with the exposed adhesive in place.
6. Slowly peel back remaining paper and carefully smooth remaining portions of decal into place.
7. Small air pockets can be pierced with a pin and smoothed out using a piece of decal backing paper.

SWING ALIGN / NON-WELDED AXLE ALIGNMENT PROCEDURES

ALIGNMENT BOLT IS ON THE FRONT OF THE ROADSIDE FRAME BRACKET:

STEP 1. To properly align the suspension, the trailer should be pulled to a straight line for a sufficient distance. In most cases are to back in the suspension.

STEP 2. Check to verify trailer is level and emergency brakes are NOT engaged.

STEP 3. Place bolt **CLOCKWISE** to move axle forward (A arrows), **COUNTERCLOCKWISE** to move axle rearward (B arrows).

ALIGNMENT BOLT TIGHT

NOTE: 1/2 inch of the play in either direction (A or B)

A ← axle forward
B → axle rearward

1AQAP4556

CBX / CB FIXED FRAME TRAILER AIR SUSPENSION TORQUE SPECIFICATIONS

Torques are with clean, lubricated threads. Always apply torque to nut, if possible.

| Fastener Size | Pivot Connection | Shock | Air Spring | Beefing/Align |
|-------------------|-------------------|-------------------|----------------|----------------|
| | 1/2" | 3/4" | 1/2" | 3/4" |
| Torque (ft.-lbs.) | 400-500 (800-675) | 140-175 (150-225) | 80-110 (84-84) | 80-110 (88-81) |

REQUIRED RE-TORQUING SCHEDULE:

- At tow-ins after first three (3) months or 5,000 miles.
- At every routine preventative maintenance.
- At every brake setting.

1AQAP4557

SUSPENSION PARTS -- CBX23 STANDARD

This trailer utilizes SAF-Holland parts including the following:

- A CBX/CB Series Fixed Frame Top Mount Trailer Air Suspension for Disc and Drum Brake Applications, CBX23-245 with 17" ride height
- A PosiLift Air Lift Fixed Frame CBX Series CB-2300 Series.

Sections of the SAF-Holland Original Quick Parts Reference Guide are included with permissions. For questions, please call 1-888-396-6501 or refer to online manuals at SAF-Holland's website: <https://safholland.com/us/en/>

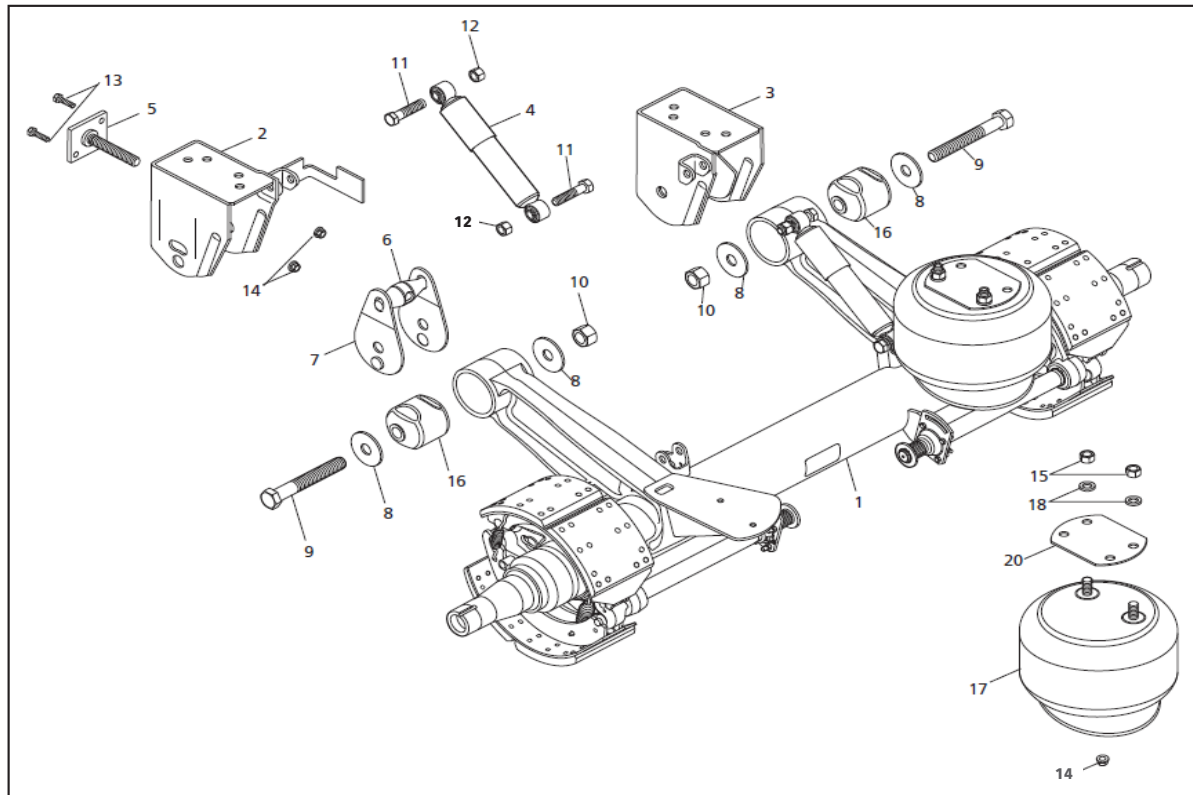

| BOM ID | Qty / Axle | Item No | Description |
|--------|------------|-------------|--|
| 1 | - | N/A | CBX23 W/245 AXLE AND BEAM ASSEMBLY |
| 2 | 1 | 1ASAP4625 | SAF-H FRAME MOUNT, ROAD SIDE, CBX23-245 (90521810) |
| 3 | 1 | 1ASAP4624 | SAF-H FRAME MOUNT, CURB SIDE, CBX23-245 (90521813) |
| 4 | 2 | 1AS90045299 | SAF-H SHOCK ABSORBER, 17" RIDE HEIGHT (90045299) |
| 5 | 1 | 1ASAP4682 | SAF-H THREADED ROD ASSY, CBX SWING-ALIGN (90548007) |
| 6 | 1 | 1ASAP4683 | SAF-H YOKE, CBX SWING-ALIGN (90045491) |
| 7 | 2 | 1ASAP4684 | SAF-H PLATE WELDMENT, CBX SWING-ALIGN (90531339) |
| 8 | 4 | 1ASAP4685 | SAF-H WASHER, 1-1/8" I.D. X 3-1/2" O.D. GR 8 (93600553) |
| 9 | 2 | 1AS48100697 | SAF-H CBX AXLE PIVOT BOLT W/O POSILIFT (48100697) |
| 10 | 2 | 1ASAP4429 | SAF-H NUT, HEX LOCK, 1-1/8" - 7 GR C (93400506) |
| 11 | 4 | 1AFBP3145 | BOLT, HEX HEAD, 3/4" - 10 X 4-1/2", GR 5, PLATED |
| 12 | 4 | 1AFBP3442 | NUT, HEX, 3/4" - 10, TOP LOCK, GR C, PLATED |
| 13 | 2 | 1AFC12HBA05 | BOLT, HEX HEAD, 1/2" - 13 X 2", GR 5, PLATED |
| 14 | 4 | 1AFC08H0000 | NUT, HEX SERRATED FLANGE, 1/2" - 13, PLATED |
| 15 | 4 | 1ASAP4687 | SAF-H AIR SPRING TOP MOUNT NUT, 3/4" - 16, GR B (93400149) |
| 16 | 2 | 1ASAP4688 | SAF-H BUSHING ONLY, PIVOT, CAST BEAM, CBX23-245 (90008247) |
| 16A* | - | N/A | SAF-H BUSHING REPAIR KIT, PIVOT, CAST BEAM, CBX23-245 (48100698) |
| 16B* | - | N/A | SAF-H INSTALL TOOL, PIVOT BUSHING, CAST BEAM, CBX23-245 (50544015) |
| 17 | 2 | 1ASAP4689 | SAF-H AIR SPRING ASSY, 16.0" - 19.0" RIDE HEIGHT (90557399) |
| 18 | 4 | 1AF015L0000 | WASHER, LOCK, 3/4", PLATED |
| 19* | 2 | 1ASAP4779 | STRAP, SHOCK ABSORBER LIMIT, CBX23-245, 17" RIDE HEIGHT |

*NOT SHOWN IN ABOVE PARTS DIAGRAM

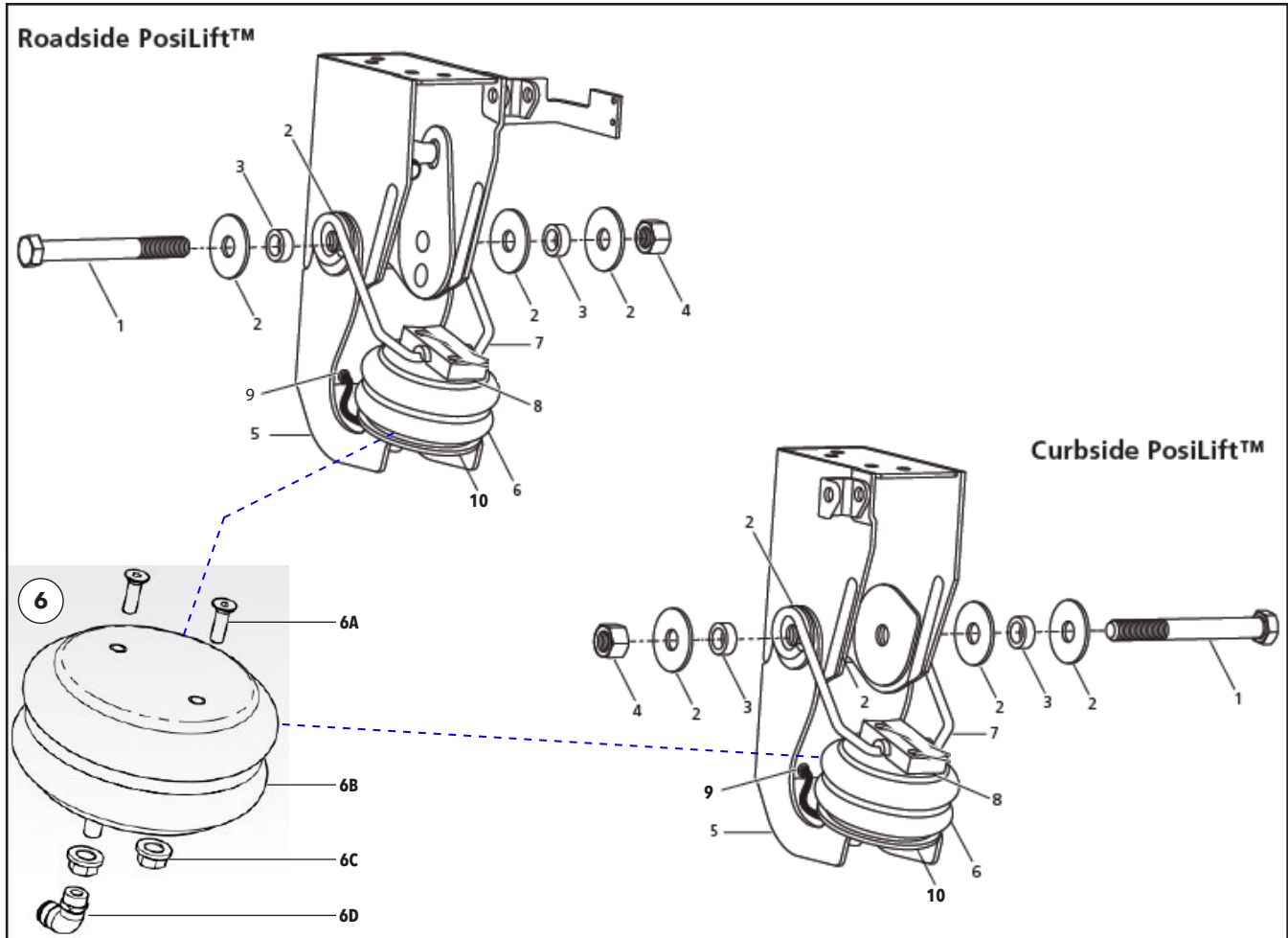

| BOM ID | Qty / Axle | Item No | Description |
|--------|------------|-------------|--|
| 1 | 2 | 1AS11005217 | SAF-H CBX AXLE PIVOT BOLT W/POSILIFT (11005217) |
| 2 | 8 | 1ASAP4685 | SAF-H WASHER, 1-1/8" I.D. X 3-1/2" O.D. GR 8 (93600553) |
| 3 | 4 | N/A | SAF-H SPACER, PIVOT BOLT (93900295) |
| 4 | 2 | 1ASAP4429 | SAF-H NUT, HEX LOCK, 1-1/8" - 7 GR C (93400506) |
| 5 | 2 | N/A | SAF-H CBX POSLIFIT PIVOT MOUNT BRACKET (90026334) |
| 6 | 2 | 1ASNS040000 | SAF-H AIR SPRING KIT, CBX POSILIFT LIFT BAG (48100497) |
| 6A | 4 | N/A | SAF-H CAP SCREW, FLAT-HEAD, HEX BIT (93006039) |
| 6B | 2 | 1ASN0040000 | SAF-H AIR SPRING, CBX POSILIFT LIFT BAG (90557366) |
| 6C | 4 | 1AFC08H0000 | NUT, HEX SERRATED FLANGE, 1/2" - 13, PLATED (93400623) |
| 6D | 2 | 1AB0CL38080 | FITTING, 90* ELBOW, 1/8 MPT X 3/8" TUBE (XB-09226) |
| 7 | 2 | N/A | SAF-H CBX POSILIFT GUIDE ARM (90006624) |
| 8 | 2 | N/A | SAF-H CBX POSILIFT BEARING BLOCK (90045590) |
| 9 | 2 | 1AR00000094 | GROMMET, 3/8" I.D. X 5/8" HOLE (90045591) |
| 10 | 2 | N/A | SAF-H CBX POSILIFT, LIFT AIR SPRING MOUNT PLATE (90034803) |

NOTE: ALL SUSPENSION COMPONENTS ON THE LIFT AXLE ARE IDENTICAL TO THE STANDARD AXLE, EXCEPT FOR THE **POSILIFT™** COMPONENTS LISTED ON THIS PAGE.

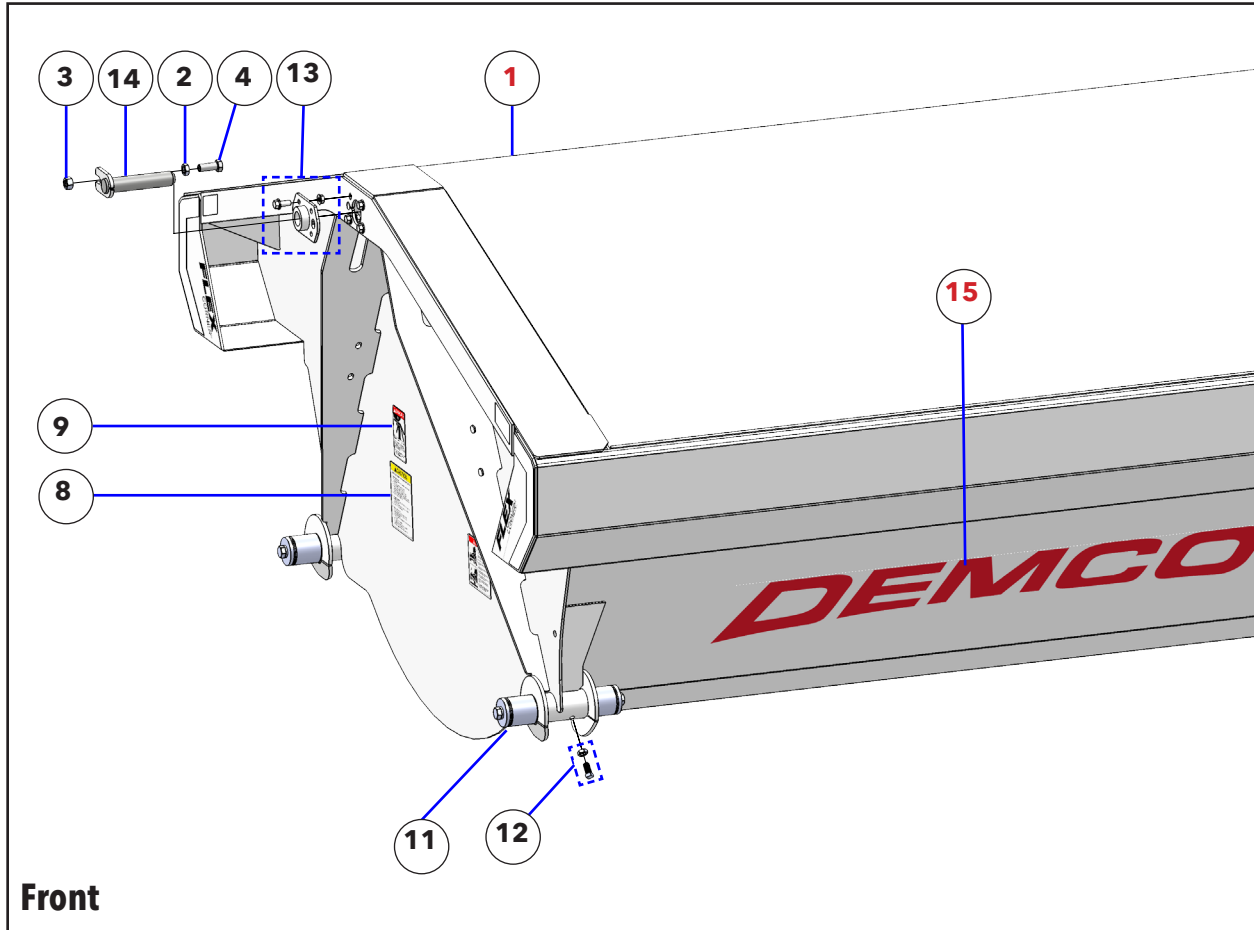

Front

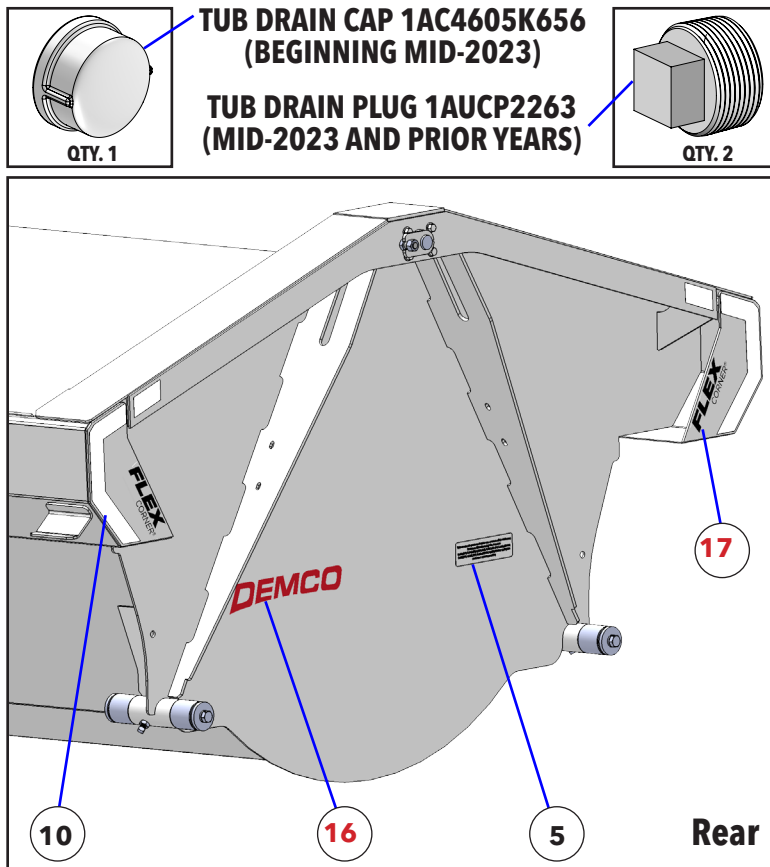

Rear

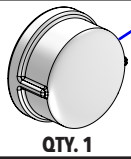

**TUB DRAIN CAP 1AC4605K656
(BEGINNING MID-2023)**

**TUB DRAIN PLUG 1AUCP2263
(MID-2023 AND PRIOR YEARS)**

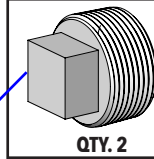

⚠ DANGER

To prevent serious injury or death:

- Before performing maintenance between the frame rails, the trailer should be hooked to tractor on a level surface, fully dumped, then hydraulic hoses disconnected.
- If service requires the tub to be partially dumped refer to operator's manual for proper safety procedures.

AP 2014

1AQAP4361

9

⚠ DANGER

To prevent serious injury or death:

- Close and lock tub latches on pivot side. Open and lock tub latches on opposite side. Operator must remain in cab during dumping operation.
- Stand clear of tub body when operating.
- Stand clear of load during dumping operation.
- Do not attempt to dump load on uneven or unstable ground.
- Do not dump load too slowly. Tub should dump in 20 seconds or less.
- Do not stop cylinder extension in middle of cycle. Equipment may upset.
- Cylinders must be fully retracted while vehicle is unattended or unbraked from trailer.
- Do not perform maintenance on tub body without properly blocking body and cylinder to prevent lowering.

AP 2014

1AQAP3669

7

⚠ CAUTION

Side Dump Checklist and Operating Instructions

- Pre-Use Heating
 - Connect air lines and set trailer brakes after backing.
 - Check tires.
 - Check engine fluids on the ground.
 - Connect light cord and check all lights.
 - Close and lock hoods on one side of trailer.
 - Open and lock hoods on other side of trailer.
 - Connect hydraulic lines and fill subject way several times to fill hydraulic cylinder. Retract hydraulic fluid.
 - Check wheel lubrication level.
- 100 Mile Check List
 - Tighten all axle bolts (300 to 350 ft. lbs. torque) and suspension bolts.
 - Check mounting bolts on landing gear or stands.
 - Check wheel bolts for tightness.
- Ongoing Maintenance
 - Wear proper dress and method.
 - Check wheel lubrication for proper oil level.
 - Check hydraulic cylinder pinents, tub pins and brake assemblies.
 - Load with items as safe.
 - Load should be evenly distributed on trailer.
 - DO NOT OPERATE TRAILER.
 - Check suspension bolts at 90 day intervals.

AP 2014

1AQAP3670

8

⚠ WARNING

HIGH-PRESSURE FLUID HAZARD

To prevent serious injury or death:

- Relieve pressure on system before repairing or adjusting or disconnecting.
- Wear proper hand and eye protection when searching for leaks. Use wood or cardboard instead of hands.
- Keep all components in good repair.

AP 2014

1AQAP2914

6

This product is protected under one or more of the following Demco Patents:
 5,480,214; 5,845,971; 6,257,670 B1; 6,402,453 B1;
 6,425,726; 6,428,264; 6,488,340 B2; 6,520,589 B2; 6,554,364
 and other patents pending

5

1AQAP2491

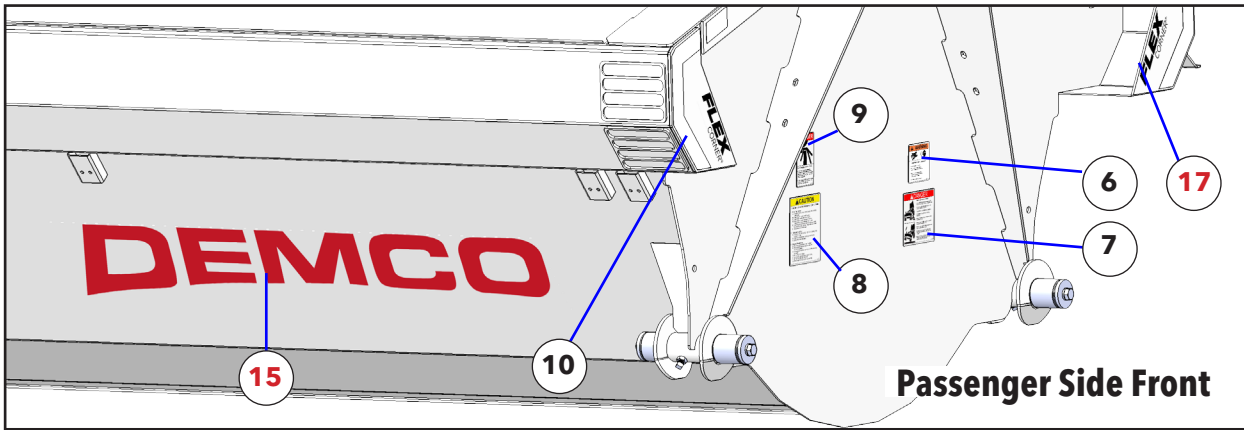

NOTE: A RED BOM ID# indicates an option.

| BOM ID | Qty | Item No | Description |
|--------|-----|-------------|---|
| 1 | 1 | 5C000283 | MY24 34' TUB, 1/4" AR450 |
| 1 | 1 | 5C000203 | MY24 34' TUB, 3/16" AR450 |
| 2 | 2 | 1AFBP3107 | NUT, HEX JAM, 3/4"-10, GR 2, PLTD |
| 3 | 2 | 1AFC05L0005 | NUT, HEX LOCK, 3/4"-10, GR 2, PLTD |
| 4 | 2 | 1AFC12LBAH8 | HEX BOLT, 3/4-10 x 2-1/2, GR 8, YELLOW ZINC |
| 5 | 1 | 1AQAP2491 | DECAL, PATENT PROTECTION, 8-1/2"W X 2-1/2"L |
| 6 | 1 | 1AQAP2914 | DECAL, WARNING (HIGH-PRESSURE FLUID) 4"W X 4"L |
| 7 | 1 | 1AQAP3669 | DECAL, DANGER (LOAD DUMPING SAFETY) 8"W X 5-1/2"L |
| 8 | 1 | 1AQAP3670 | DECAL, CAUTION (SIDE DUMP CHECKLIST & INST) 6"W X 7"L |
| 9 | 1 | 1AQAP4361 | DECAL, DANGER (FRAME AREA MAINT) 3"W X 6-1/4"L |
| 10 | 4 | 1AQAT000000 | WHITE CONSPICUITY TAPE, 2" WIDE |
| 11 | 4 | 4CFK2005 | PIVOT PIN & BUSHING KIT (See sub-assembly parts list below) |
| 12 | 4 | 4CAAM7991 | ASSEMBLY, SET SCREW & JAM NUT, 5/8"-11 X 1-1/4", PLTD |
| 12A | 4 | 1AFBP3080 | NUT, HEX JAM, 5/8"-11, GR 2, PLTD |
| 12B | 4 | 1AFBP3673 | SET SCREW, SQ HEAD, 5/8"-11 X 1-1/4", PLTD |
| 13 | 2 | 5C000015 | ADJUSTABLE TOP CYLINDER MOUNT ASSEMBLY |
| 13A | 4 | 1AFC08H0000 | NUT, HEX SERRATED FLANGE, 1/2"-13, PLTD |
| 13B | 4 | 1AFC37HAAD5 | HEX CAP SCREW, 1/2"-13 X 1-1/4", SERRATED FLANGE HD, PLTD |
| 14 | 2 | 5CAM9057 | PIN, CYLINDER, 1-1/2" X 7-1/8", ANTI-ROTATION, PLTD |
| 15 | 2 | DE21026 | DECAL, DEMCO LOGO, X-LARGE RED |
| 15 | 2 | DE21027 | DECAL, DEMCO LOGO, X-LARGE WHITE |
| 16 | 1 | DE21004 | DECAL, DEMCO LOGO, SMALL WHITE |
| 16 | 1 | DE21005 | DECAL, DEMCO LOGO, SMALL RED |
| 17 | 4 | DE21024 | DECAL, FLEX CORNER, BLACK |
| 17 | 4 | DE21025 | DECAL, FLEX CORNER, WHITE, |

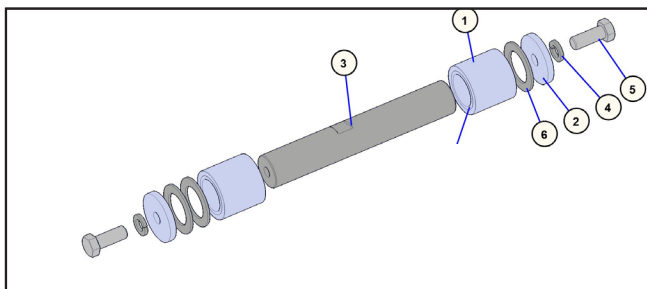

| 4CFK2005 PIVOT PIN & BUSHING KIT | | | |
|----------------------------------|-----|-------------|--|
| BOM ID | Qty | Item No | Description |
| 1 | 2 | 4CAAM7990 | ASSEMBLY, TUB PIVOT BEARING |
| 2 | 2 | 3CAM9026 | WASHER, PIVOT PIN |
| 3 | 1 | 1AUAM9136 | PIVOT PIN, 2" X 12-1/8" OAL, PLTD |
| 4 | 2 | 1AF015L0000 | WASHER, LOCK, 3/4", PLTD |
| 5 | 2 | 1AFBP3139 | HEX CAP SCREW, 3/4"-10 X 2", GR 5, PLTD |
| 6 | 3 | 1AFBP3599 | MACHINERY BUSHING, 3" OD X 2" ID X 10 GA, PLTD |

OPTIONAL PARTS SECTION

The following pages contain parts information for accessories that can be added to your Demco Side Dump Trailer.

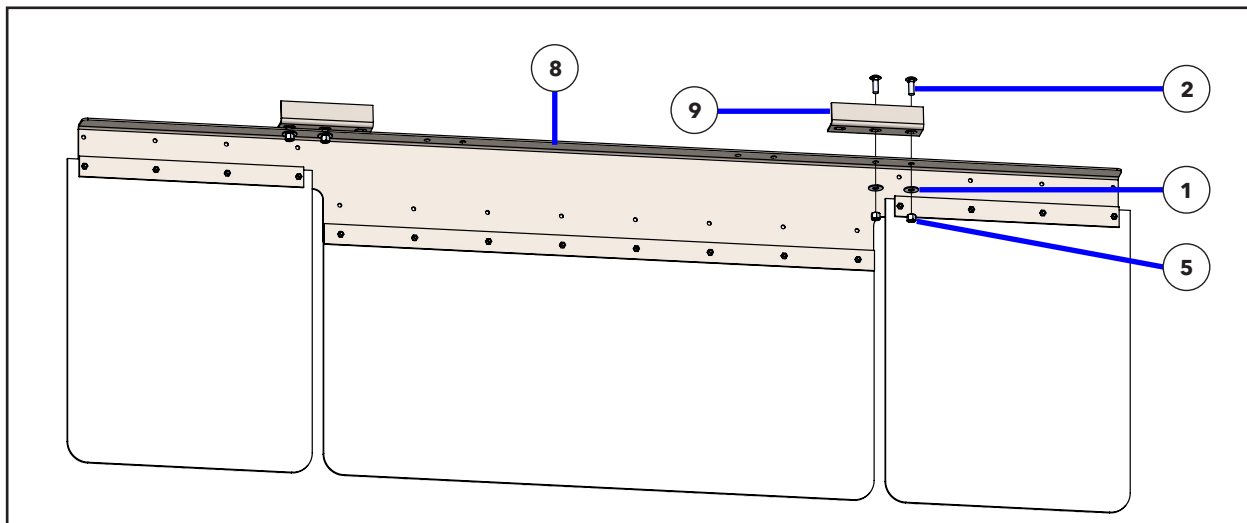
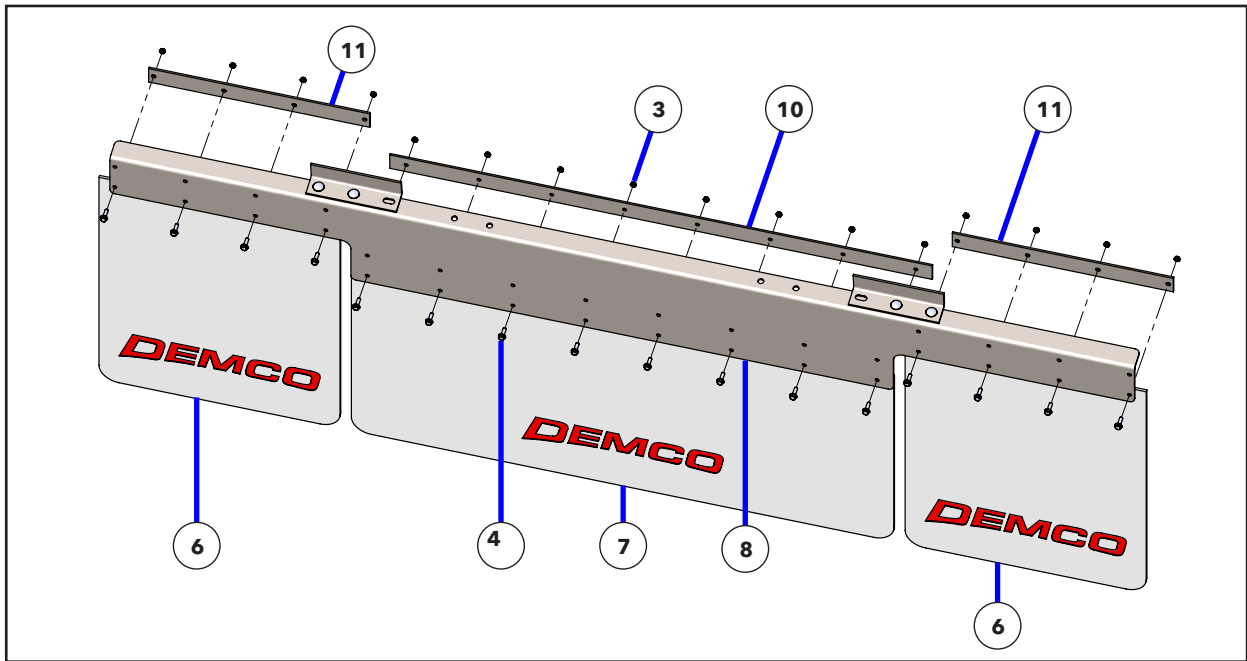

5C000184 (FRONT CENTER MUDFLAP OPTION)

| BOM ID | Qty | Item No | Description |
|--------|-----|-------------|--|
| 1 | 4 | 1AF009H0000 | WASHER, FLAT, 1/2", PLTD |
| 2 | 4 | 1AFBP3232 | BOLT, CARRIAGE, 1/2"-13 X 1-1/2", GR 5 |
| 3 | 16 | 1AFBP3644 | NUT, HEX LOCK, 5/16"-18 TOP LOCK, PLTD |
| 4 | 16 | 1AFBP3709 | BOLT, FLANGE HEAD, 5/16"-18 X 1", GR 8, PLTD |
| 5 | 4 | 1AFC18H0000 | NUT, HEX LOCK, 1/2"-13, NYLOCK, PLTD |
| 6 | 2 | 1AU00000804 | MUDFLAP, DEMCO, 24" X 30" |
| 7 | 1 | 1AU00000807 | CENTER MUDFLAP, 54" X 24.5" W/ LOGO |
| 8 | 1 | 3C000178 | FRONT CENTER MUDFLAP BRKT |
| 9 | 2 | 3C000179 | FRONT CENTER MUDFLAP CLAMP |
| 10 | 1 | 3C000180 | CENTER MUDFLAP BACKING STRAP |
| 11 | 2 | 3CAM9035 | MUDFLAP BACKING STRAP |

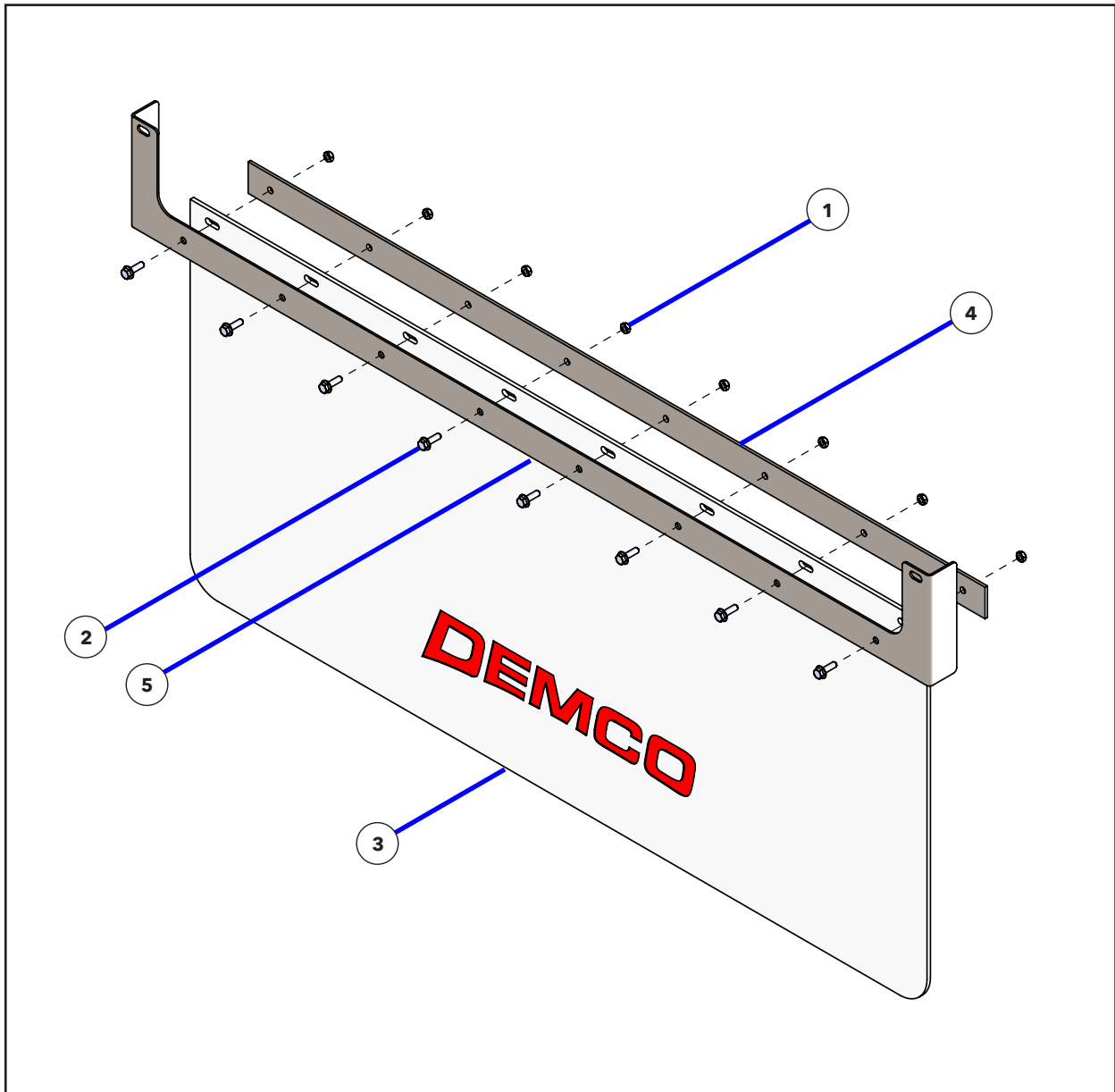

| 5C000186 (REAR CENTER MUDFLAP OPTION) | | | |
|--|------------|----------------|---|
| BOM ID | Qty | Item No | Description |
| 1 | 8 | 1AFBP3644 | NUT, HEX LOCK, 5/16"-18 TOP LOCK, PLTD |
| 2 | 8 | 1AFBP3709 | BOLT, FLANGE HEAD, 5/16"-18 X 1, GR 8, PLTD |
| 3 | 1 | 1AU00000807 | CENTER MUDFLAP, 54" X 24.5" W/ LOGO |
| 4 | 1 | 3C000180 | CENTER MUDFLAP BACKING STRAP |
| 5 | 1 | 5C000185 | REAR CENTER MUDFLAP BRKT WELDMENT |

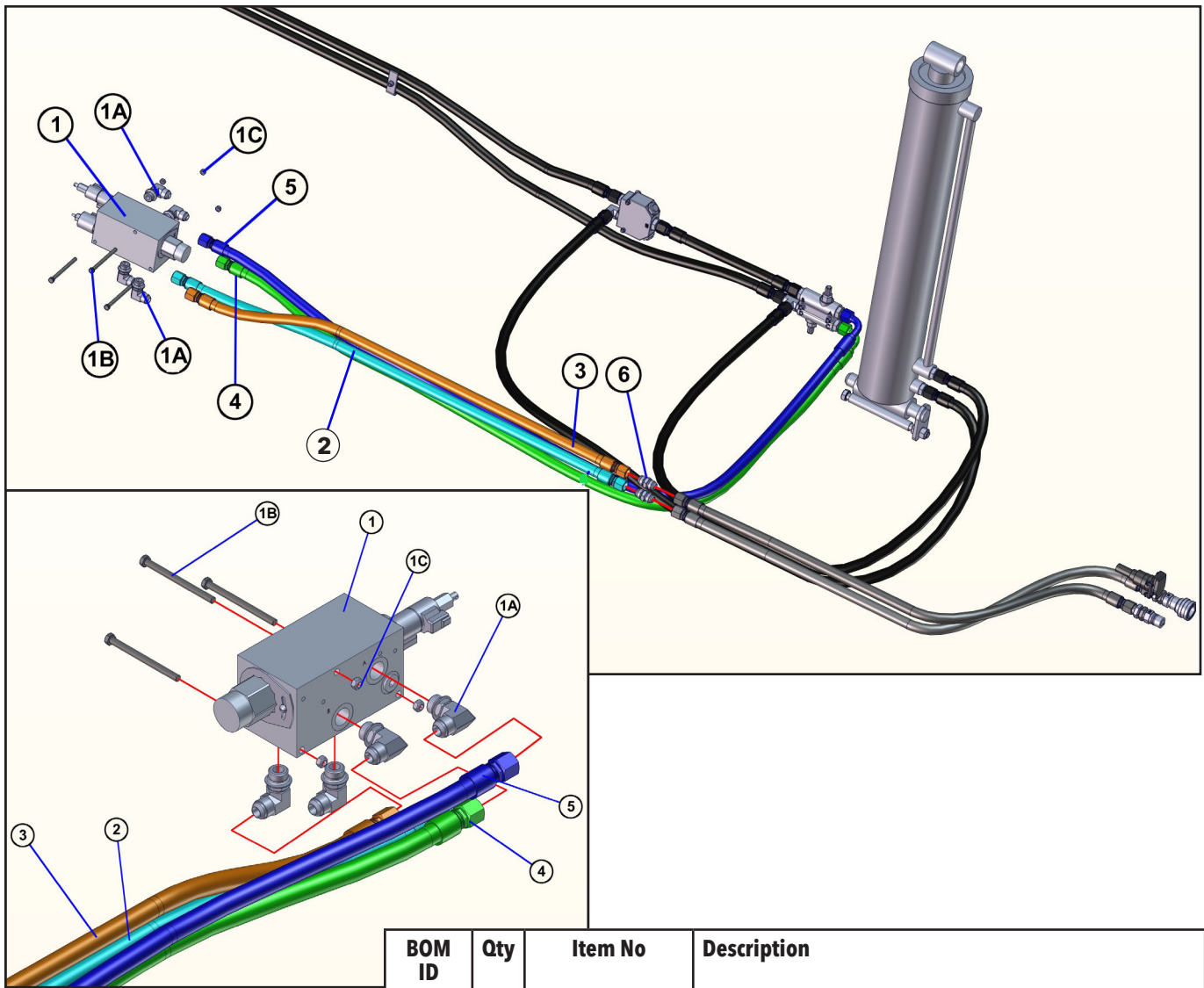

| BOM ID | Qty | Item No | Description |
|--------|-----|-----------|--|
| 1 | 1 | 1AAAP4543 | VALVE, EOH, TRAILERPRO 302-578 |
| 1A | 4 | 1AKDP6538 | ADAPTER, 12MJ-12MSAE 90 DEGREE, 6801-12 |
| 1B | 3 | 1AFBP3118 | HEX CAP SCREW, 3/8"-16 X 5", GR 5, PLTD |
| 1C | 3 | 1AFBP3612 | NUT, HEX LOCK, 3/8"-16, TOP LOCK, GR C, PLTD |
| 2 | 1 | 1AKDP6546 | HOSE, HYDRAULIC, 3/4" X 57", 12FJX-12FJX |
| 3 | 1 | 1AKDP6554 | HOSE, HYDRAULIC, 3/4" X 53", 12FJX-12FJX |
| 4 | 1 | 1AKDP6614 | HOSE, HYDRAULIC, 3/4" X 105", 12FJX-12FJX90 |
| 5 | 1 | 1AKDP6615 | HOSE, HYDRAULIC, 3/4" X 108", 12FJX-12FJX90 |
| 6 | 2 | 1AKDP4388 | UNION, 12MJ-12MJ, 2403-12 |

TO CONVERT YOUR SIDE DUMP TO TRAILER PRO ELECTRIC CONTROLS, CONTACT YOUR DEALER FOR COMPLETE KIT AND PRICING FOR **4CFK2018 (KIT, TRAILER PRO, EOH VALVE ADD-ON)**.

TO ADD A CONTROL BOX TO A SECOND TRACTOR:
CONTACT YOUR DEALER FOR
4CFK2017 (KIT, TRAILER PRO CONTROL BOX FOR 2ND TRACTOR, W/ROLL-RITE)
FOR DEMCO SIDE DUMPS EQUIPPED WITH ROLL-RITE TARPS;

-OR-

CONTACT YOUR DEALER FOR
4CFK2016 (KIT, TRAILER PRO CONTROL BOX FOR 2ND TRACTOR, W/AERO)
FOR DEMCO SIDE DUMPS EQUIPPED WITH AERO TARPS.

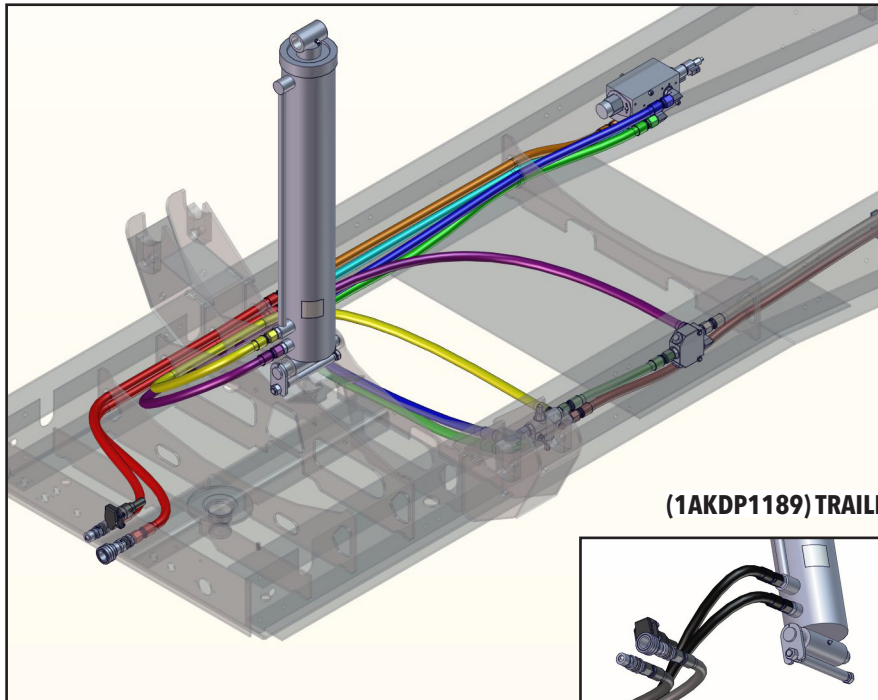

(1AKDP1189) TRAILER PRO HOSE KIT; 4CFK2018

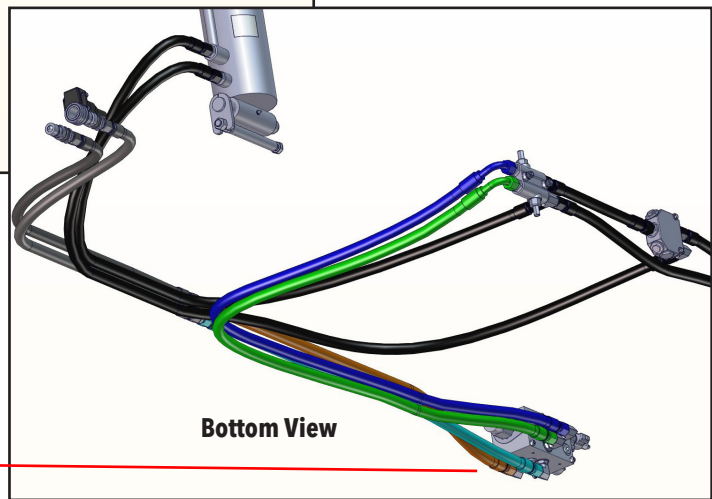

Bottom View

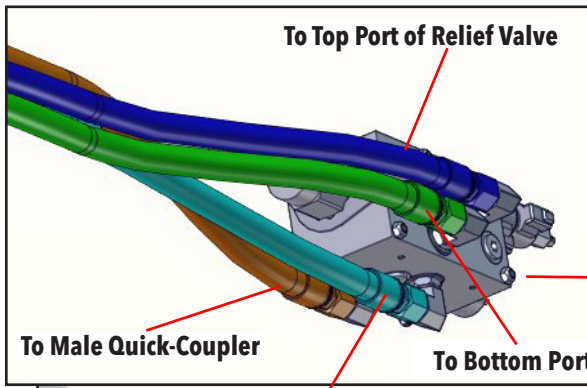

To Top Port of Relief Valve

To Male Quick-Coupler

To Bottom Port of Relief Valve

To Female Quick-Coupler

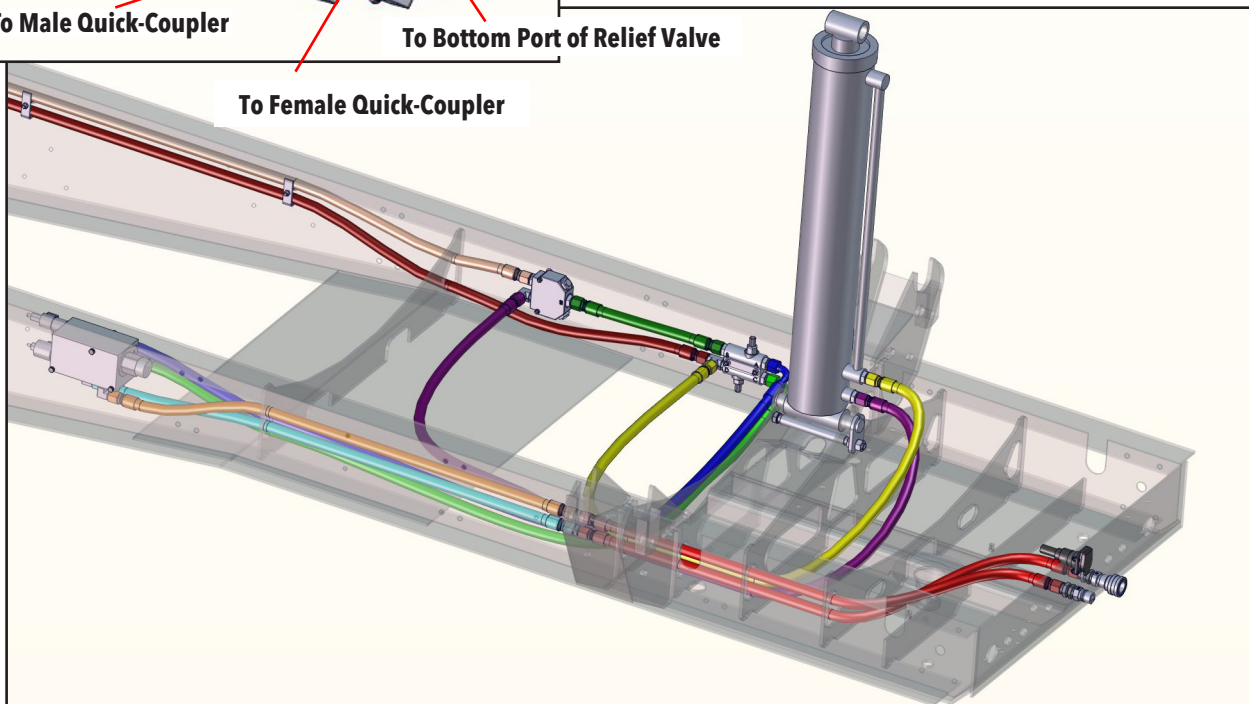

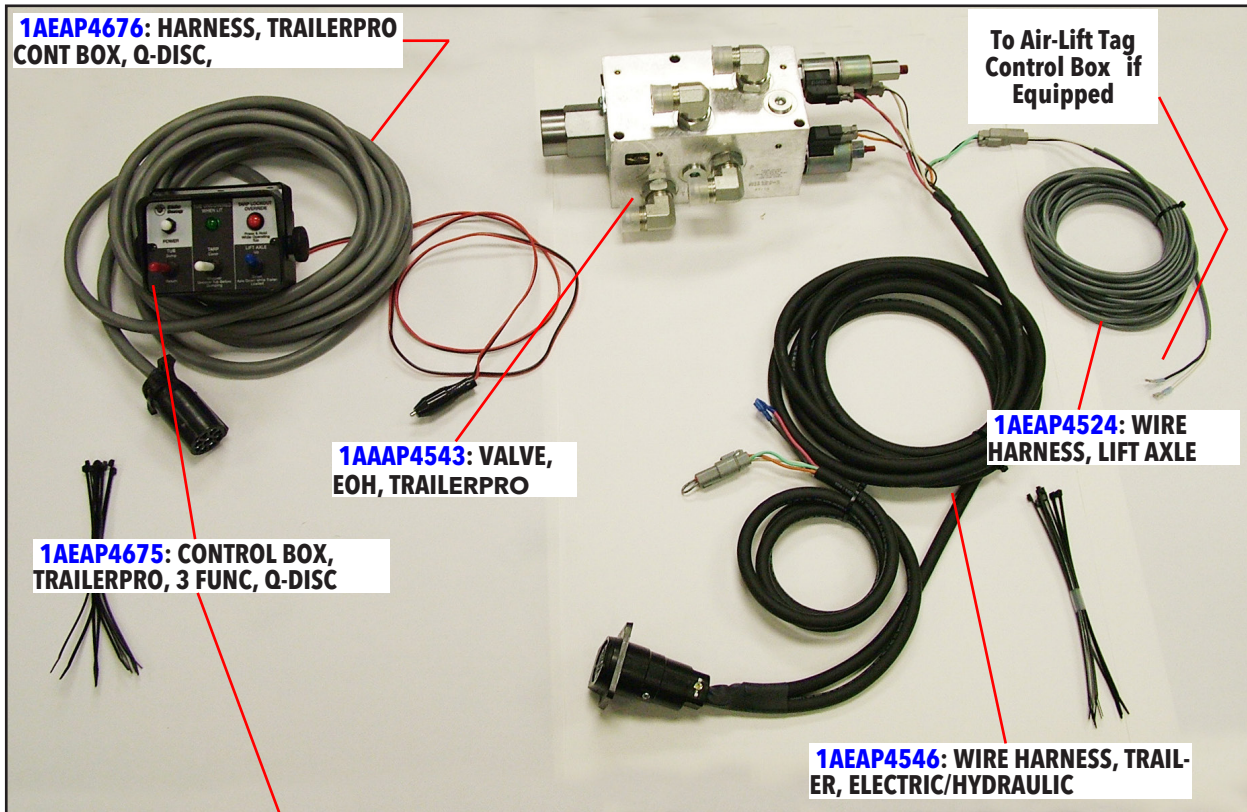

ELECTRIC OVER HYDRAULIC CONTROL OPTION

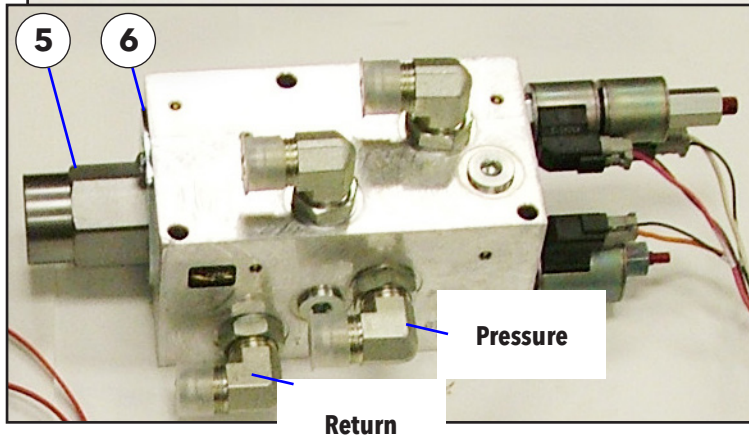
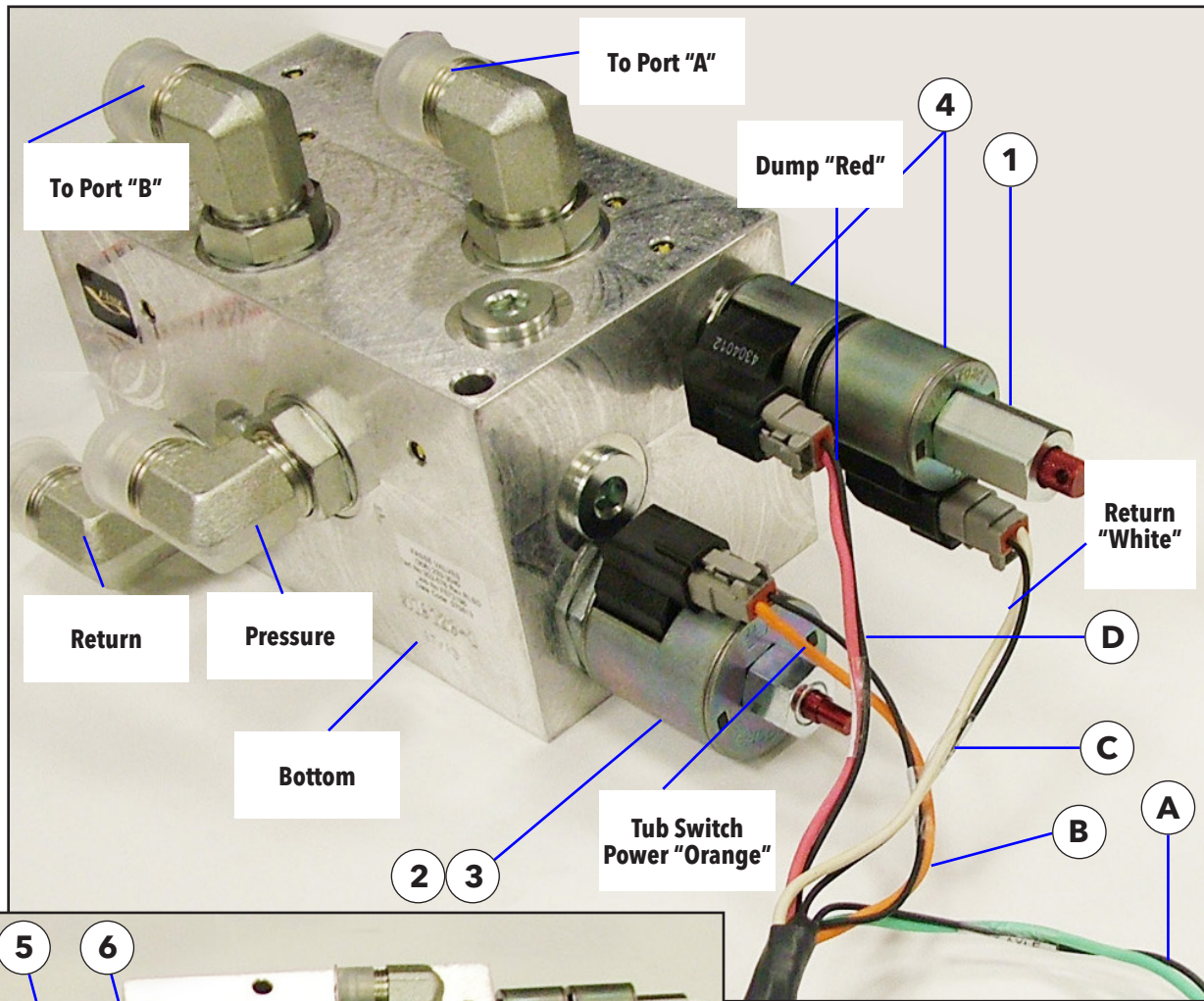

| BOM ID | Color | Connection |
|--------|----------------|---------------------------------|
| A | GREEN / BLACK | TO LIFT AXLE |
| B | ORANGE / BLACK | FLOW CONTROL COIL |
| C | WHITE / BLACK | DIRECTIONAL CONTROL COIL RETURN |
| D | RED / BLACK | DIRECTIONAL CONTROL COIL DUMP |

| BOM ID | Qty | Item No | Description |
|--------|-----|-------------|---|
| 1 | 1 | 1AAAP4590 | CARTRIDGE, EOH VALVE, DIRECTIONAL, 273-982 |
| 2 | 1 | 1AAAP4591 | CARTRIDGE, EOH VALVE, FLOW CONTROL, 273-339 |
| 3 | 1 | 1AAAP4605 | COIL, EOH VALVE, 1.81" OD, FLOW CONTROL, 10V, 253-800 |
| 4 | 2 | 1AAAP4606 | COIL, EOH VALVE, 1.43" OD, DIRECTIONAL, 10V, 253-071 |
| 5 | 1 | 1AK00273340 | CARTRIDGE, HYD, HPD42-S67C, 273-340 |
| 6 | 1 | 1AK00273341 | LOCK NUT ADAPTER, CARTRIDGE HYD, 273-341 |

Installing the Control Box in the Tractor

Find a suitable location in the cab of the tractor and mount the control box. The red and black two wire cable attached to the back of the box is the power cable. Plug the cigarette lighter end into a power outlet in the cab.

If you do not have an available outlet for the cigarette lighter end, use the following instructions:

- Cut the cigarette lighter plug off.
- Split apart the wires and connect the red wire to a 12 volt dc power source and the black wire to ground.
- A bag of terminals is included to allow you to tap into most fuse panels.



WARNING: Red wire must be positive and black wire negative. Reversing these wires can damage the control system. Route the gray cord and male 9 pole plug out of the cab and to the front bulkhead of the side dump. Plug the cord into the female 9 pole socket on the side dump bulkhead.

To operate your Demco side dump, your tractor will need a hydraulic pump that can supply a minimum of 25gpm to the trailer at 2,500 psi. See page 36 for more information on the tractor's hydraulic requirements.

Operating the TrailerPro Control Box

If your side dump is equipped with a tarp, you will also need to wire a power cord from the tractor's battery to the side dump to supply power to the tarp's motor. For wiring instructions, see pages 56-58 for an Aero tarp option or pages 64-66 for a Roll-Rite tarp option. For more detailed wiring instructions, refer to the online Parts Manual.

Press the "Power" button to turn the system on. The button will light up to indicate the power is on. Press the button again to turn the system off.

Dumping the Tub

When the green light in the top center is illuminated, the tub can be dumped. (See Tarp Lock Out Option on next page.)

The red switch in the lower left corner operates the tub. To dump the tub, turn on the tractor's hydraulic pump and then lift and hold the red toggle in the "dump" position to raise the tub and empty its contents. Release the switch when the cylinders reach the fully extended position.



WARNING: Do not stop dumping the load in mid dump and then try to return the tub to the transport position. You may tip over the side dump instead of returning the tub. Push and hold the red switch in the "Return" position to bring the tub back to its transport position. Release the switch when the cylinders are fully retracted.

ELECTRIC OVER HYDRAULIC CONTROL OPTION

Operating the Tarp (If Equipped)



The white switch in the lower middle operates the tarp. Lift and hold the white switch to unroll the tarp and cover the tub. Push down and hold the switch to roll the tarp and uncover the tub.

WARNING: When rolling the tarp do not continue to hold the switch after the tarp has reached its fully rolled position. Damage to the tarp or the motor can occur when the motor continues to try to roll the tarp after it has reached its fully rolled position.

Operating the Lift Axle (If Equipped)



The blue switch in the lower right corner controls the lift axle option. Lifting the switch to the up position raises the lift axle and pushing the switch down lowers the lift axle. There is a manual control switch for the lift axle in the gray plastic box at the back of the side dump. There is also a regulator in the box that adjusts the amount of weight the lift axle carries. Instructions are printed inside the box.

WARNING: Always lower the lift axle when the side dump is loaded. Damage to the side dump's frame can occur if the side dump is transported loaded with the lift axle in the raised position.

Using the Tarp Lock Out Option

The Tarp Lock Out prevents the tub from being dumped while the tarp is covering the tub. Dumping the contents of the tub while the tarp covers the tub will ruin the tarp and may cause the side dump to tip over.

If your side dump has a tarp and you purchased the tarp lockout option, the green light and the red button in the top row of the control box will be used. The green light will illuminate when the tarp is in the fully rolled up position.

Once the green light is on, the red switch will be able to operate the tub. If the green light is not illuminated the red switch is "locked out" and the tub can't be moved.

The red button will allow you to dump the tub regardless of the position of the tarp. If the sensor for the green light is damaged or fails, or if you want to tip the tub with the tarp unrolled for maintenance, you can push and hold the red button while using the red switch to move the tub.

CAUTION: If the Tarp Lock Out option is not installed on your side dump, the green light will be illuminated all the time, regardless of the tarp's position.

The Tarp Lock Out can be added to any side dump with a TrailerPro control box. Contact your Demco Dealer for more information. Specify the brand of tarp you have when placing your order.

The following Demco mounting parts are needed if an Aero Electric Tarp option is added.

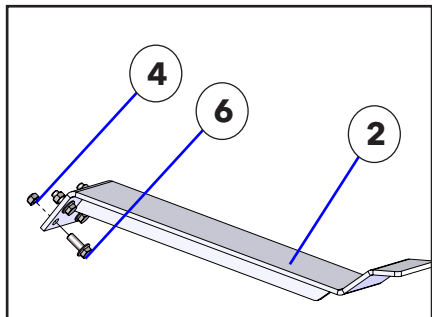
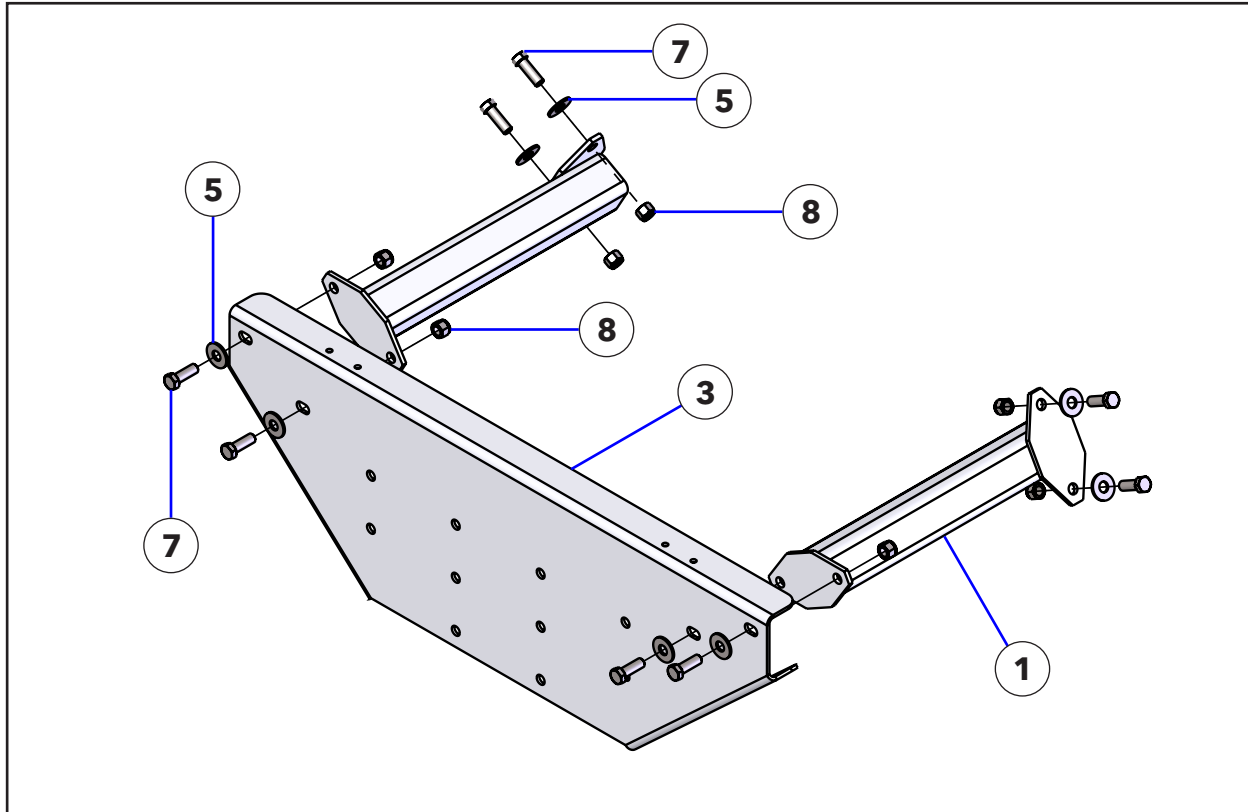

| BOM ID | Qty | Item No | Description |
|--------|-----|-------------|---|
| 1 | 4 | 5CAM9038 | TARP CHANNEL MOUNT |
| 2 | 2 | 5C000008 | TARP SUPPORT BRACKET, AERO/ROLL-RITE |
| 3 | 2 | 5C000021 | AERO TARP MOUNT PLATE ASSY |
| 4 | 8 | 1AFBP3612 | NUT, HEX LOCK, 3/8-16, TOP LOCK, GR C, PLTD |
| 5 | 16 | 1AF009H0000 | WASHER, FLAT, 1/2", PLTD |
| 6 | 8 | 1AFC12FAA05 | HEX BOLT, 3/8-16 X 1", GR 5, PLTD |
| 7 | 16 | 1AFC12HAAH8 | HEX BOLT, 1/2-13 X 1-1/2", GR 8, PLTD |
| 8 | 16 | 1AFC18H0000 | NUT, HEX LOCK, 1/2-13, NYLOK, PLTD |

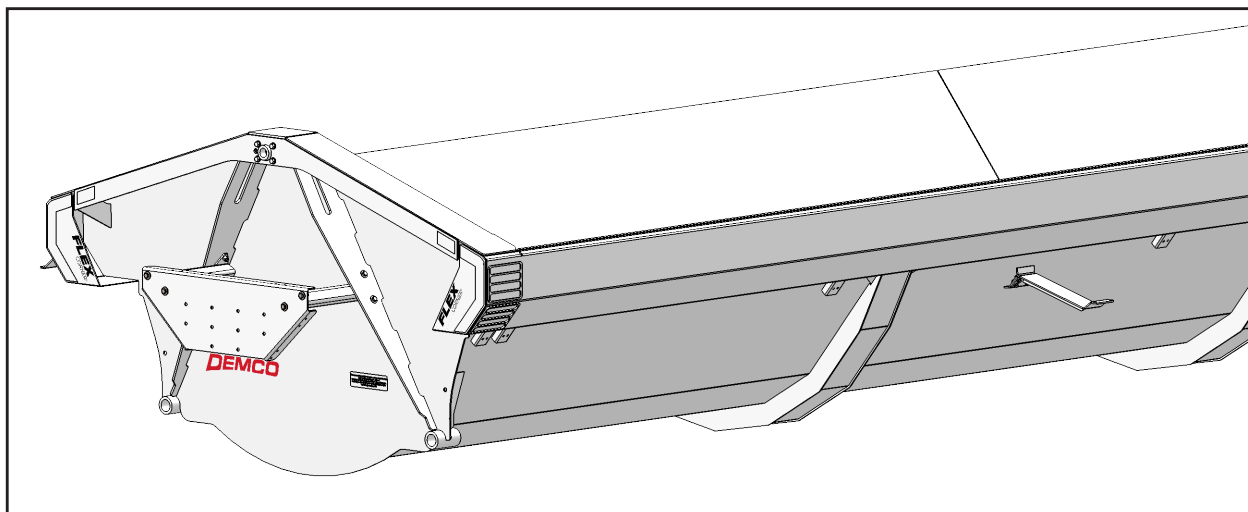

ELECTRIC TARP OPTION -- AERO

The following pages contain Parts Lists for the Aero Electric Tarp option. For additional questions regarding these parts, contact Aero directly at 1-800-535-9545 or online at www.aeroindustries.com.

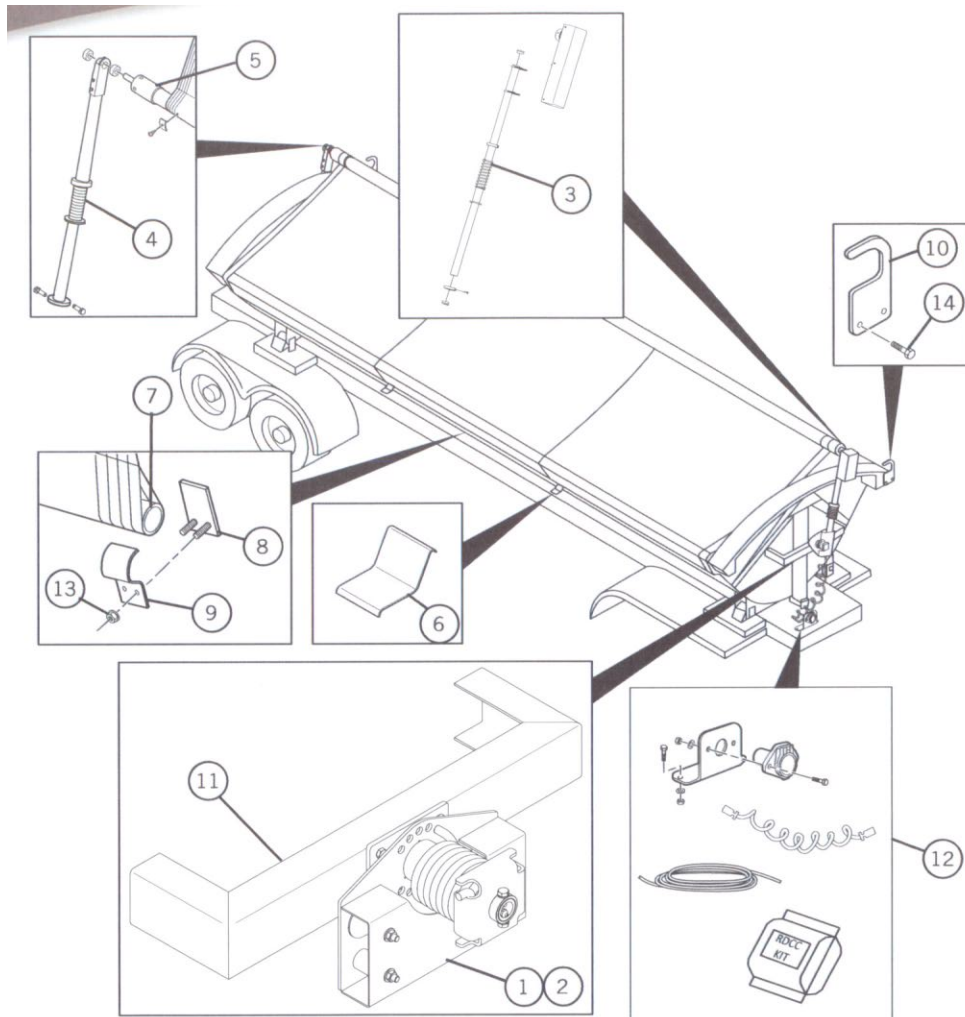

| No. | Part No. | Description | Qty | Page |
|-----|-------------|------------------------------|-----|-------|
| 1 | 1001-961700 | Spring Mount Assembly Front | 1 | 19-20 |
| 2 | 1001-961701 | Spring Mount Assembly Rear | 1 | 19-20 |
| 3 | 1001-961703 | Front Swing Arm Assembly | 1 | 21-22 |
| 4 | 1001-961705 | Rear Swing Arm Assembly | 1 | 23 |
| 5 | 1001-961702 | Roll Tube Assemble | 1 | |
| 6 | 1001-860166 | Tarp Cradle | 2 | |
| 7 | 1440-281223 | Fixed Tube | 2 | |
| 8 | 1001-961304 | Quick Release Clamp Weldment | 7 | |
| 9 | 1040-960158 | Quick Release Clamp | 7 | |
| 10 | 1001-861320 | Tarp Stop Hook | 2 | |
| 11 | | Swing Arm Mounting Hardware | | 18 |
| 12 | | Electrical Hardware | | 24 |
| 13 | 0815-660210 | 5/16-18 Flange Nut | 14 | |
| 14 | 0810-650510 | 5/16 Self-Tapping Screw | 4 | |

*Roll Tube Assemble includes the Fixed Tube

Spring Mount Assemblies

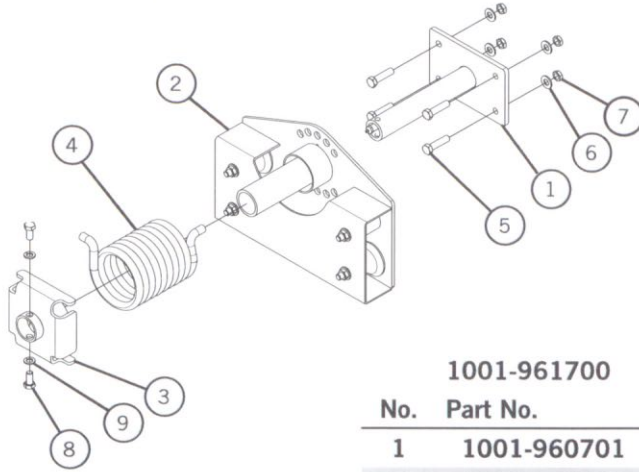

| No. | Part No. | Description | Qty |
|-----|-------------|---------------------------|-----|
| 1 | 1001-960701 | Spring Mount Post | 1 |
| 2 | 1001-961410 | Roller Plate Assembly | 1 |
| 3 | 1001-960703 | Spring Stop Assy | 1 |
| 4 | 1001-861408 | SK2 Hub Spring LH | 1 |
| 5 | 0810-600002 | 1/2-13 x 2 Hex Bolt | 4 |
| 6 | 0820-680810 | 1/2 Flat Washer | 4 |
| 7 | 0815-660127 | 1/2-13 NYLOCK Hex Jam Nut | 4 |
| 8 | 0810-650553 | 1/2-13 x 3/4 SHCS | 2 |
| 9 | 0820-680820 | 1/2 Lock Washer | 2 |

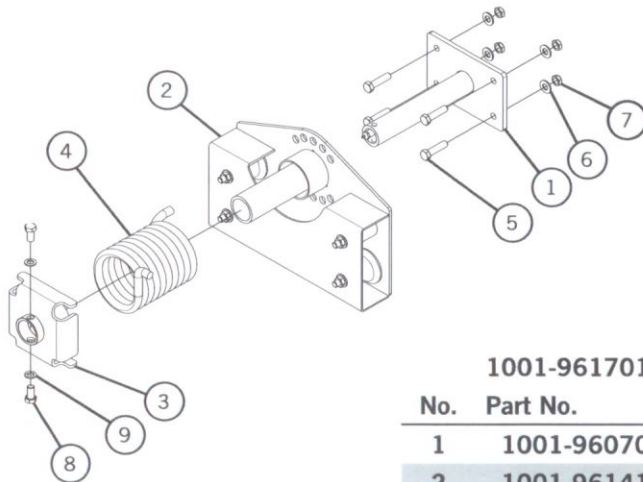

| No. | Part No. | Description | Qty |
|-----|-------------|---------------------------|-----|
| 1 | 1001-960701 | Spring Mount Post | 1 |
| 2 | 1001-961410 | Roller Plate Assembly | 1 |
| 3 | 1001-960703 | Spring Stop Assy | 1 |
| 4 | 1001-861400 | SK2 Hub Spring RH | 1 |
| 5 | 0810-600002 | 1/2-13 x 2 Hex Bolt | 4 |
| 6 | 0820-680810 | 1/2 Flat Washer | 4 |
| 7 | 0815-660127 | 1/2-13 NYLOCK Hex Jam Nut | 4 |
| 8 | 0810-650553 | 1/2-13 x 3/4 SHCS | 2 |
| 9 | 0820-680820 | 1/2 Lock Washer | 2 |

Roller Plate Assembly

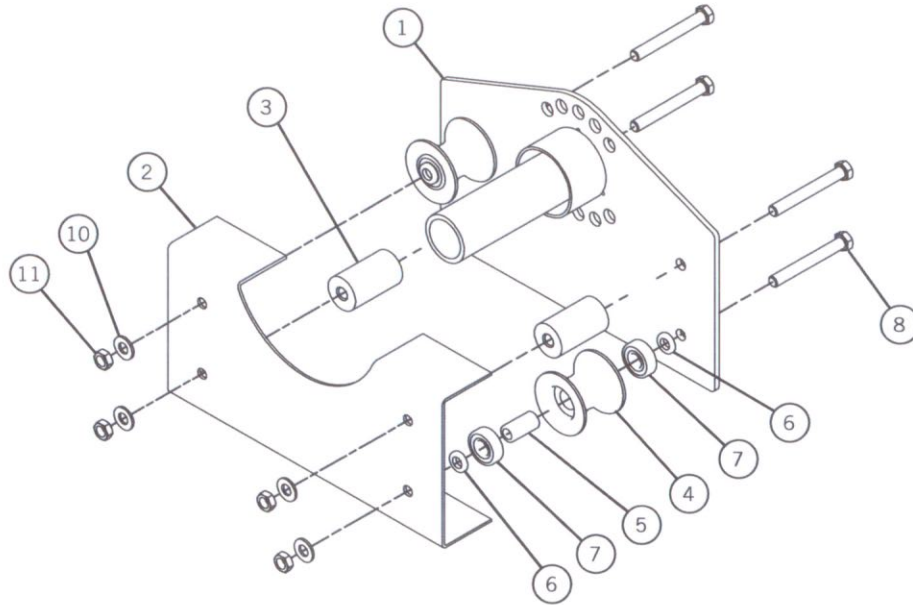

| No. | Part No. | Description | Qty |
|-----|-------------|----------------------------|-----|
| | 1001-961410 | Roller Plate Assembly | |
| 1 | 1001-960702 | Swivel Collar Assembly | 1 |
| 2 | 1001-861411 | Roller Plate | 1 |
| 3 | 1001-861412 | Roller Block | 2 |
| 4 | 1001-861325 | Roller Radius | 2 |
| 5 | 1001-861304 | Roller Spacer "V" | 2 |
| 6 | 1001-861307 | Steel Washer | 4 |
| 7 | 0710-602144 | Bearing .5" ID x 1.575" OD | 4 |
| 8 | 0810-650839 | 1/2-13 x 4 Hex Bolt | 4 |
| 9 | 0815-660127 | 1/2-13 NYLOCK Hex Nut | 4 |
| 10 | 0820-680810 | 1/2 Flat Washer | 4 |

Front Swing Arm

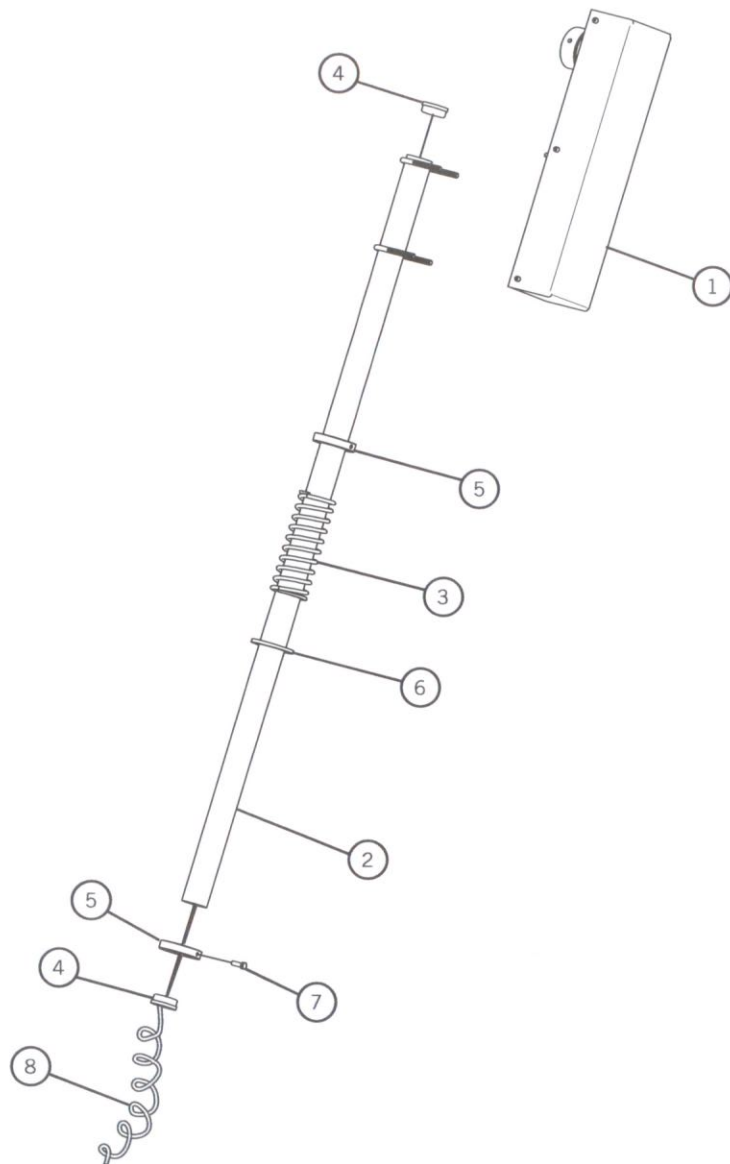

| No. | Part No. | Description | Qty |
|-----|-------------|---|-----|
| | 1001-961703 | Front Swing Arm | |
| 1 | | Motor Drive Unit Assembly (See Page 22) | |
| 2 | 1440-281635 | Steel Tube 2" Rd x 5' Lg | 1 |
| 3 | 0715-619405 | Compression Spring Jumbo | 1 |
| 4 | 1001-861309 | Swing Arm Tube Plug | 2 |
| 5 | 1001-861316 | Collar Lock Swing Arm | 2 |
| 6 | 0820-680401 | Washer 1/4 x 2 1/4 x 3 1/4 | 1 |
| 7 | 0810-650170 | 5/16-18 x 1 Hex Bolt W/Patch | 2 |
| 8 | 0755-626433 | Flex Cord Motor to Plug | 1 |

Motor Drive Assembly

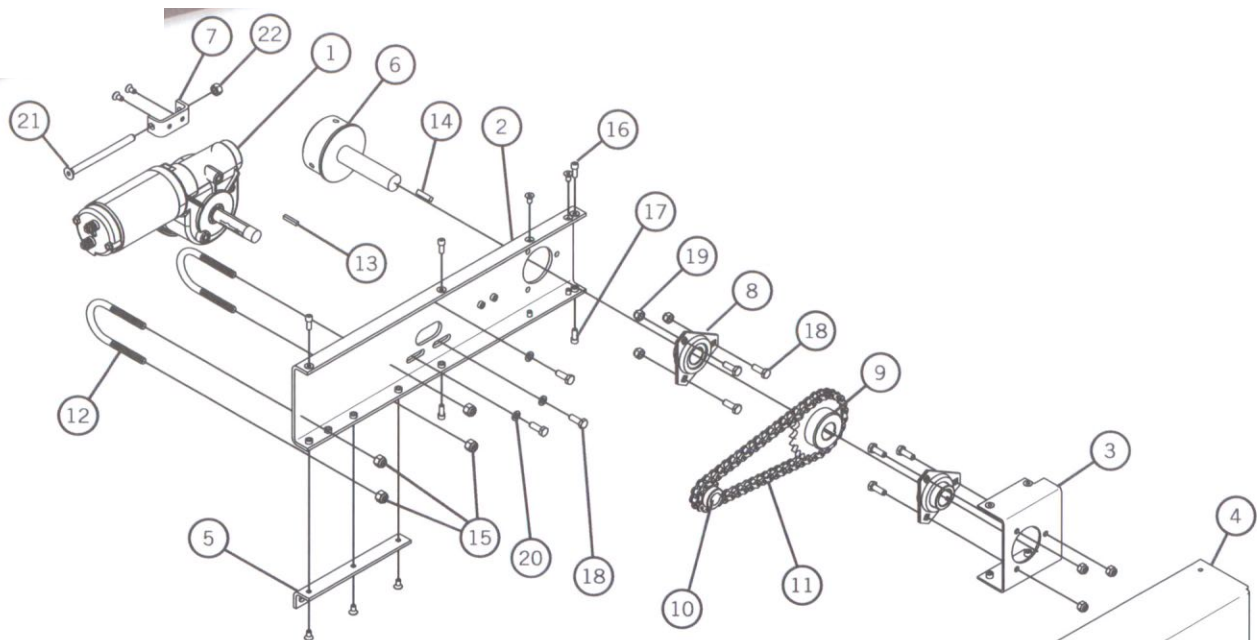

| Motor Drive Assembly | | | |
|----------------------|-------------|-----------------------------|-----|
| No. | Part No. | Description | Qty |
| 1 | 0755-623421 | Motor RA/SWB | 1 |
| 2 | 1001-960710 | Drive Mount Channel Assy | 1 |
| 3 | 1001-960711 | Bearing Mount Assy | 1 |
| 4 | 1001-861722 | Drive Unit Cover | 1 |
| 5 | 1001-861716 | Swing Arm Extension Bracket | 1 |
| 6 | 1001-861717 | Roll Pipe Adapter | 1 |
| 7 | 1001-860704 | Chain Tension Bracket | 1 |
| 8 | 1001-861714 | Bearing Set 1" Bore | 2 |
| 9 | 1001-861719 | Sprocket 40B24 1" Bore | 1 |
| 10 | 1001-861720 | Sprocket 40B10 3/4" Bore | 1 |
| 11 | 1001-861721 | #40 Roller Chain | 1 |
| 12 | 1001-861718 | U-Bolt 2" Swing Arm Mount | 2 |
| 13 | 1001-861723 | Key 1/4" x 1" | 1 |
| 14 | 1001-861724 | Key 3/16" x 1" | 1 |
| 15 | 0815-660660 | 3/8-16 NYLOCK Hex Nut | 4 |
| 16 | 0810-650497 | 1/4-20 x 1/2 FHCS | 9 |
| 17 | 0825-617251 | 1/4-20 x 5/8 SHCS | 6 |
| 18 | 0810-650552 | 5/16-18 x 7/8" Hex Bolt | 9 |
| 19 | 0815-660550 | 5/16-18 NYLOCK Hex Nut | 6 |
| 20 | 0820-680520 | 5/16 Lock Washer | 3 |
| 21 | 0810-650496 | 3/8-16 x 5 FHCS | 1 |
| 22 | 0815-661640 | 3/8-16 Hex Nut | 1 |

Rear Swing Arm

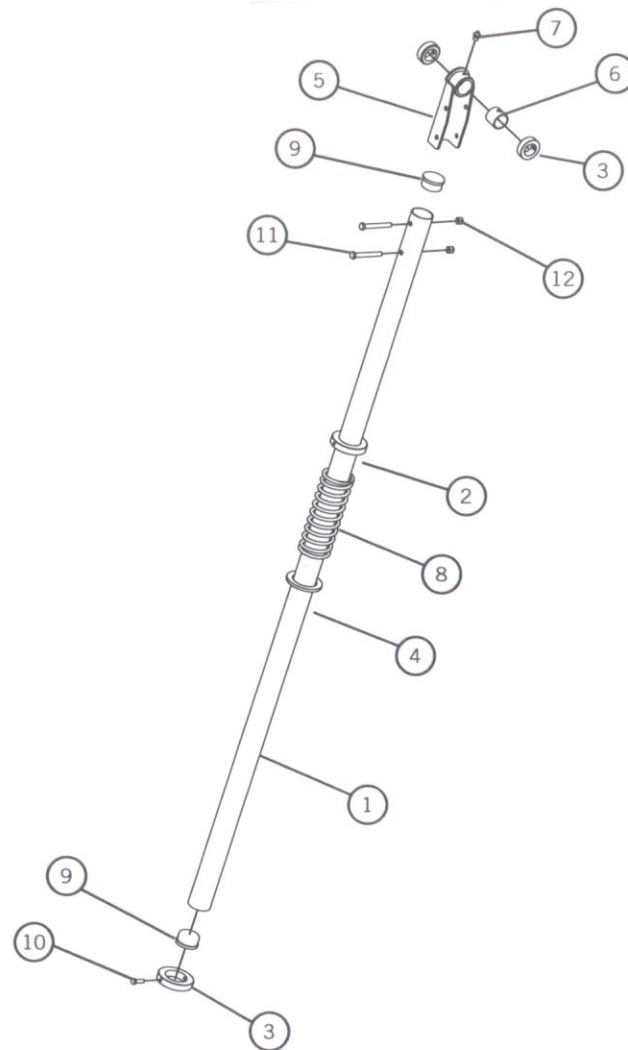

| No. | Part No. | Description | Qty |
|-----|-------------|------------------------------|-----|
| 1 | 1440-281636 | Steel Tube 2" Rd x 6' Lg | 1 |
| 2 | 1001-861316 | Collar Lock Swing Arm | 2 |
| 3 | 0785-690335 | Collar Shaft 1 1/4" ID | 2 |
| 4 | 0820-680401 | Washer 1/4 x 2 1/4 x 3 1/4 | 1 |
| 5 | 1001-962122 | Motor Mount Bracket Assy | 1 |
| 6 | 0845-691233 | Bronze Bushing | 1 |
| 7 | 0825-670394 | Zerk 1/4-28 Straight | 1 |
| 8 | 0715-619405 | Compression Spring Jumbo | 1 |
| 9 | 1001-861308 | Swing Arm Tube Plug-Top | 2 |
| 10 | 0810-650170 | 5/16-18 x 1 Hex Bolt W/Patch | 2 |
| 11 | 0810-670657 | 3/8-16 x 3 Hex Bolt | 2 |
| 12 | 0815-660660 | 3/8-16 NYLOCK Hex Nut | 2 |

Electrical Hardware

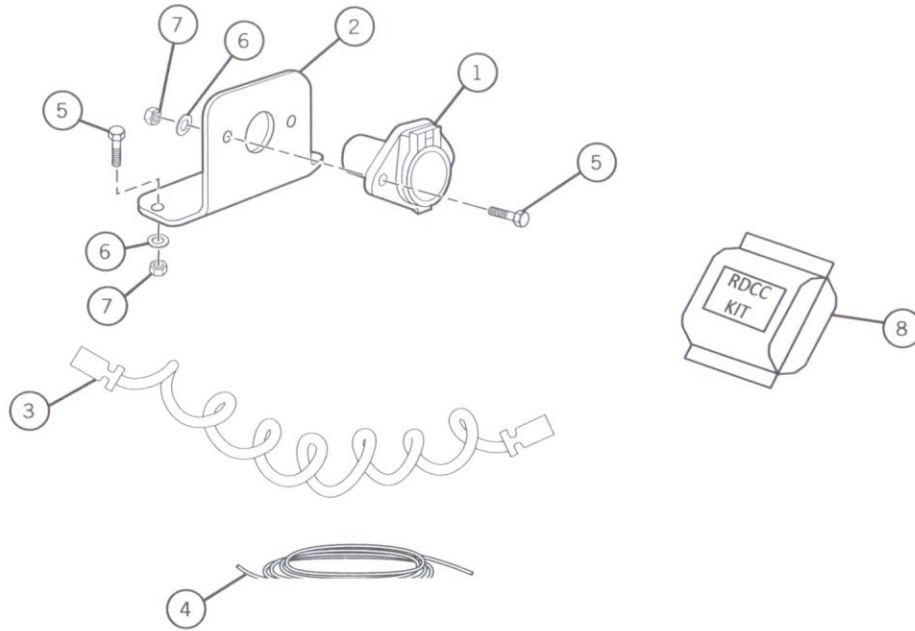

| Electrical Hardware | | | |
|---------------------|-------------|--------------------------|-----|
| No. | Part No. | Description | Qty |
| 1 | 1041-860143 | Female Electrical Socket | 2 |
| 2 | 1001-860165 | Socket Mounting Bracket | 2 |
| 3 | 0755-626434 | Flex Cord with Plugs | 1 |
| 4 | 0755-626540 | #6 Wire (20') | 1 |
| 5 | 0810-650552 | 5/16-18 x 7/8 Hex Bolt | 4 |
| 6 | 0820-680510 | 5/16 Flat Washer | 4 |
| 7 | 0815-660461 | 5/16-18 NYLOCK Hex Nut | 4 |
| 8 | 0755-962108 | RDCC Kit | 1 |

Wiring the Tractor Instructions

There are two items to wire on the tractor before you can operate your Demco side dump. The control box and the tarp power wire.

To install the control box, find a suitable location in the cab of the tractor and mount the control box. The red and black two wire cable attached to the back of the box is the power wire. Plug the cigarette lighter end into a power connection in the cab.

If you do not have an available outlet for the cigarette lighter end, use the following instructions:

- Cut the cigarette lighter plug off.
- Split apart the wires and connect the red wire to a 12v dc power source and the black to ground.

 **Red wire must be positive and Black negative. Reversing these wires can damage the control system.**

- A bag of terminals is included to allow you to tap into most truck fuse panels.

Route the gray cord and male 9 pole plug out of the cab and to the front bulkhead of the side dump. Plug the cord into the female 9 pole socket on the trailer bulkhead. You will now be able to raise and lower the rear axle and dump the tub.

NOTE: Air must be supplied to the side dump for the lift axle to operate properly. Hydraulic oil must be supplied to the side dump to dump the tub.

To use the tarp you will need to supply 12 volt power to the side dump to operate the tarp motor. Due to the large power draw of the tarp motor, the electrical supply must be hooked directly to the battery and the heavy #6 wire included with the kit must be used.

Refer to the Aero wiring diagram for reference. The relay has been already mounted on the side dump and the momentary switch that rolls/unrolls the tarp is in the control box installed previously. All that needs to be done is to run a wire from the battery to the female two pole socket on the road side front corner of the side dump.

Find a suitable location on the tractor to mount the included female two pole socket. A mounting bracket and hardware is also supplied.

Locate the circuit breaker as close to the positive battery post as possible. If the circuit breaker is not mounted to the battery box or truck frame, make sure that the terminals cannot touch anything that would create a short circuit.

Separate enough of the red wire on the #6 red/black cord to reach from the positive battery terminal to the circuit breaker. Cut off the red wire. Strip the red wire and crimp on ring terminals to match the battery cable bolt and the post on the circuit breaker.

 **Do Not hook the red wire to the battery until everything else is wired.**

Crimp a ring terminal on the red wire on the remaining red/black cord and attach it to the circuit breaker.

Crimp a ring terminal on the black wire and attach it to the negative battery post.

Route the red/black cord to the female socket. Cut the cord and crimp ring terminals on the end of the wires.

Slip the cover for the back of the socket over the cord and bolt the ring terminals to the socket. Match the positive and negative wires to the corresponding terminals marked on the socket.

Slip the cover over the back of the socket. Secure the red/black cord to the truck frame.

Hook the red wire to the battery. A double male stretch cord is included to connect the tractor to the side dump.

The tarp will now operate from the control box. It is best to have the tractor running while operating the tarp.

Mounting Parts

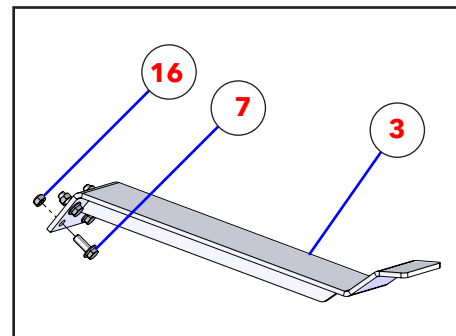
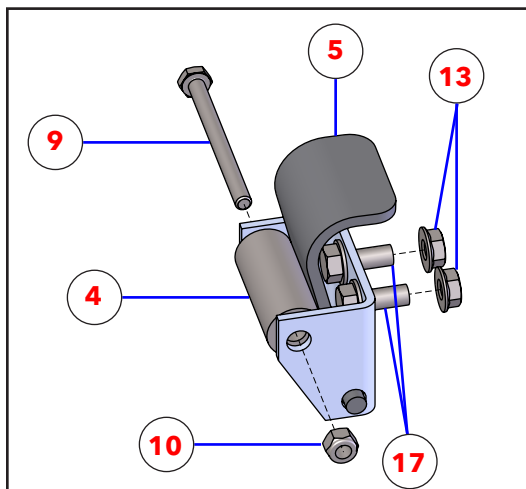
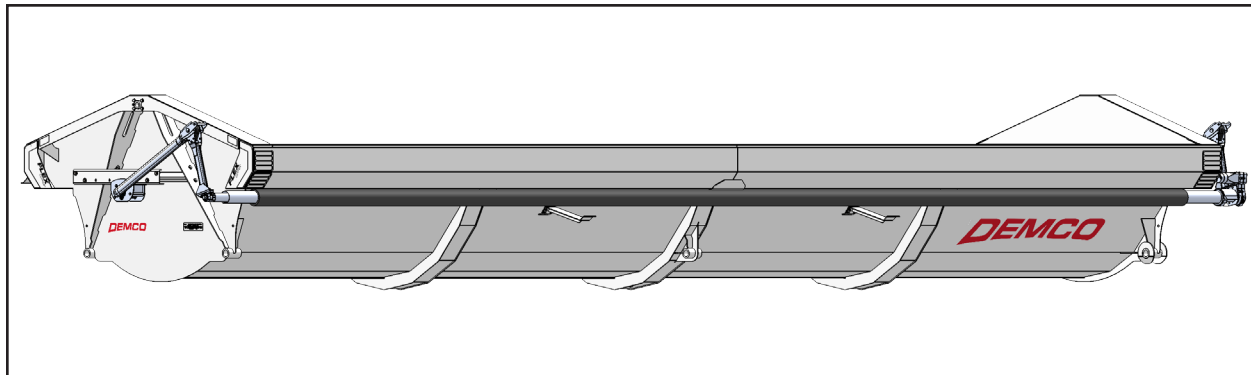
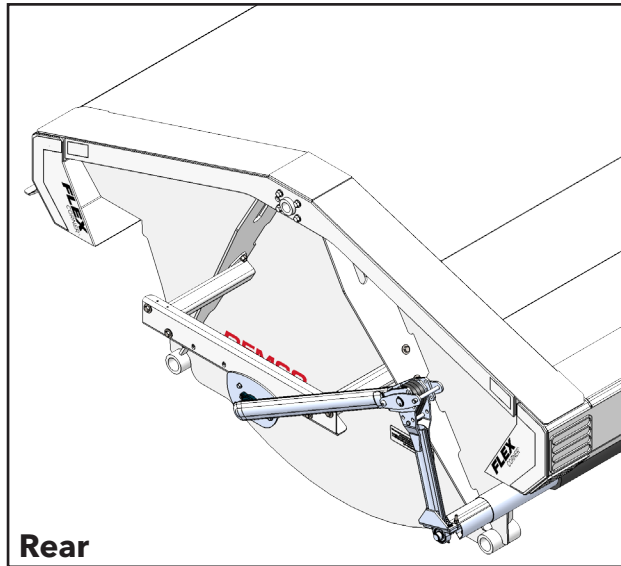
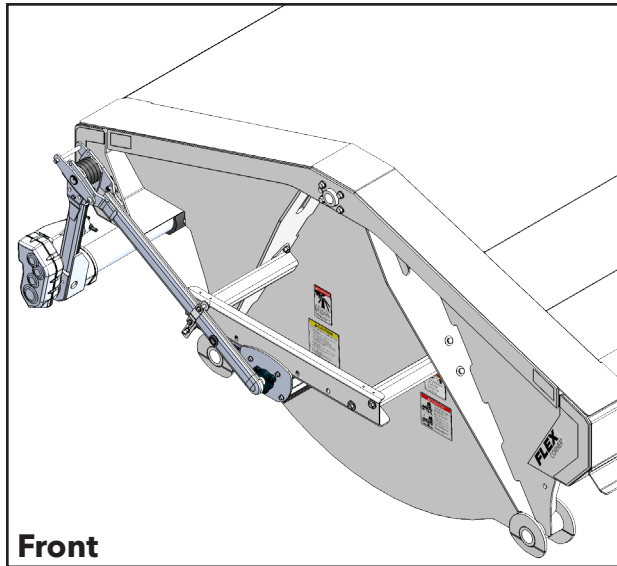

Mounting Parts

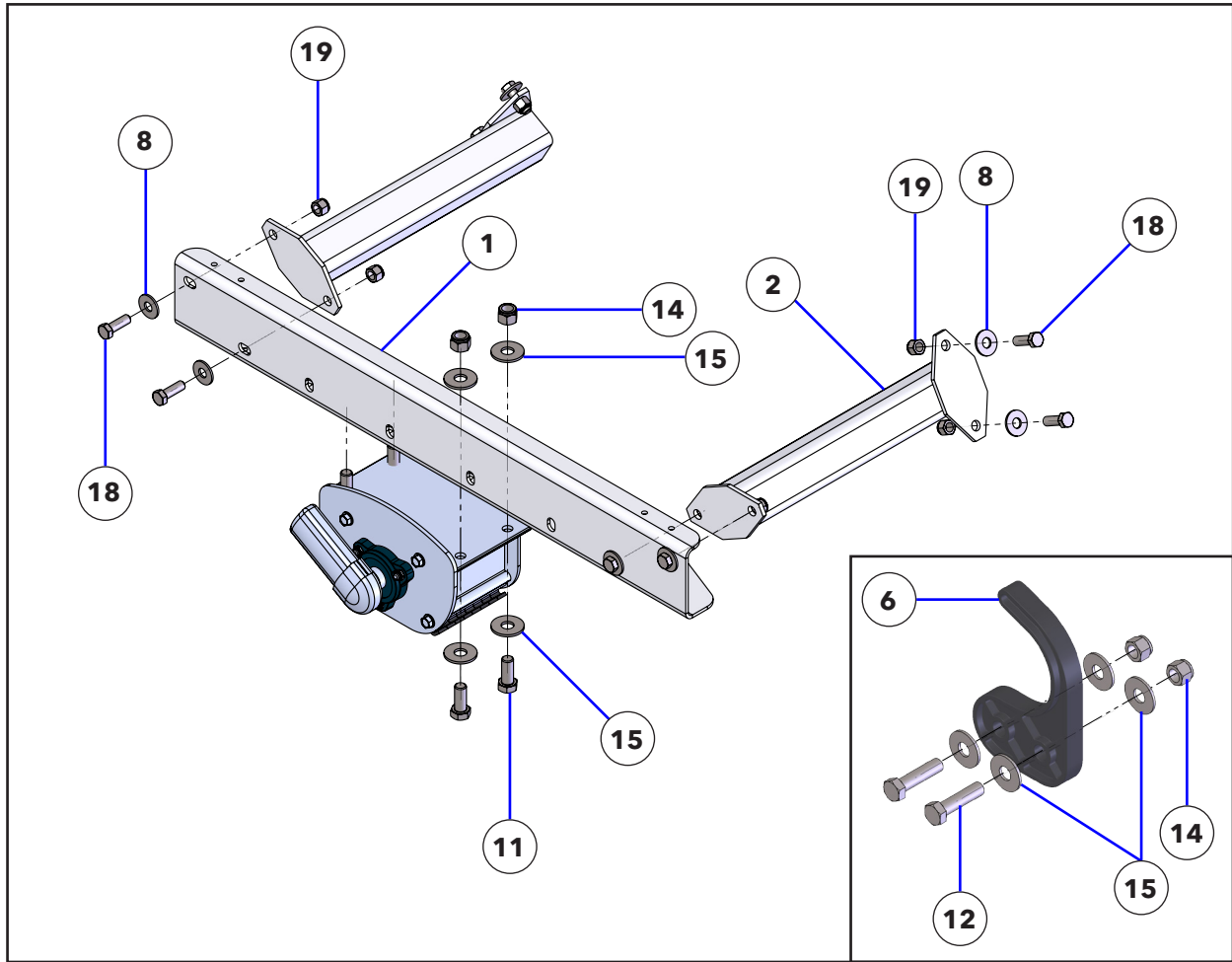

| BOM ID | Qty | Item No | Description |
|--------|-----|-------------|---|
| 1 | 2 | 3CAM9385 | TARP MOUNTING CHANNEL |
| 2 | 4 | 5CAM9038 | TARP CHANNEL MOUNT |
| 3 | * | 5C000008 | BRACKET, TARP SUPPORT |
| 4 | * | 1AUAM9073 | SPACER, TARP MOUNTING, 7/8" OD X 11/32" ID X 2" OAL |
| 5 | * | 1AZAP4108 | CLAMP, STEEL CLAMP FOR TARP SECURING ROD PLTD, EA (36830) |
| 6 | 2 | 1AZAP4152 | TARP HOOK, PLASTIC, ROLLRITE, EA (36840) |
| 7 | * | 1AFC12FAA05 | HEX CAP SCREW, 3/8"-16 X 1", GR 5, PLTD |
| 8 | 16 | 1AF009H0000 | WASHER, FLAT, 1/2", PLTD |
| 9 | * | 1AFBP3588 | HEX CAP SCREW, 1/4"-20 X 3", GR 8, PLTD |
| 10 | * | 1AFC18D0000 | NUT, HEX LOCK, 1/4"-20, NYLOCK, PLTD |
| 11 | 4 | 1AFC12JAAH5 | HEX CAP SCREW, 5/8"-11 X 1-1/2", GR 5, PLTD |
| 12 | 4 | 1AFC12JBAH5 | HEX CAP SCREW, 5/8"-11 X 2-1/2", GR 5, PLTD |
| 13 | * | 1AFC08E0000 | NUT, HEX SERRATED FLANGE, 5/16"-18, PLTD |
| 14 | 12 | 1AFC18J0000 | NUT, HEX LOCK, 5/8"-11, NYLOCK, PLTD |
| 15 | 16 | 1AF009J0000 | WASHER, FLAT, 5/8", PLTD |
| 16 | * | 1AFBP3612 | NUT, HEX LOCK, 3/8"-16, TOP LOCK, PLTD |
| 17 | * | 1AFC37E00L0 | HEX CAP SCREW, 5/16"-18 X 3/4", SERRATED FLANGE HD, PLTD |
| 18 | 16 | 1AFC12HAAH8 | HEX CAP SCREW, 1/2"-13 X 1-1/2" GR 8, PLTD |
| 19 | 16 | 1AFC18H0000 | NUT, HEX LOCK, 1/2"-13, NYLOCK, PLTD |

* Quantities vary by tub length.

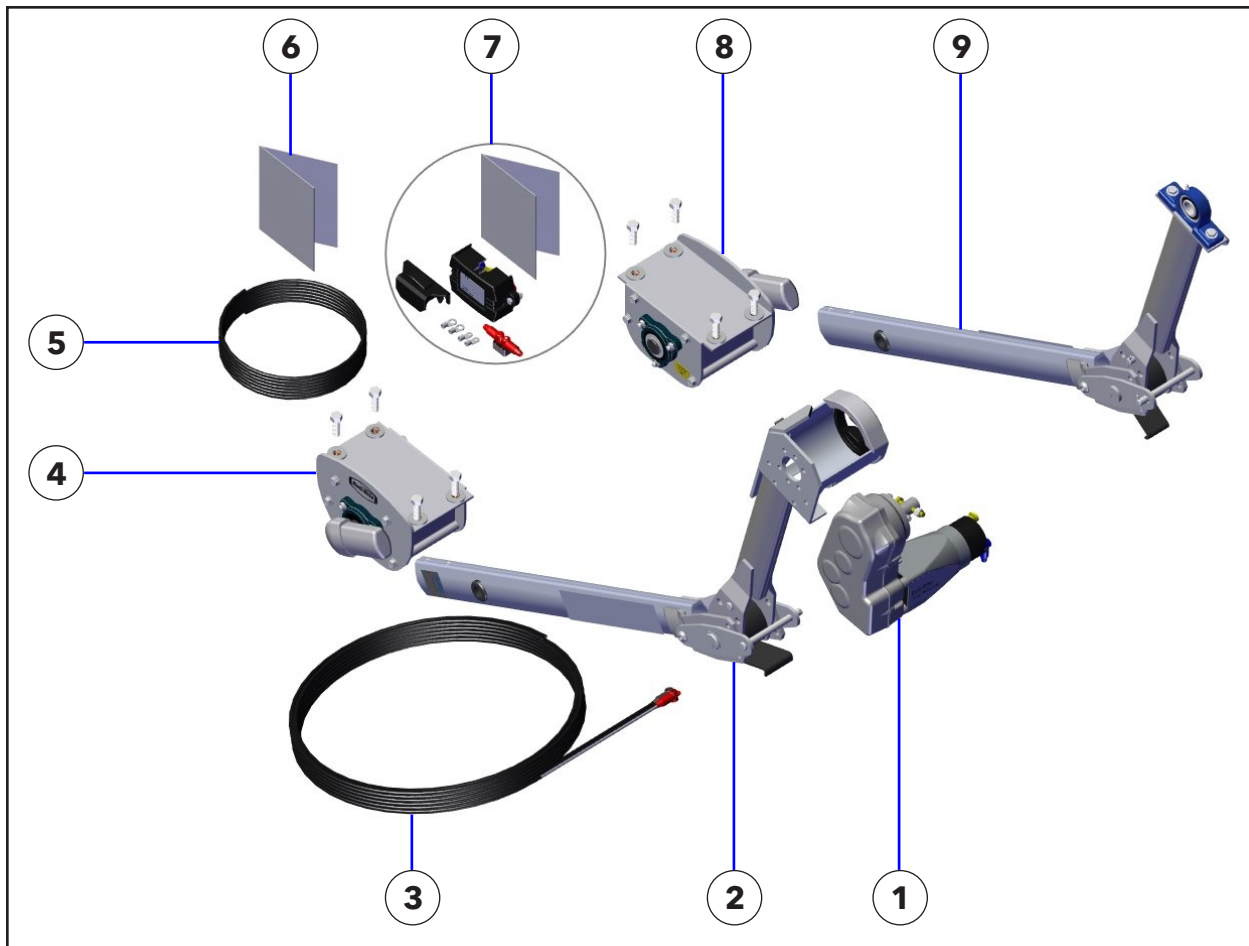

| 1AZAP3576 (Rite-Lock Power Arm Kit, Pass. Side Stowing for Side Dump 12VTS) | | | |
|--|-----|-------------|--|
| BOM ID | Qty | Item No | Description |
| 1 | 1 | 1AZAP4293 | MOTOR, ROLL RITE TARP (10200) |
| 2 | 1 | - | PIVOT, ASSY FRONT 4-SPRING KNUCKLE ARM, MOTOR END (46802) |
| 3 | 1 | 1AEW000WF62 | PARALLEL BAT CABLE, 6GA, BLK W/RED (11330) |
| 4 | 1 | - | PIVOT, UB ASSEMBLED STS 8-SPR FRONT (102354) |
| 5 | 1 | 1AZAP4295 | CABLE, 16GA / 3COND, BLU/YEL/RED, 15' (11411) |
| 6 | 1 | - | INSTRUCTIONS, UNIVERSAL STS DUMP SYSTEM (102317) |
| 7 | 1 | 1AZ00103460 | ELECTRIC KIT, TSCM W/ SS GEN1+ RELAY & ROCKER SW, 6GA (103460) |
| 8 | 1 | - | PIVOT, UB ASSEMBLED STS 8-SPR REAR (102353) |
| 9 | 1 | - | PIVOT, ASSY REAR KNUCKLE ARM, NON-MOTOR END (46803) |

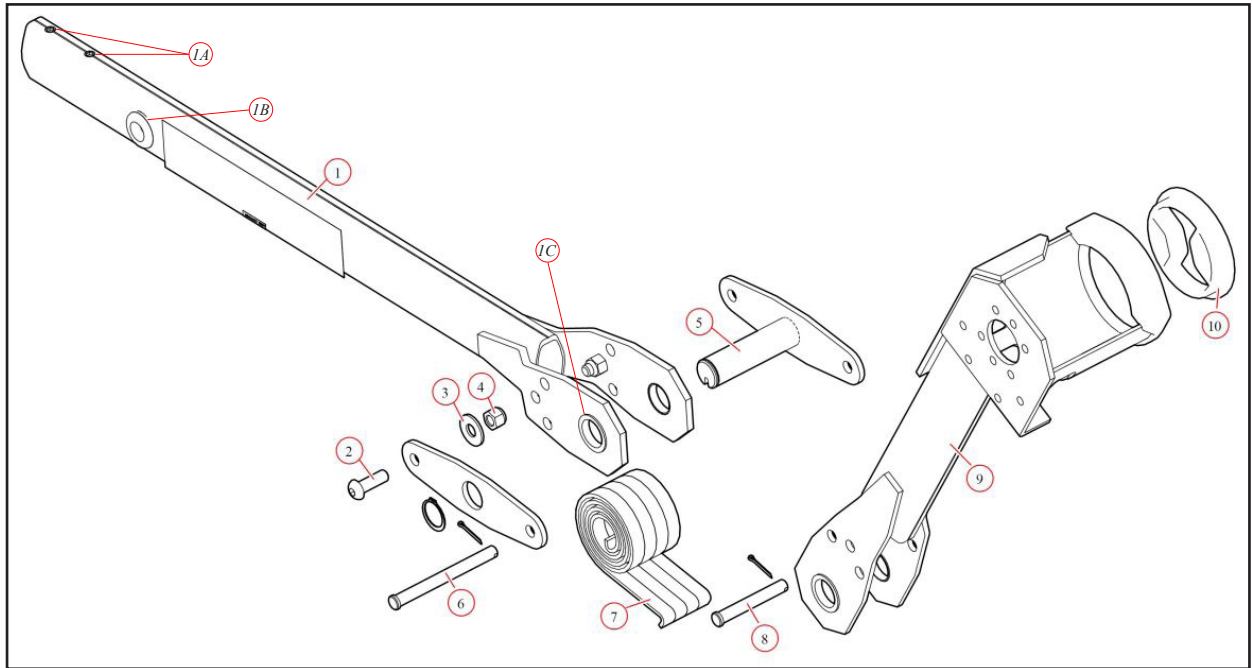

Pivot, Assy Front 4-Spring Knuckle Arm, Motor End (46802)

| BOM ID | Qty | Item No | Description |
|--------|-----|-------------|--|
| * 1 | 1 | - | PIVOT TUBE, BASE W/SIDE PLATES, 4 SPRING STS KNUCKLES (102199) |
| 1A | 1 | - | SCREW, 1/2" X 5/8" SET (18291) |
| 1B | 1 | - | GROMMET, RUBBER 7/8 ID X 1/8 GROOVE FOR TOP MT PIVOTS (16419) |
| 1C | 1 | - | BUSHING, 1-1/4 POLY T-BUSHING FOR PIVOT PIN (47040) |
| 2 | 2 | - | BOLT, 1/2" X 1-1/2" BUTTON HEAD PLTD (18295) |
| 3 | 2 | 1AF009H0000 | WASHER, 1/2" FLAT PLTD (18412) |
| 4 | 2 | 1AFC18H0000 | NUT, 1/2" NYLOCK NUT PLTD (18631) |
| 5 | 1 | - | BRACKET, 4-SP KNUCKLE W/STOP PLATE FOR STS MOTOR END (47970) |
| 6 | 1 | - | PIN, 1/2" X 5-1/4" CLEVIS (18540) |
| 7 | 4 | 1AZAP4589 | SPRING, SPIRAL TORSION 1-1/4" (47230) |
| 8 | 1 | 1AFAP4507 | PIN, 1/2" X 3-1/2" CLEVIS (18520) |
| 9 | 1 | - | PIVOT TUBE, FRONT UPPER FOR 4-SP KNUCK W/BUSH 13.06" (102197) |
| 10 | 1 | 1AZAP4539 | BUSHING, AXLE STABILIZER FOR 4" AXLE (37580) |

* Note: All High Capacity Kits require longer lower tarp arms see page 66 for High Capacity specific tarp parts.

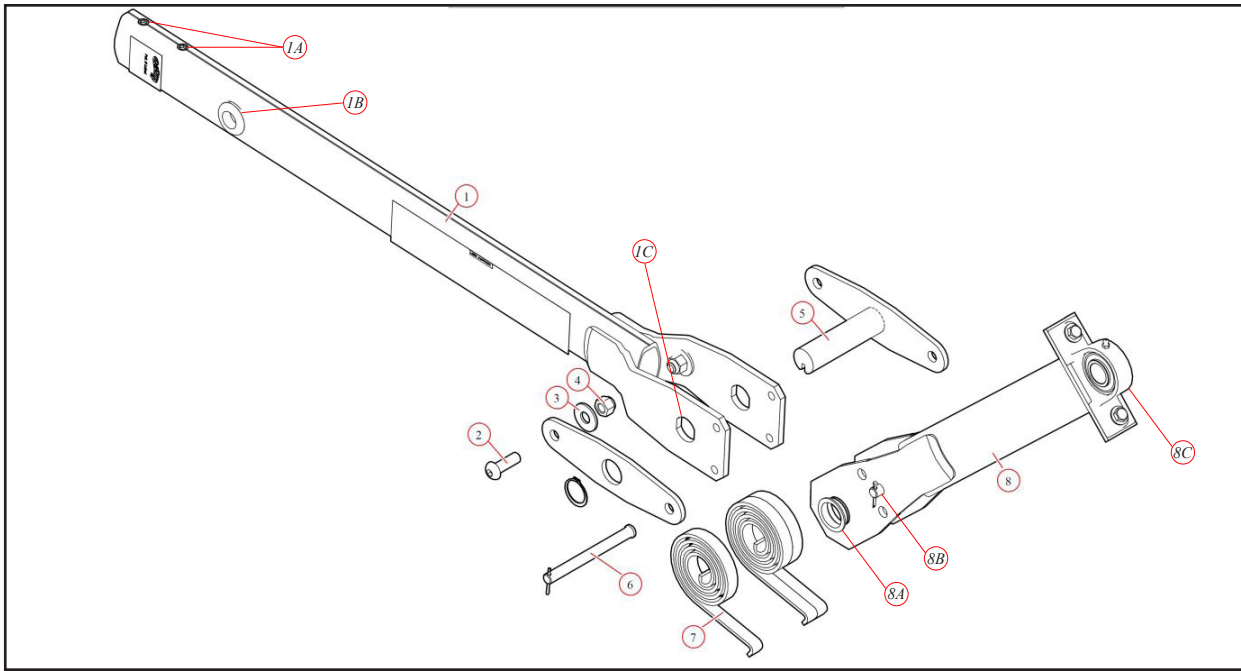

Pivot, Assy Rear Knuckle Arm, Non-Motor End (46803)

| BOM ID | Qty | Item No | Description |
|--------|-----|-------------|--|
| * 1 | 1 | - | PIVOT TUBE, BASE W/SIDE PLATES, 4-SPRING STS KNUCKLES (102199) |
| 1A | 1 | - | SCREW, 1/2" X 5/8" SET (18291) |
| 1B | 1 | - | GROMMET, RUBBER 7/8 ID X 1/8 GROOVE FOR TOP MT PIVOTS (16419) |
| 1C | 1 | - | BUSHING, 1-1/4 POLY T-BUSHING FOR PIVOT PIN (47040) |
| 2 | 2 | - | BOLT, 1/2" X 1-1/2" BUTTON HEAD PLTD (18295) |
| 3 | 2 | 1AF009H0000 | WASHER, 1/2" FLAT PLTD (18412) |
| 4 | 2 | 1AFC18H0000 | NUT, 1/2" NYLOCK NUT PLTD (18631) |
| 5 | 1 | - | BRACKET, 4-SP KNUCKLE W/STOP PLATE FOR STS MOTOR END (47970) |
| 6 | 1 | - | PIN, 1/2" X 5-1/4" CLEVIS (18540) |
| 7 | 4 | 1AZAP4589 | SPRING, SPIRAL TORSION 1-1/4" (47230) |
| 8 | 1 | - | PIVOT TUBE, REAR UPPER FOR 4-SP KNUCKLE W/BEARING (47890) |
| 8A | 1 | - | BUSHING, 1-1/4 POLY T-BUSHING FOR PIVOT PIN (47040) |
| 8B | 1 | 1AFAP4507 | PIN, 1/2" X 3-1/2" CLEVIS (18520) |
| 8C | 1 | 1AZ31050000 | BEARING, PILLOW BLOCK (31055) |

* Note: All High Capacity Kits require longer lower tarp arms see page 66 for High Capacity specific tarp parts.

| Pivot, UB Assembled STS 8-Spr Front (102354) | | | |
|---|-----|-------------|---|
| BOM ID | Qty | Item No | Description |
| 1 | 1 | - | PIVOT PIN, FOR 8-SPR ROLLER BEARING PIV, DRIVER SIDE (47400) |
| 2 | 2 | - | BEARING, CARRIER UNDERBODY FLANGED (47800) |
| 2A | 3 | 1AFC18F0000 | NUT, 3/8" NYLOCK NUT PLTD (18628) |
| 2B | 3 | 1AFBP3633 | BOLT, 3/8-16 X 1-1/8", BUTTON HEAD, PLTD (18242) |
| 3 | 8 | 1AZAP4589 | SPRING, SPIRAL TORSION 1-1/4" (47230) |
| 4 | 8 | 1AFC37FAAH5 | BOLT, 3/8 X 1-1/2", THREAD-CUTTING SCREW, HEX WASHER HD (18120) |
| 5 | 1 | - | PLATE, AL FRONT FOR EXT BOLT FLANGE MOUNT UB BOX (102349) |
| 6 | 1 | - | BRACKET, EXT BODY WITH HOLES FOR 8-SPR UB BOX (102269) |
| 7 | 1 | - | PLATE, AL BACK FOR EXT BOLT FLANGE MOUNT UB BOX (102259) |

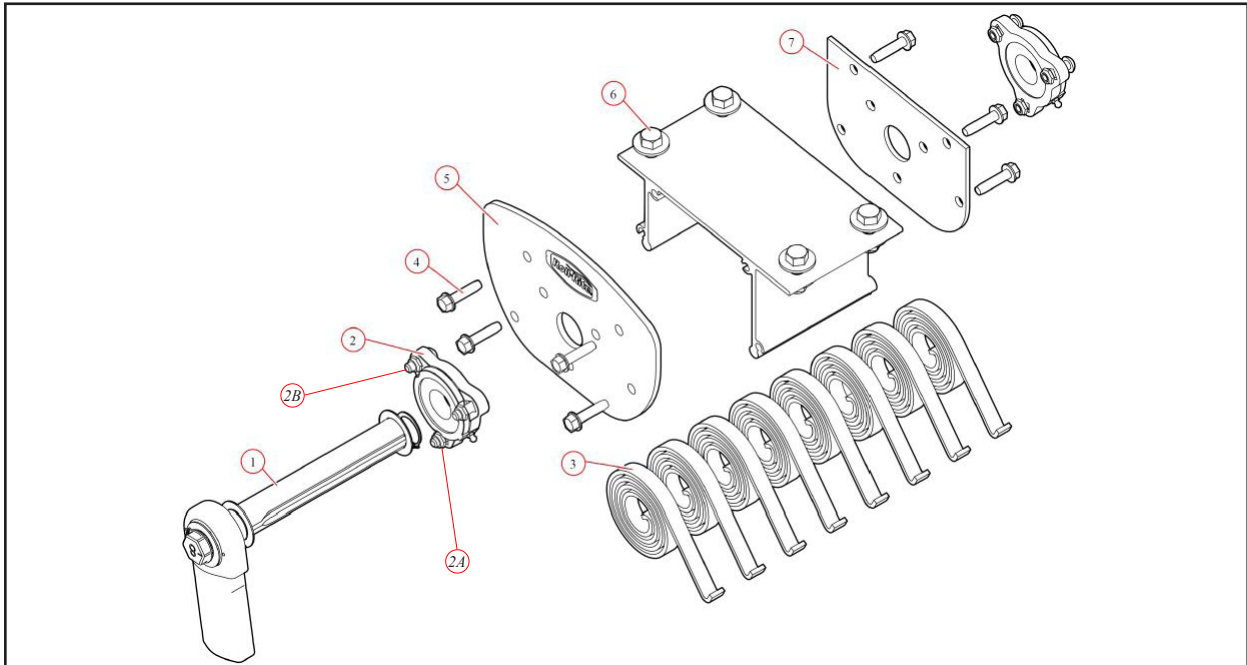

| Pivot, UB Assembled STS 8-Spr Rear (102353) | | | |
|--|-----|-------------|---|
| BOM ID | Qty | Item No | Description |
| 1 | 1 | - | PIVOT PIN, FOR 8-SPR ROLLER BEARING PIV, PASS SIDE (47410) |
| 2 | 2 | - | BEARING, CARRIER UNDERBODY FLANGED (47800) |
| 2A | 3 | 1AFC18F0000 | NUT, 3/8" NYLOCK NUT PLTD (18628) |
| 2B | 3 | 1AFBP3633 | BOLT, 3/8-16 X 1-1/8", BUTTON HEAD, PLTD (18242) |
| 3 | 8 | 1AZAP4589 | SPRING, SPIRAL TORSION 1-1/4" (47230) |
| 4 | 8 | 1AFC37FAAH5 | BOLT, 3/8 X 1-1/2", THREAD-CUTTING SCREW, HEX WASHER HD (18120) |
| 5 | 1 | - | PLATE, AL FRONT FOR EXT BOLT FLANGE MOUNT UB BOX (102349) |
| 6 | 1 | - | BRACKET, EXT BODY WITH HOLES FOR 8-SPR UB BOX (102269) |
| 7 | 1 | - | PLATE, AL BACK FOR EXT BOLT FLANGE MOUNT UB BOX (102259) |

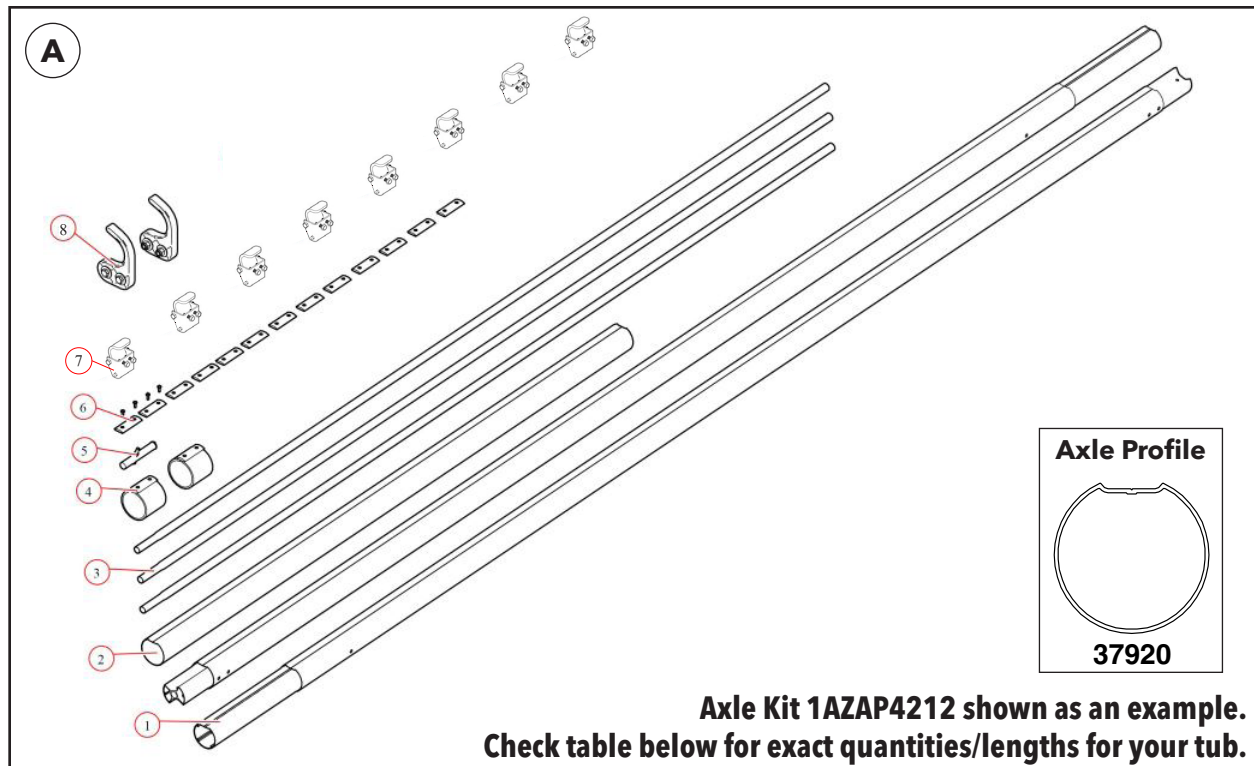

| Tub Length | Axle Kit Item No | Axle Tube Length | Fixed Tarp Rod Length | Axle Tarp Clips (C/C) | Tarp Rod Clamps (1AZAP4108) |
|------------|------------------|------------------|-----------------------|-----------------------|-----------------------------|
| 14' | 1AZAP4279 | 17' - 2 1/2" | 13' - 8 1/4" | 6 (32") | 6 |
| 15' | 1AZAP4279 | 18' - 2 1/2" | 14' - 8 1/4" | 6 (34") | 6 |
| 16' | 1AZAP4279 | 19' - 3" | 15' - 8 3/4" | 6 (36") | 6 |
| 17' | 1AZAP4459 | 20' - 2 1/2" | 16' - 8 1/4" | 6 (38") | 6 |
| 20' | 1AZAP4459 | 23' - 3" | 19' - 9 1/4" | 7 (38") | 6 |
| 24' | 1AZAP4410 | 27' - 3" | 23' - 9" | 10 (32") | 6 |
| 30' | 1AZAP4212 | 33' - 6" | 30' - 0 3/8" | 11 (36") | 8 |
| 34' | 1AZAP4212 | 37' - 6" | 34' - 0 1/2" | 11 (40") | 8 |
| 37' | 1AZAP4563 | 40' - 3" | 36' - 9 1/4" | 11 (44") | 8 |

| BOM ID | Qty | Item No | Description |
|--------|-----|-----------|--|
| 1 | | - | AXLE, 4" UNIVERSAL FRONT/REAR SECTION FOR SIDE DUMP (37920) |
| 2 | | - | EXTRUSION, 4" AXLE, 98" (102367) |
| 3 | | - | STEEL TUBING, 1.125D X 16GA X 12' RND GALV W/SWEDGE (101815) |
| 4 | 2 | - | AXLE SLEEVE, SIDE DUMP BELT STYLE, AXLE SLEEVE KIT (102379) |
| 5 | 1 | - | HARDWARE, STUB SHAFT KIT FOR SIDE DUMP SYSTEM (102365) |
| 6 | | - | CLIP, TARP CLIP W/HARDWARE FOR STS AXLE (37830) |
| 7 | | 1AZAP4108 | CLAMP, STEEL CLAMP FOR TARP SECURING ROD PLTD, EA (36830) |
| 8 | 2 | 1AZAP4152 | TARP HOOK , PLASTIC, ROLLRITE, EA (36840) |

| Tub Length | Tarp Kit | Mesh Tarp | Tarp Size |
|------------|-----------|-------------|----------------|
| 14' | 1AZAP3576 | 1AZAP4598 | 13'-6" x 162" |
| 15' | 1AZAP3576 | 1AZAP4599 | 14'-6" x 162" |
| 16' | 1AZAP3576 | 1AZAP4600 | 15'-6" x 162" |
| 17' | 1AZAP3576 | 1AZAP4601 | 16'-6" x 162" |
| 20' | 1AZAP3576 | 1AZAP4602 | 19'-7" x 162" |
| 24' | 1AZAP3576 | 1AZJ23800RE | 23'-8" x 162" |
| 30' | 1AZAP3576 | 1AZAP4603 | 29'-10" x 162" |
| 34' | 1AZAP3576 | 1AZAP4604 | 33'-10" x 162" |
| 37' | 1AZAP3576 | 1AZAP4605 | 36'-7" x 162" |

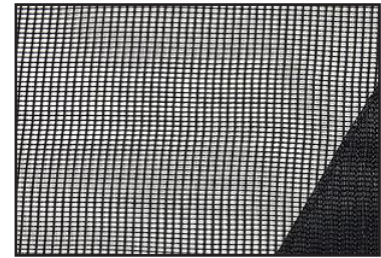

Mesh Tarp

Roll-Rite Electric Tarp Parts for High-Capacity Kits Only

| Tub Length | Axle Kit | Tarp Kit | Mesh Tarp | Tarp Size | Axle Tube Length | Fixed Tarp Rod Length |
|------------|-----------|-----------|-----------|------------|------------------|-----------------------|
| 20' H.C. | 1AZAP4459 | 1AZAP4402 | - | 20' x 147" | 23' - 3" | 20' - 1 3/4" |
| 24' H.C. | 1AZAP4410 | 1AZAP4402 | 1AZAP4409 | 24' x 147" | 27' - 3" | 24' - 1 1/2" |
| 34' H.C. | 1AZAP4212 | 1AZAP4402 | 1AZAP3950 | 34' x 147" | 37' - 6" | 34' - 4 3/4" |
| 37' H.C. | 1AZAP4563 | 1AZAP4402 | 1AZAP4562 | 37' x 147" | 40' - 3" | 37' - 1 3/4" |

Note: All High Capacity Kits, including XL Kits, use the same quantity and spacing of Axle Tarp Clips and Tarp Rod Clamps as standard tubs. Longer lower tarp arms are required for all High Capacity Kits - use Item Number 1AZ102266RE (ROLL-RITE HIGH CAPACITY TARP ARM, EA, #102266).

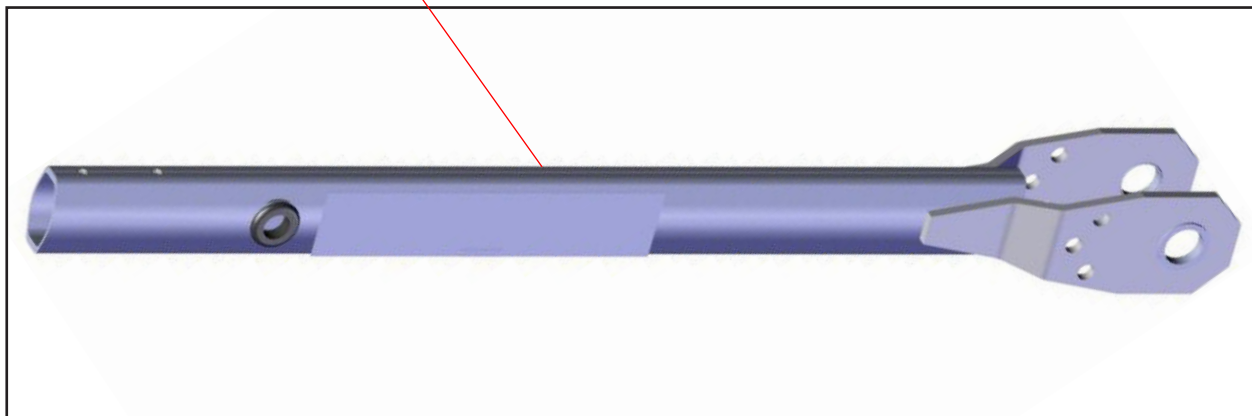

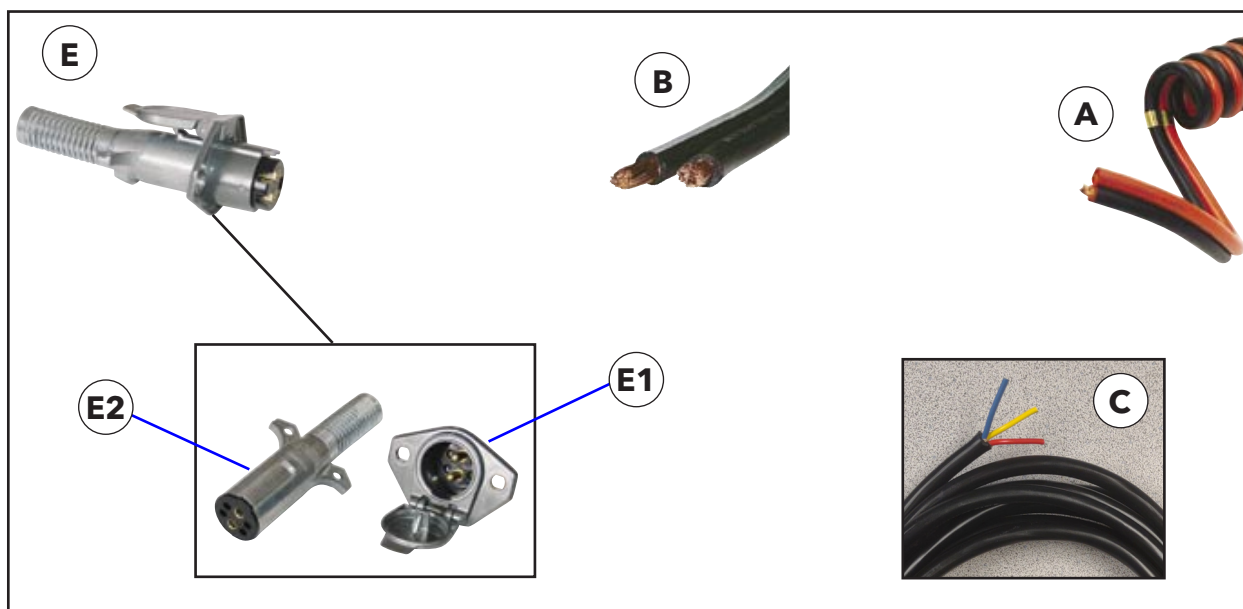
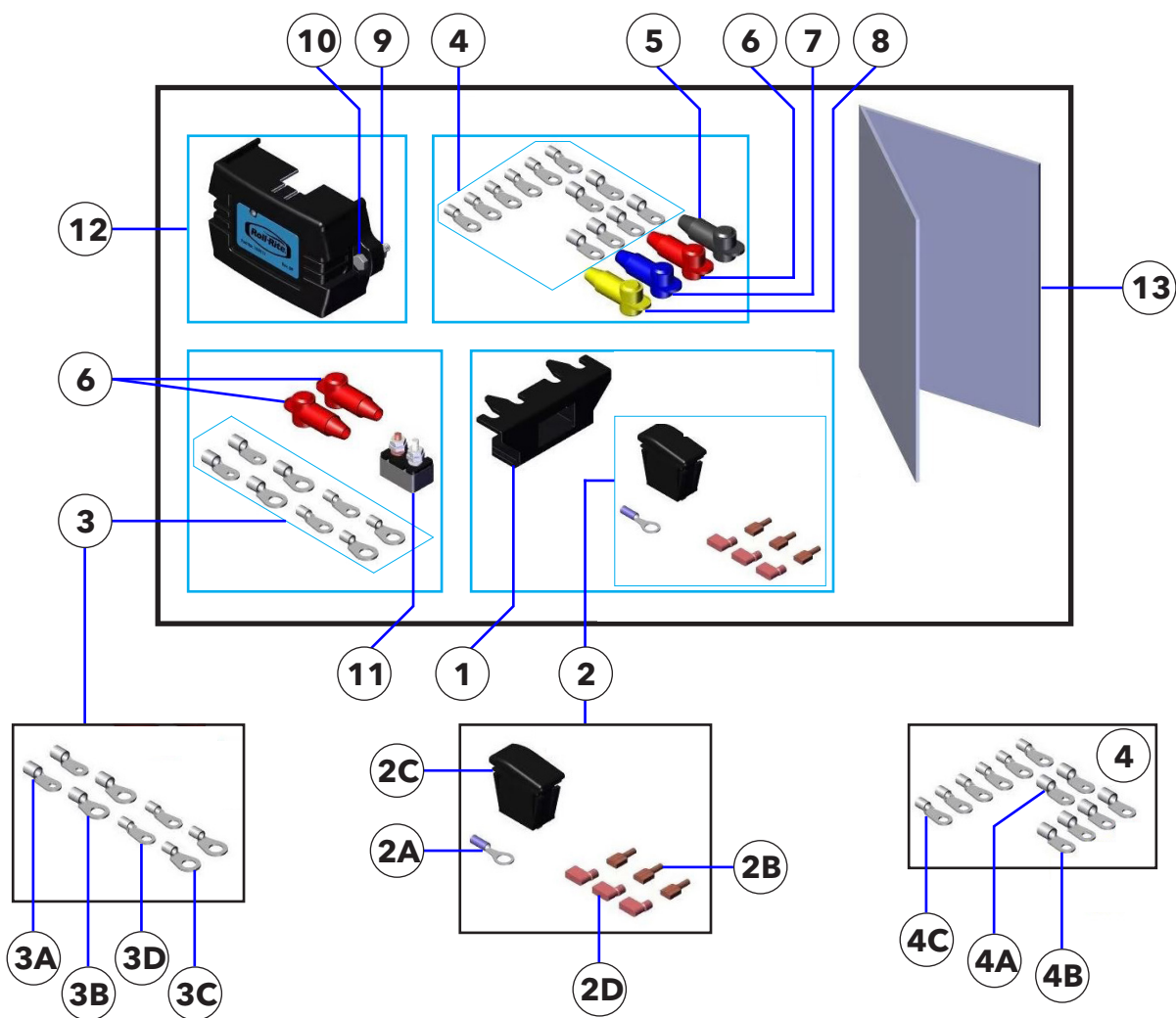

ELECTRIC TARP OPTION -- ROLL-RITE

| 1AZ00103460 (Electric Kit, TSCM W/SS Gen1+ Relay & Rocker Switch, 6GA) | | | |
|---|-----|-------------|--|
| BOM ID | Qty | Item No | Description |
| 1 | 1 | 1AZ00010390 | MOUNT BRACKET, ROCKER SWITCH (10390) |
| 2 | 1 | - | ROCKER SWITCH KIT (10915) |
| 2A | 1 | 1AEC0031506 | TERMINAL, 14 GA INSULATED, 3/8" RING (16080) |
| 2B | 3 | - | TERMINAL, 18 GA INSULATED, Q.D. FEMALE (16118) |
| 2C | 1 | 1AZ00019300 | SWITCH, ROCKER (OPEN/CLOSE) (19300) |
| 2D | 3 | - | TERMINAL, 14-16 GA INSULATED, Q.D. FLAG FEMALE (100460) |
| 3 | 1 | - | TERMINAL KIT FOR CIRC. BREAKER, 6/8 GA TERMINALS (10918) |
| 3A | 2 | - | TERMINAL, 6 GA, #10 RING (16020) |
| 3B | 2 | 1AEC0036073 | TERMINAL, 6 GA, 3/8" RING (16030) |
| 3C | 2 | - | TERMINAL, 8 GA, 3/8" RING (16150) |
| 3D | 2 | 1AEC0033002 | TERMINAL, 8 GA, 1/4" RING (16155) |
| 4 | 1 | - | TERMINAL KIT FOR SS RELAY, 6/8 GA TERMINALS (10919) |
| 4A | 2 | - | TERMINAL, 6 GA, #10 RING (16020) |
| 4B | 4 | 1AEC0036071 | TERMINAL, 6 GA, 1/4" RING (16021) |
| 4C | 6 | 1AEC0033002 | TERMINAL, 8 GA, 1/4" RING (16155) |
| 5 | 1 | - | TERMINAL BOOT, BLACK, 8-2GA (16200) |
| 6 | 3 | - | TERMINAL BOOT, RED, 8-2GA (16201) |
| 7 | 1 | - | TERMINAL BOOT, BLUE, 8-2GA (16202) |
| 8 | 1 | - | TERMINAL BOOT, YELLOW, 8-2GA (16203) |
| 9 | 2 | 1AFC08D0000 | HEX NUT, 1/4-20 FLANGE, SERRATED, PLTD (18620) |
| 10 | 2 | 1AFC12DAA05 | HEX BOLT, 1/4-20 X 1", GR5, PLTD (18700) |
| 11 | 1 | 1AZ00101259 | 50A MANUAL RESET CIRCUIT BREAKER, RITE TOUCH (101259) |
| 12 | 1 | 1AZ00103238 | 12V RITE TOUCH RELAY SS GEN1+ W/HOUSING (103238) |
| 13 | - | - | ELECTRICAL COMPONENT INSTALLATION GUIDE (105568) |

TO ADD TARP CONTROLS TO A SECOND TRACTOR FOR A STANDARD HYDRAULIC SIDE DUMP, SEE YOUR DEALER FOR COMPLETE KIT AND PRICING FOR 4CFK2014 (KIT, ROLL-RITE TARP, CONTROL SWITCH FOR 2ND TRACTOR). FOR EOH TRAILERS, SEE PAGE 43.

| Other Electrical Components for Roll-Rite Tarps | | | |
|--|-----|-------------|---|
| BOM ID | Qty | Item No | Description |
| A | - | 1AZ00011320 | 6GA DUAL COILED CORD (11320) |
| B | - | 1AEW000WF62 | PARALLEL BAT CABLE, 6GA, BLK W/RED (11330) |
| C | - | 1AZAP4295 | CABLE, 16GA / 3COND, BLU/YEL/RED, 15' (11411) |
| E | - | 1AZAP4211 | MALE & FEMALE PLUG SET, 2-PIN, ROLL-RITE TARP (12760) |
| E1 | 1 | 1AZAP4236 | FEMALE PLUG, 2-PIN, ROLL-RITE TARP (12770) |
| E2 | 1 | 1AZAP4235 | MALE PLUG, 2-PIN, ROLL-RITE TARP (12780) |

**Roll-Rite Generation 1+ Solid State Reversing Relay with Rocker Switch
(Tarp Uncovering to the right of driver)**

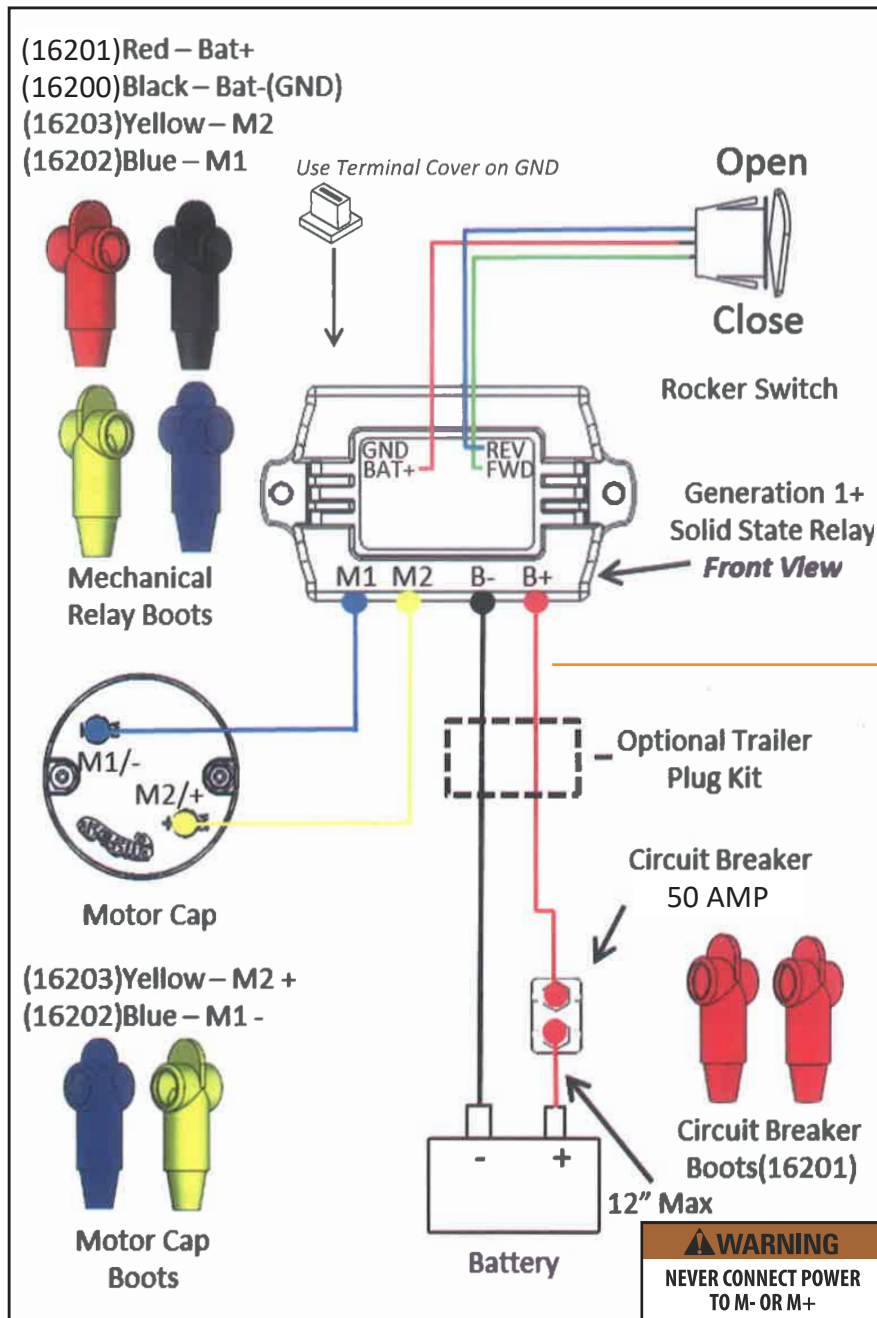

⚠ WARNING

Note: After installation, the terminals on the B+ circuit contain un-switched 12V energy at all times. Installation requirements must be followed to avoid contact between these terminals and chassis ground.

Wiring the Tractor

There are two items to wire on the tractor before you can operate your Demco side dump. The control box and the tarp power wire.

To install the control box, find a suitable location in the cab of the tractor and mount the control box. The red and black two wire cable attached to the back of the box is the power wire. Plug the cigarette lighter end into a power connection in the cab.

If you do not have an available outlet for the cigarette lighter end, use the following instructions:

- Cut the cigarette lighter plug off.
- Split apart the wires and connect the red wire to a 12v dc power source and the black to ground.
-  - **Red wire must be positive and Black negative. Reversing these wires can damage the control system.**
- A bag of terminals is included to allow you to tap into most truck fuse panels.

Route the gray cord and male 9 pole plug out of the cab and to the front bulkhead of the side dump. Plug the cord into the female 9 pole socket on the trailer bulkhead. You will now be able to raise and lower the rear axle and dump the tub.

NOTE: Air must be supplied to the side dump for the lift axle to operate properly. Hydraulic oil must be supplied to the side dump to dump the tub.

To use the tarp you will need to supply 12 volt power to the side dump to operate the tarp motor. Due to the large power draw of the tarp motor, the electrical supply must be hooked directly to the battery and the heavy #6 wire included with the kit must be used.

Refer to the Roll Rite wiring diagram for reference. The relay has been already mounted on the side dump and the momentary switch that rolls/unrolls the tarp is in the control box installed previously. All that needs to be done is to run a wire from the battery to the female two pole socket on the road side front corner of the side dump.

Locate the circuit breaker as close to the positive battery post as possible. If the circuit breaker is not mounted to the battery box or truck frame, make sure that the terminals cannot touch anything that would create a short circuit. See image on next page for installation orientation of circuit breaker.

Separate enough of the white wire on the #6 white/black cord to reach from the positive battery terminal to the circuit breaker. Cut off the white wire. Strip the white wire and crimp on ring terminals to match the battery cable bolt and the post on the circuit breaker.



Do not hook the white wire to the battery until everything else is wired.

Crimp a ring terminal on the white wire on the remaining white/black cord and attach it to the circuit breaker.

Crimp a ring terminal on the black wire and attach it to the negative battery post.

Route the white/black cord to the female socket on the side dump. Cut the cord and strip the ends back to slip into the terminals on the back of the male 2 pin plug. Match the white and black wires to the corresponding wires in the side dump socket. You may need to slip the cover off the back of the socket to make sure that the wires match up. Secure the white/black cord to the truck frame.

Hook the white wire to the battery.

The tarp will now operate from the control box. It is best to have the tractor running while operating the tarp.

REAR ATTACHMENT OPTIONS

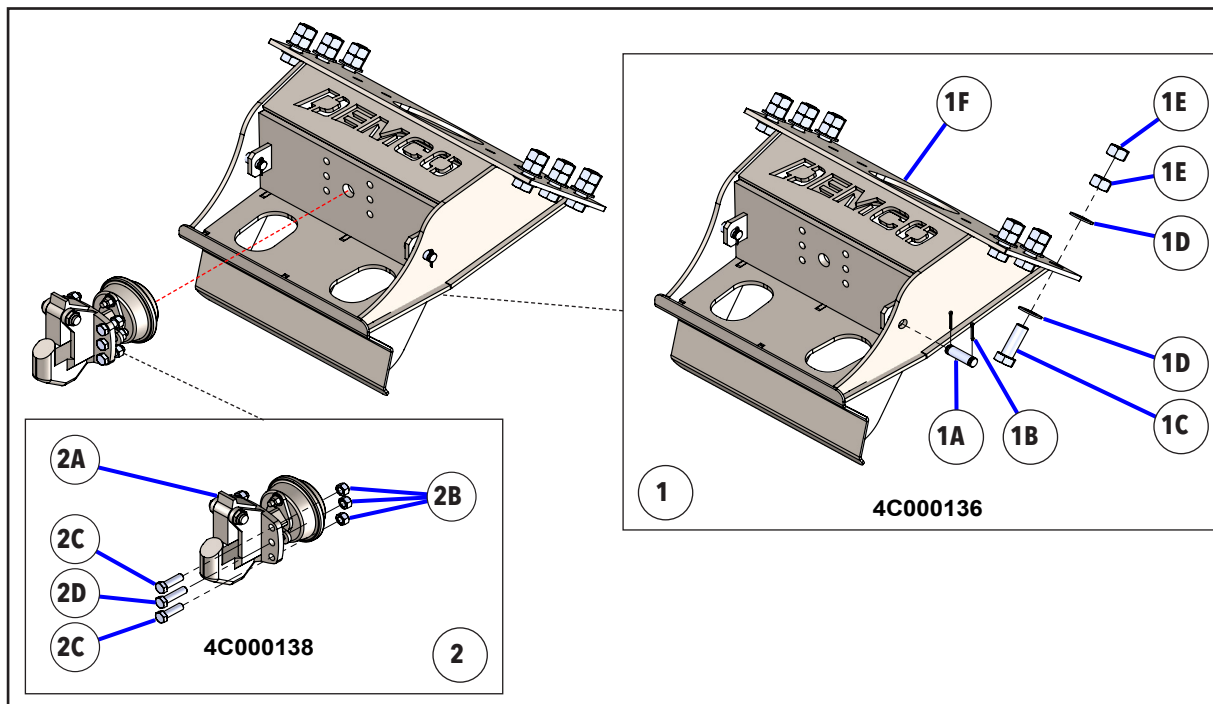

| BOM ID | Qty | Item No | Description |
|--------|-----|-------------|---|
| 1 | 1 | 4C000136 | PUSH BLOCK PINTLE HITCH COMPLETE W/ HARDWARE |
| 1A | 2 | 1AFBP3403 | PIN, CLEVIS, 1 X 2-3/4 USEABLE |
| 1B | 4 | 1AFBP3511 | PIN, COTTER, 3/16 X 1-3/4 |
| 1C | 6 | 1AFC12SDAH8 | BOLT, 1-1/4-7 X 4", GRD 8, YZ |
| 1D | 12 | 1AFBP3634 | WASHER, FLAT, 1-1/4, SAE, ZINC PLTD |
| 1E | 12 | 1AFBP3720 | NUT, HEX, 1-1/4" - 7, GRD 8, YZ |
| 1F | 1 | 5C000189 | PUSH BLOCK PINTLE HITCH |
| 2 | 1 | 4C000138 | PINTLE HOOK ASSY, COMPLETE W/ HARDWARE |
| 2A | 1 | 1ACAP3644 | PINTLE HOOK ASSY W/ AIR LOCK, PREMIER 2300A |
| 2B | 6 | 1AFBP3442 | NUT, HEX LOCK, 3/4"-10, TOP LOCK, GRD C, PLTD |
| 2C | 4 | 1AFBP3197 | HEX CAP SCREW, 3/4"-10 X 2-1/2", GRD 8, PLTD |
| 2D | 2 | 1AFBP3209 | HEX CAP SCREW, 3/4"-10 X 3, GRD 8, PLTD |

| 4C000137 (PINTLE HITCH STUB BUMPER COMPLETE) | | | |
|--|------|-------------|---|
| BOM ID | Qty | Item No | Description |
| 1 | 6 | 1AF009L000 | 3/4 USS FLAT WASHER ZINC PLTD |
| 2 | 6 | 1AFBP3139 | HEX CAP SCREW, 3/4"-10 X 2", GRD 5, ZINC PLTD |
| 3 | 6 | 1AFBP3296 | NYLON INSERT LOCKNUT, 3/4-10 UNC |
| 4 | 2.04 | 1AQAS000000 | RWR CONSPICUITY TAPE |
| 5 | 2 | 1AR00000050 | 4X4X3/16 PLASTIC TUBE CAP |
| 6 | 1 | 5C000191 | PINTLE HITCH STUB BUMPER |

***THIS STUB BUMPER IS SPECIFIC TO THE PINTLE HITCH/PUSH BLOCK COMBO**

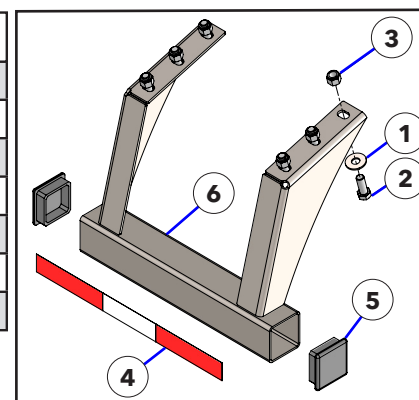

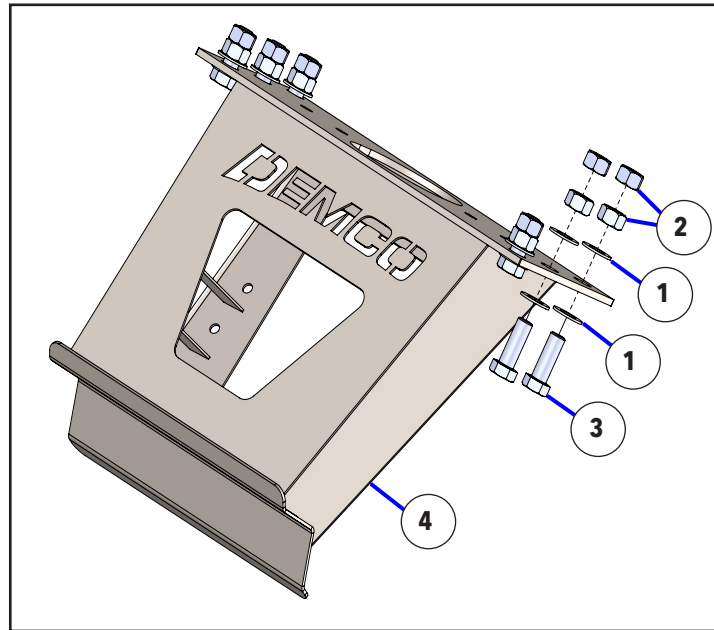

| 4C000117 (PUSH BLOCK W/ LOGO, COMPLETE W/ HARDWARE) | | | |
|--|-----|-------------|-------------------------------------|
| BOM ID | Qty | Item No | Description |
| 1 | 12 | 1AFBP3634 | WASHER, FLAT, 1-1/4, SAE, ZINC PLTD |
| 2 | 12 | 1AFBP3720 | NUT, HEX, 1-1/4"-7, GRD 8, YZ |
| 3 | 6 | 1AFC12SDAH8 | BOLT, 1-1/4-7 X 4", GRD 8, YZ |
| 4 | 1 | 5C000172 | PUSH BLOCK W/ DEMCO LOGO |

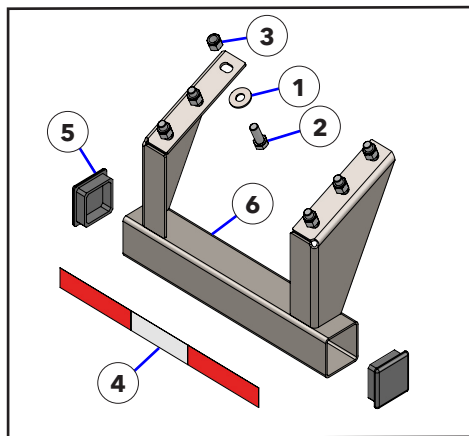

| 4C000116 (STUB BUMPER, COMPLETE W/ END CAPS & HARDWARE) | | | |
|--|------|-------------|---|
| BOM ID | Qty | Item No | Description |
| 1 | 6 | 1AF009L000 | 3/4 USS FLAT WASHER ZINC PLTD |
| 2 | 6 | 1AFBP3139 | HEX CAP SCREW, 3/4"-10 X 2", GRD 5, ZINC PLTD |
| 3 | 6 | 1AFBP3296 | NYLON INSERT LOCKNUT, 3/4-10 UNC |
| 4 | 2.04 | 1AQAS000000 | RWR CONSPICUITY TAPE |
| 5 | 2 | 1AR00000050 | 4X4X3/16 PLASTIC TUBE CAP |
| 6 | 1 | 5C000173 | PINTLE HITCH STUB BUMPER |

***THIS STUB BUMPER IS SPECIFIC TO THE PUSH BLOCK OPTION**

REAR ATTACHMENT OPTIONS

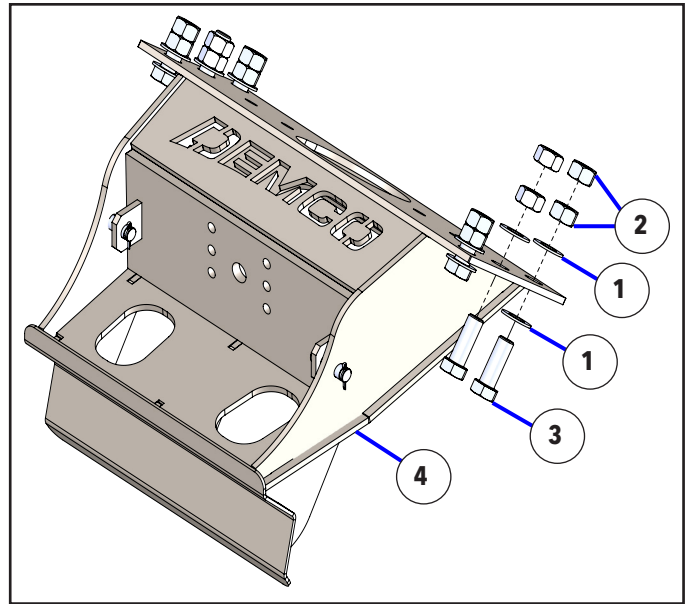
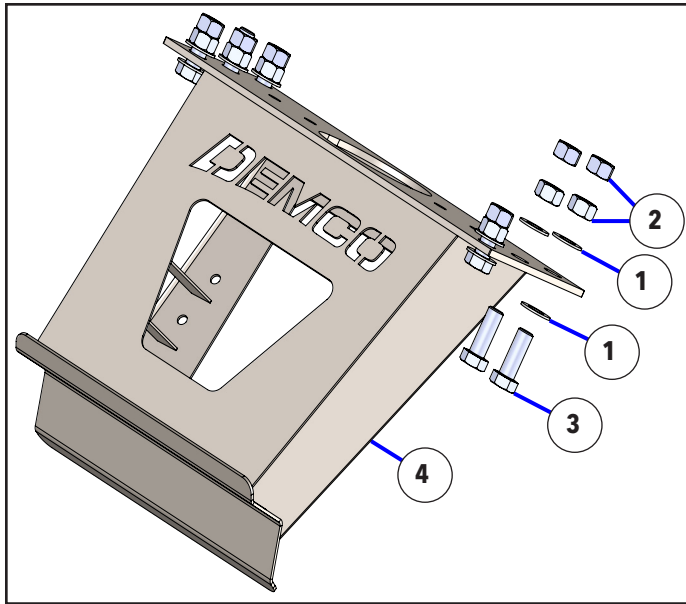

| 4C000119 (PUSH BLOCK W/ LOGO, COMPLETE FOR UR BUMPER) | | | |
|--|-----|-------------|--------------------------------|
| BOM ID | Qty | Item No | Description |
| 1 | 10 | 1AFBP3634 | WASHER, FLAT, 1-1/4, SAE, PLTD |
| 2 | 12 | 1AFBP3720 | NUT, HEX, 1-1/4"-7, GRD 8, YZ |
| 3 | 6 | 1AFC12SDAH8 | BOLT, 1-1/4-7 X 4", GRD 8, YZ |
| 4 | 1 | 5C000172 | PUSH BLOCK W/ DEMCO LOGO |

| 4C000139 (PUSH BLOCK PINTLE HITCH W/ HARDWARE, UR BUMPER) | | | |
|--|-----|-------------|-------------------------------|
| BOM ID | Qty | Item No | Description |
| 1 | 10 | 1AFBP3634 | WASHER, FLAT, 1-1/4, SAE, PLT |
| 2 | 12 | 1AFBP3720 | NUT, HEX, 1-1/4"-7, GRD 8, YZ |
| 3 | 6 | 1AFC12SDAH8 | BOLT, 1-1/4-7 X 4", GRD 8, YZ |
| 4 | 1 | 5C000189 | PUSH BLOCK W/ DEMCO LOGO |

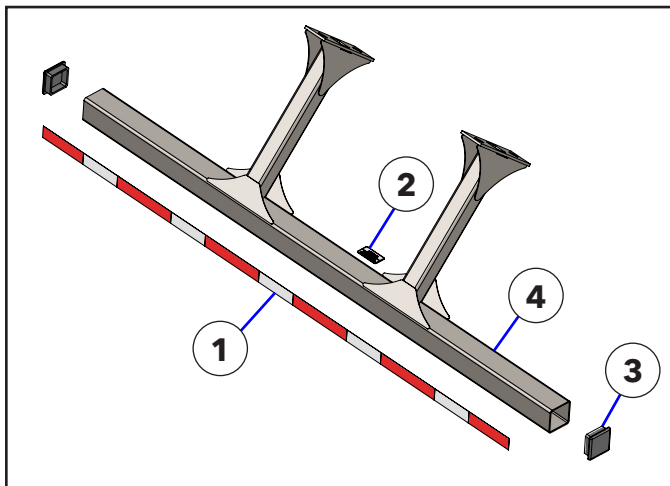

| UNDERRIDE BUMPER ONLY HARDWARE | | | |
|--------------------------------|-----|-------------|--------------------------------|
| BOM ID | Qty | Item No | Description |
| 1 | 8 | 1AFBP3634 | WASHER, FLAT, 1-1/4, SAE, PLTD |
| 2 | 8 | 1AFBP3720 | NUT, HEX, 1-1/4"-7, GRD 8, YZ |
| 3 | 4 | 1AFC12SDAH8 | BOLT, 1-1/4-7 X 4", GRD 8, YZ |

| 4C000118 (UNDERRIDE BUMPER PROTECTOR, COMPLETE W/O HARDWARE) | | | |
|---|------|-------------|---------------------------|
| BOM ID | Qty | Item No | Description |
| 1 | 7.95 | 1AQAS000000 | RWR CONSPICUITY TAPE |
| 2 | 1 | 1AQCD065061 | ICC BUMPER DECAL |
| 3 | 2 | 1AR00000050 | 4X4X3/16 PLASTIC TUBE CAP |
| 4 | 1 | 5CAM8105 | UNDERRIDE BUMPER GUARD |

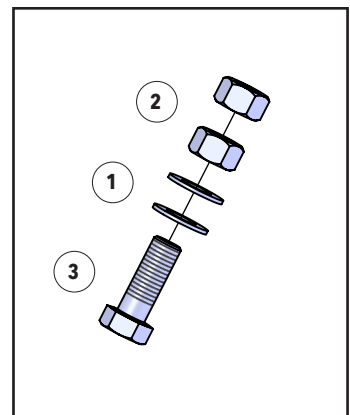

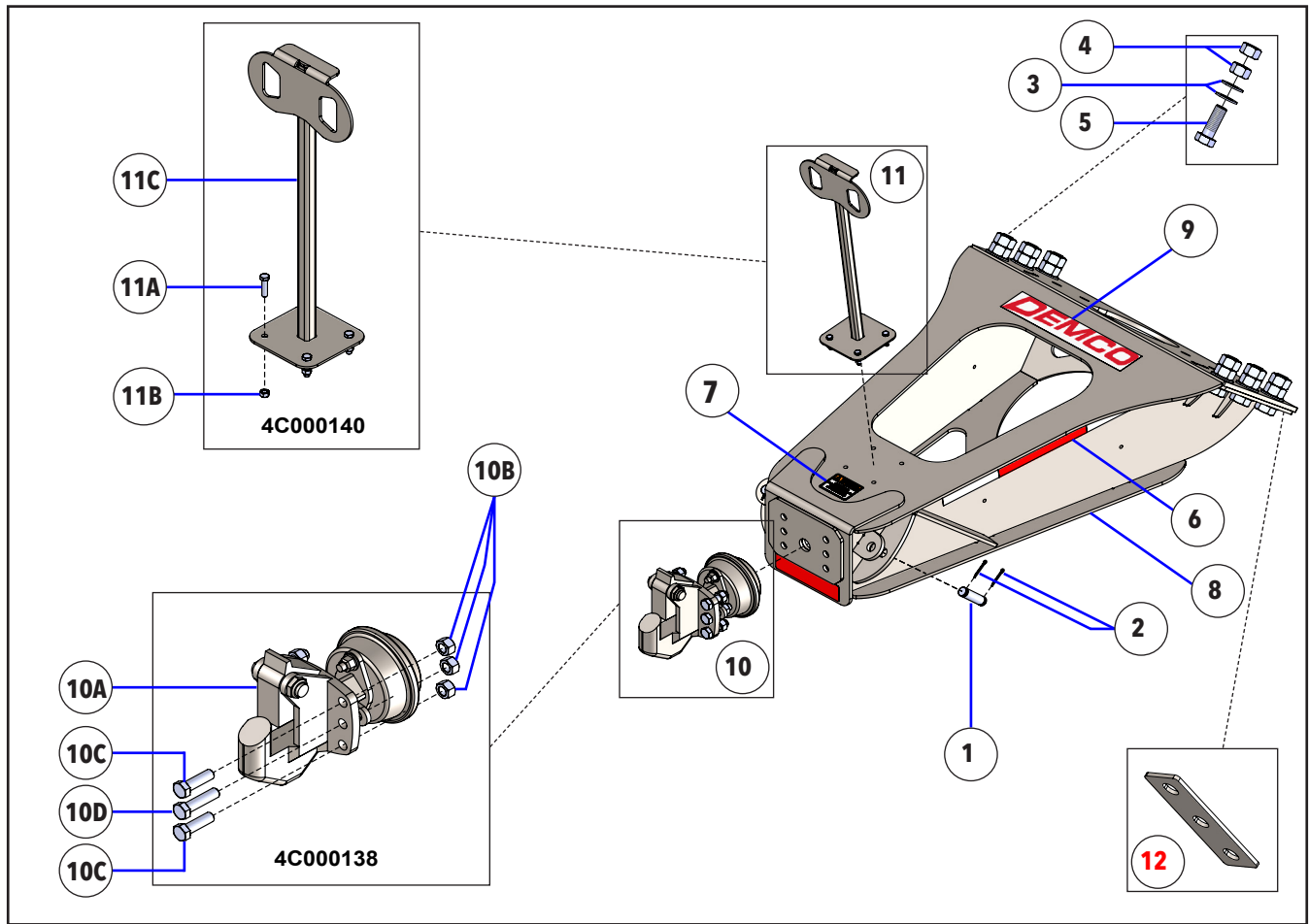

| 5C000200 (EXTENDED PINTLE HITCH ASSEMBLY) | | | |
|---|------|-------------|--|
| BOM ID | Qty | Item No | Description |
| 1 | 2 | 1AFBP3403 | PIN, CLEVIS, 1 X 2-3/4 USEABLE |
| 2 | 4 | 1AFBP3511 | PIN, COTTER, 3/16 X 1-3/4 |
| 3 | 10 | 1AFBP3634 | WASHER, FLAT, 1-1/4, SAE, PLTD |
| 4 | 12 | 1AFBP3720 | NUT, HEX, 1-1/4"-7, GRD 8, YZ |
| 5 | 6 | 1AFC12SDAH8 | BOLT, 1-1/4-7 X 4", GRD 8, YZ |
| 6 | 6.58 | 1AQAS000000 | RWR CONSPICUITY TAPE |
| 7 | 1 | 1AQWA065076 | WARNING - HITCH LOAD HAZARD |
| 8 | 1 | 5C000199 | MY24 EXTENDED PINTLE HITCH MOUNT |
| 9 | 1 | DE21005 | SMALL RED DEMCO DECAL, 17" X 3.125" |
| 10 | 1 | 4C000138 | PINTLE HOOK ASSY, COMPLETE W/ HARDWARE |
| 10A | 1 | 1ACAP3644 | PINTLE HOOK ASSY W/ AIR LOCK, PREMIER 2300A |
| 10B | 6 | 1AFBP3442 | NUT, HEX LOCK, 3/4"-10, TOP LOCK, GRD C, PLTD |
| 10C | 4 | 1AFBP3197 | HEX CAP SCREW, 3/4"-10 X 2-1/2", GRD 8, PLTD |
| 10D | 2 | 1AFBP3209 | HEX CAP SCREW, 3/4"-10 X 3, GRD 8, PLTD |
| 11 | 1 | 4C000140 | EXTENDED PINTLE HOSE HANGER COMPLETE W/ HARDWARE |
| 11A | 4 | 1AFBP3005 | HEX CAP SCREW, 3/8"-16 X 1-1/2", GRD 5, PLTD |
| 11B | 4 | 1AFC17F0000 | NUT, HEX, 3/8"-16, GRD 2, PLTD |
| 11C | 1 | 5C000192 | EXTENDED PINTLE HOSE HANGER |
| 12* | 2 | 3C000226 | MY24 EPH MOUNTING BACKING PLATE |

*NOT REQUIRED WHEN MOUNTING WITH UNDERRIDE BUMPER

REAR ATTACHMENT OPTIONS

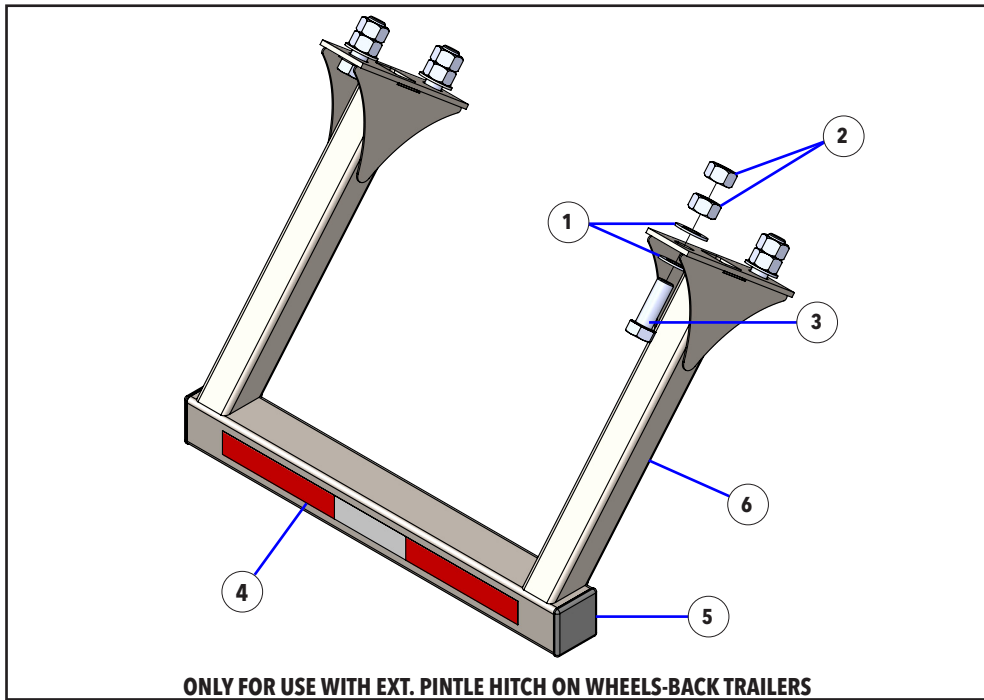

| 4C000153 (LIGHTWEIGHT BUMPER, COMPLETE FOR EXTENDED PINTLE HITCH) | | | |
|---|------|-------------|------------------------------------|
| BOM ID | Qty | Item No | Description |
| 1 | 8 | 1AFBP3634 | WASHER, FLAT, 1-1/4, SAE, PLTD |
| 2 | 8 | 1AFBP3720 | NUT, HEX, 1-1/4"-7, GRD 8, YZ |
| 3 | 4 | 1AFC12SDAH8 | BOLT, 1-1/4-7 X 4", GRD 8, YZ |
| 4 | 2.42 | 1AQAS000000 | RWR CONSPICUITY TAPE |
| 5 | 2 | 1AR00000050 | 4X4X3/16 PLASTIC TUBE CAP |
| 6 | 1 | 5C000227 | MY24 SLIM BUMPER FOR EPH, WELDMENT |

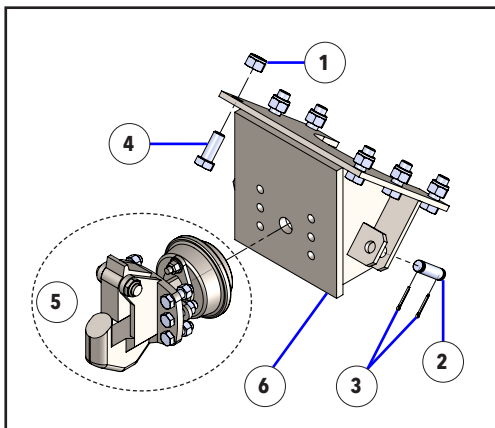

| STANDARD PINTLE HITCH MOUNT | | | |
|------------------------------------|-----|-----------|--------------------------------|
| BOM ID | Qty | Item No | Description |
| 1 | 6 | 1AFBP3295 | NUT, NYLOCK, 1"-8, GRD 8, YZ |
| 2 | 2 | 1AFBP3403 | PIN, CLEVIS, 1" X 2-3/4" L |
| 3 | 4 | 1AFBP3511 | PIN, COTTER, 3/16 X 1-3/4 |
| 4 | 6 | 1AFBP3721 | BOLT, 1"-8 X 2-1/2", GRD 8, YZ |
| 5* | 1 | 4C000138 | PINTLE HOOK ASSY, COMP. |
| 6 | 1 | 5CAM8103 | PINTLE HITCH MOUNT |

*SEE PREVIOUS PAGE FOR PARTS BREAKDOWN

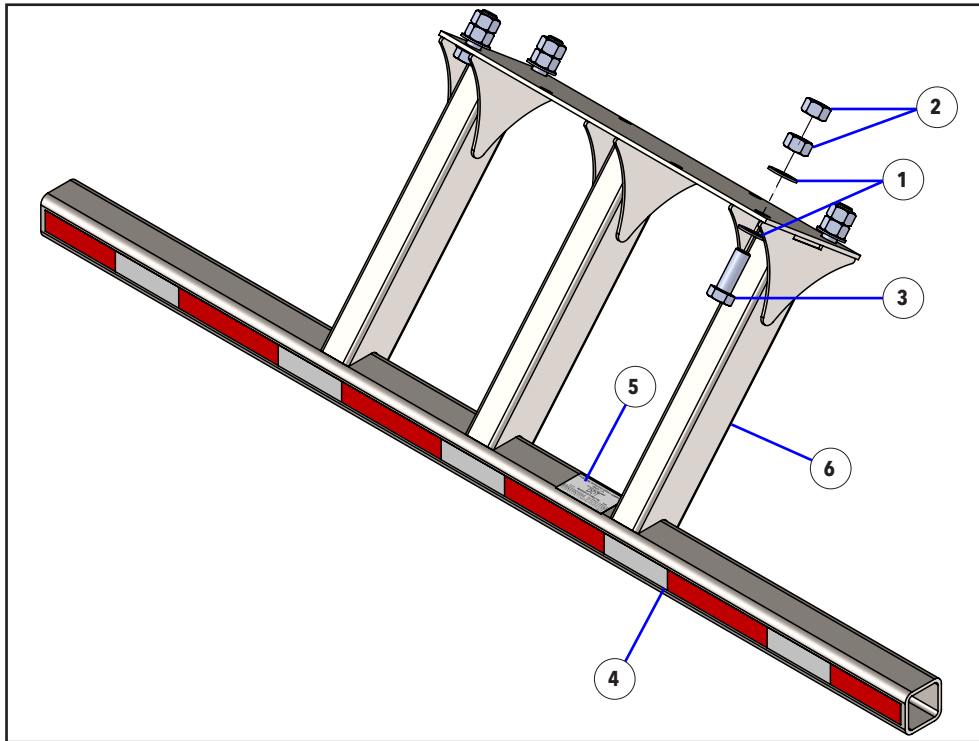

CMVSS UNDERRIDE BUMPER

| BOM ID | Qty | Item No | Description |
|--------|------|-------------|--------------------------------|
| 1 | 8 | 1AFBP3634 | WASHER, FLAT, 1-1/4, SAE, PLTD |
| 2 | 8 | 1AFBP3720 | NUT, HEX, 1-1/4"-7, GRD 8, YZ |
| 3 | 4 | 1AFC12SDAH8 | BOLT, 1-1/4-7 X 4", GRD 8, YZ |
| 4 | 7.95 | 1AQAS000000 | RWR CONSPICUITY TAPE |
| 5 | 1 | 1AQCD065061 | ICC BUMPER DECAL |
| 6 | 1 | 5CAM9343 | UNDERRIDE BUMPER GUARD, CMVSS |

PUSH BLOCK COMPATIBLE W/ CMVSS BUMPER

| BOM ID | Qty | Item No | Description |
|--------|-----|-----------|--------------------------------|
| 1 | 4 | 1AFBP3295 | NUT, NYLOCK, 1"-8, PLTD |
| 2 | 4 | 1AFBP3721 | BOLT, 1"-8 X 2-1/2", GRD 8, YZ |
| 3 | 1 | 5CAM9345 | CMVSS BUMPER PUSHBLOCK |

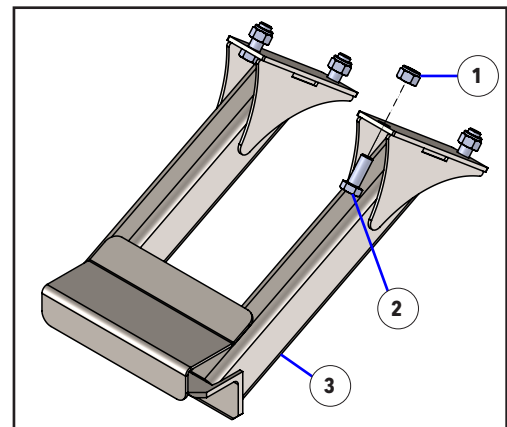

REAR STROBE LIGHT OPTION

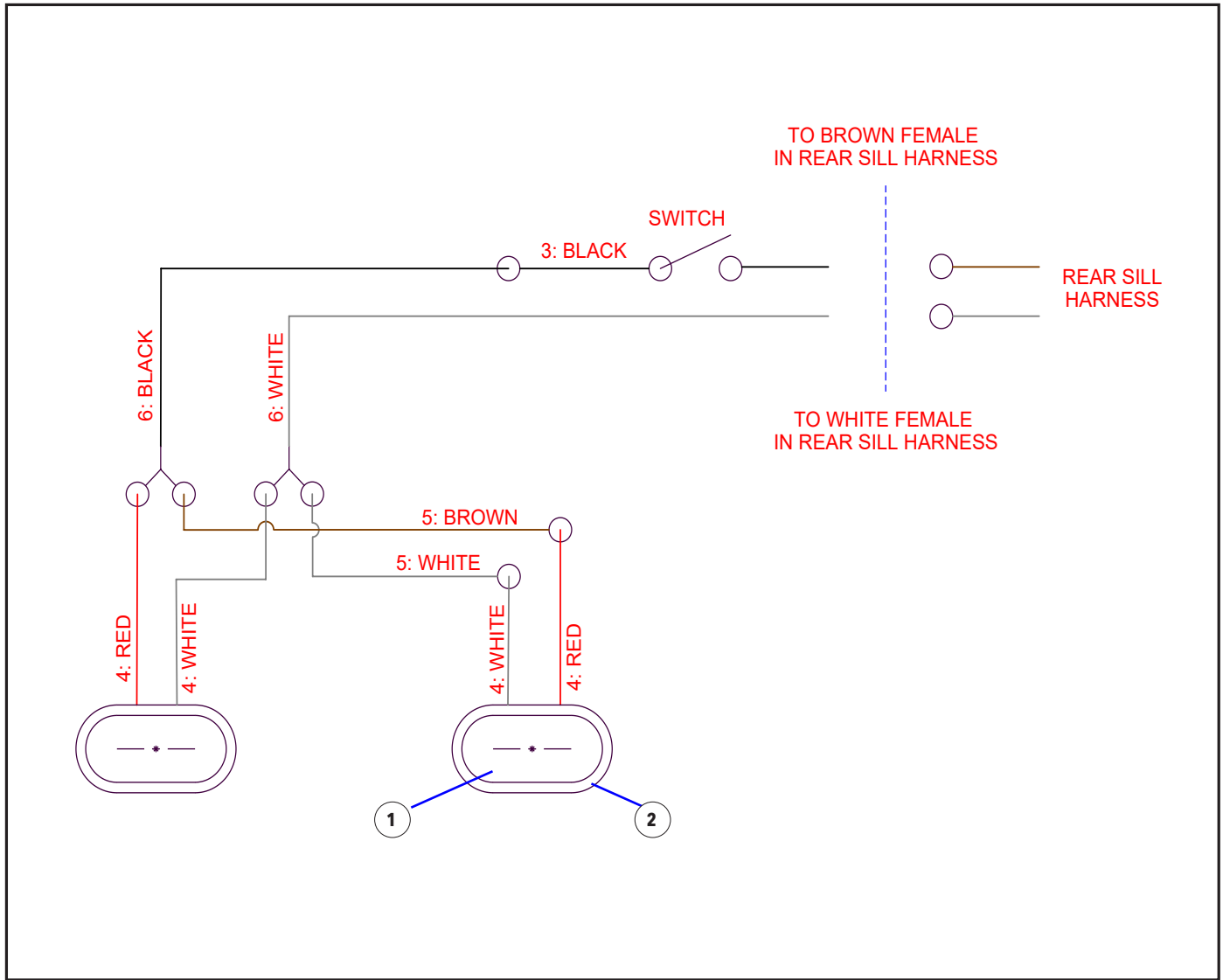

| REAR STROBE LIGHT KIT (4C000133) | | | |
|----------------------------------|-----|-------------|----------------------------------|
| BOM ID | Qty | Item No | Description |
| 1 | 2 | 1AEL060360Y | 6" OVAL AMBER STROBE LIGHT |
| 2 | 2 | 1AEL0607003 | 6" OVAL GROMMET |
| 3 | 1 | 1AES0096843 | SWITCH, SPST ON-OFF |
| 4 | 2 | 1AEX0095500 | HARN 8" STROBE LIGHT PLUG WIRE |
| 5 | 1 | 1AEX4010060 | HARN 60" M/C, 2M .180 BULLETS/2F |
| 6 | 1 | 1AEX8834236 | HARN 60" M/C, 2M .180 BULLETS/4F |

DEMCO

4010 320th St., Boyden, IA. 51234

Phone: (712) 725-2311

Fax: (712) 725-2380

Toll Free: 1-800-54DEMCO (1-800-543-3626)

**Demco warranty policies, operator manuals, and product registration
can be found online:**

www.demco-products.com