



*Doing Our Best to Provide You the Best*

8C000003, Rev A  
02/24

---

## **SIDE DUMP TRAILERS WITH TURNTABLE (All Models)**

---



# **OPERATOR MANUAL**

Product Disclaimer.....	3
Introduction.....	4
To the Dealer Checklist.....	6
To the Owner.....	7
Trailer Information.....	8
Trailer Specifications and Features.....	9
Safety.....	10
Maintenance Safety.....	14
Torque Specifications and Requirements.....	15
Tub Operating Instructions.....	17
Maintenance.....	19
Inspection and Maintenance Checklists.....	21
Electrical System.....	24
Hydraulic System.....	25
Parking Brakes.....	26
Full Function Anti-Lock Brake System.....	27
Adjustment and Operation of Brakes.....	28
Tires.....	29
Hub Pilot Wheel Installation.....	30
Wheel Maintenance During Tire Inspection.....	31
Axle Inspection.....	32
Air Suspension and Suspension Torque.....	33
General Troubleshooting.....	34

In this document you will find information based on available knowledge at the time of its publication. To be accurate with the information, every effort was made but may not cover all details or variations of a trailer or provide every possibility in connection with its production, operation and maintenance. A Feature and Option may be presented in the manual that is not relevant to this trailer. Demco assumes no obligation of notice, to holders of this document, with changes made to a product.

**SPECIFICATIONS AND DESIGN ARE SUBJECT TO CHANGE WITHOUT NOTICE.**

Demco is often making improvements and developing new designs. In doing so, we reserve the right to make changes and/or improvements without obligation for equipment sold beforehand. Self-modification to our trailers may affect the operation, function, and safety, so this is not advised. If a replacement part is necessary, Demco should supply it, please contact your nearest dealer or Demco.

**DEMCO STATEMENT OF PRODUCT SAFETY:**

As a producer of agricultural and transportation equipment, Demco is fully aware of its responsibility of providing its customers products that perform their expected use, in a truly safe manner. Safety considerations shall be a fundamental and high precedence part of all engineering/design analysis and judgments involving Demco products. It is our stated policy that our products will be manufactured to coincide with the safety standards specified by the National Association of Trailer Manufacturers and/or any other officially recognized standards at the time manufactured. However, this statement should not be translated to mean that our product will uphold against a customer's own carelessness or disregard for common safety practices specified in each product's manual, nor will we be accountable for any such occurrence.

## INTRODUCTION

At Demco we strive to design, produce and deliver the highest quality trailer on the market. Our employees have a strong background of knowledge and combined experience in manufacturing to put quality workmanship into our products. In this manual you will find information covering all models of the Demco Side Dump Trailer line. Use the table of contents to locate specific areas of interest.

### GENERAL INFORMATION

Demco requires that you and anyone else who will be operating and maintaining the trailer read and understand the guidelines in the manual for safe, efficient, and trouble free operations. Proper maintenance, adjustments and use will result in many years of service. Keep this manual handy for frequent reference and to pass on to new operators or owners. If assistance, information, or additional copies of the manual are needed, contact the nearest dealer, a distributor, or Demco.

### PLEASE NOTE

- All documents within the manual referring to products not manufactured by Demco have been printed with the permission of the manufacturer specified.
- All references to driver, passenger, front and rear of the trailer are determined from a position behind the trailer and facing forward.

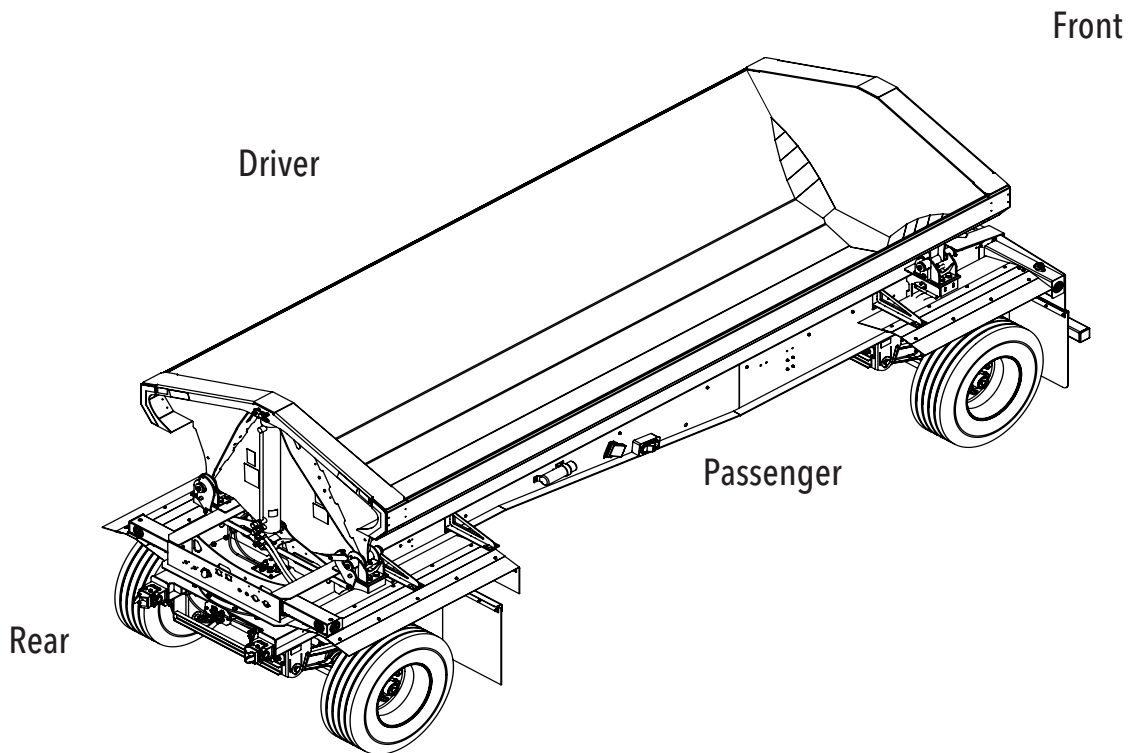

**WARRANTY POLICIES**

Please go online to review Demco Warranty Policies. The warranty information is located at [www.demco-products.com/resources/warranty-policies](http://www.demco-products.com/resources/warranty-policies).

The Demco Warranty does not cover the following:

- 1) Cleaning, transporting, mailing and service call charges.
- 2) Depreciation or damage caused by normal wear, accidents, improper protection or improper use.

**Serial Number**

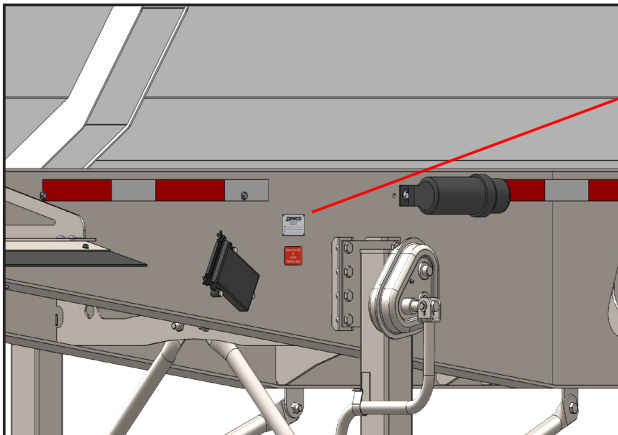

**Example: VIN Number Description**  
**57CKS4029CT627045**

Demco  
 Side Dump  
 40 Length  
 No. of Axles  
 Check Digit  
 Model Year Demco  
 Demco Identifier Number  
 Trailer Sequence

**In addition to the VIN number Demco has placed a coded unit number on the chassis and the tub. Please contact Demco at 1-800-247-6010 if you need assistance locating these numbers.**

Record your trailer model and serial number in the space provided below. You will need this to register your product warranty. Your dealer will also need this information to provide prompt, efficient service when ordering parts.

<b>MODEL NO.</b> _____
<b>SERIAL NO.</b> _____
<b>DATE PURCHASED</b> _____

**Pre-Delivery Checklist**

Inspect the trailer thoroughly after shipment to be certain it is functioning properly before delivering it to the customer. The following checklist is a reminder of points to cover. Check off each item as it is found satisfactory or after proper adjustment is made.

- 1. All hardware properly tightened
- 2. Pintle hitch and safety cables properly connected
- 3. Lubrication of grease fittings
- 4. Lug nuts are tight
- 5. All decals properly located and readable
- 6. Lights function properly
- 7. Air lines tight and no pinched lines
- 8. Brakes functioning properly
- 9. Overall condition (touch up any scratches, clean and polish)
- 10. Operator's manual included

**Date Delivered:** \_\_\_\_\_

**Signature of Salesman or Technician:** \_\_\_\_\_

**Delivery Checklist**

Review the operator's manual with the customer. Explain the following:

- 1. Safe operation and service
- 2. Correct trailer operation
- 3. Daily and periodic lubrication and maintenance
- 4. Daily and periodic inspections
- 5. Trouble shooting
- 6. Storing trailer
- 7. Demco parts and service policies
- 8. Have the customer write the trailer model and serial number in space provided in manual introduction.
- 9. Give customer the operator's manual and encourage the customer to read the manual carefully.
- 10. Customer to complete warranty registration on Demco's website.

**Date Delivered:** \_\_\_\_\_

**Signature:** \_\_\_\_\_

**Model No:** \_\_\_\_\_

**Serial No:** \_\_\_\_\_

Thank you for your recent purchase of a New Demco Side Dump Trailer. We're "Doing Our Best To Provide You The Best". However, in the event that a problem does occur, it is imperative that your warranty registration is on file so we can accurately respond to your specific circumstances. You will need the Model Number, Serial Number and Date of Purchase. (Space is provided on page 5 to record this information.)

**Register  
Warranty  
One of  
Two Ways**

**We have two easy ways to register your warranty:**

- **Call our toll free number and ask for warranty registration.  
1-888-274-6010**
- **Register on-line at:  
[www.demco-products.com/resources/product-registration](http://www.demco-products.com/resources/product-registration)**



### **Manuals and Assistance**

This manual has been prepared to assist you in the operation of your new trailer and contains information pertaining to safety and operations.

Demco personnel are available to assist you if questions arise concerning the maintenance or operations of your trailer. 1-800-54DEMCO (800-543-3626).

To order any parts or additional options for your trailer, please contact your dealer or view our online manuals at: [www.demco-products.com](http://www.demco-products.com)

- Current manuals are listed in | Semi Trailers | Side Dump Trailers | specific configuration | Manuals (at the bottom of the page)
- Older manuals are listed in | Resources | Archived Manuals

## TRAILER INFORMATION

---

**GAWR (Gross Axle Weight Rating):** The maximum gross weight that an axle can support. It is the lowest of axle, wheel, or tire rating. Usually the tire or wheel rating is lower than the axle rating and determines the GAWR. The GAWR is listed on the VIN plate.

**GVWR (Gross Vehicle Weight Rating):** The maximum allowable gross weight of the trailer and its contents. The gross weight of the trailer includes the weight of the trailer and all of the items with it. GVWR is sometimes referred to as GTWR (Gross Trailer Weight Rating) or MGTW (Maximum Gross Trailer Weight). GVWR, GTWR and MGTW are all the same rating.

The sum total of the GAWR for all trailer axles may be less than the GVWR for the trailer, because some of the trailer load is to be carried by the tow vehicle, rather than by the trailer axle(s). The total weight of the cargo and trailer must not exceed the GVWR, and the load on an axle must not exceed its GAWR. The GVWR is listed on the VIN Plate.

**VIN (Vehicle Identification Number):** Identifies the trailer in four sections. The first section of three characters identifies the manufacturer. The second section consists of five characters (VIN positions 4-8), these are the attributes of the vehicle. The third section is one character which is the check digit. The fourth section consists of eight characters (VIN positions 10-17). The first character represents the vehicle model year, the second character represents the plant of manufacture. The third through eighth characters are a sequential production number. The VIN Plate is located on the passenger side of the bulkhead at the front of the trailer.

**PSI (Pounds Per Square Inch):** The tire pressure measurement. The PSI is listed on the VIN Plate.

**Empty Weight:** Some information that comes with the trailer is not a reliable source for 'empty' weight. The shipping documents list average or standard weights and your trailer may be equipped with options. To determine the 'empty' or weight of your trailer, have trailer weighed at a commercial scale.

**Turntable Ring:** A coupling device, or bearing, that attaches the front axle subframe to the main chassis of a pup trailer, and is not readily detachable. The upper and lower rings of this device allow the main chassis to rotate about the front axle subframe.

**Trailer Lighting and Braking Connectors:** A device that connects electrical power from the tow vehicle to the trailer. If your trailer has electric brakes, the connector will also supply power to the brakes from the tow vehicle.

**Registration Holder:** Located on the driver side, under the front deck. Use this to keep the registration with the trailer at all times. The registration holder is often referred to as the "manifest" holder.



1. 20" Deep Twin "I" Beam Chassis with 3/8" Fifth Wheel Plate
2. Tub dump direction indicators visible in truck mirrors
3. Holland Atlas 51000 Landing Gear With 2 Speed Gear Box
4. Holland 23,000 lb. 5-3/4" OD Axle
5. Haldex 2S/1M ABS System
6. Six Integrated Tub Pivot Points with Greaseless Pivot Bearings.
7. Tub dump direction controlled from the left side. No need to walk all around the trailer to change dump direction.
8. Rubber "EdgeFlex" fenders with bolt-on mounts. Easily replace damaged fender parts.
9. 1/4" AR450 Tub with exclusive "Flex Corner" design. (3/16" AR450 Available)
10. Large Single "G" Rail on Tub. Lighter and Stronger than two rail systems.
11. Suspension: Holland CBX23-17 Air Ride. Rear Axle Air Lift Available
12. Wheel & Tire Options: 11R22.5 or 11R24.5 on Steel or Aluminum Rim, 385/65R22.5 on Aluminum Rim  
(Other sizes available upon request.)
13. Hydraulic System: 3000 psi rated 3/4" Hoses, Fittings, Flow Divider, and Relief Valve.
14. Trailer Mounted Electric Over Hydraulic Control Valve Available.
15. Twin 3000 psi rated 6" Cylinders
16. Standard LED lights in enclosed boxes with sealed plugs.
17. Bolt-on Push/Lift block with Under Ride Bumper conform to Federal Motor Vehicle Safety Standards.
18. Standard Colors: Black, White, Yellow, and Burgundy. Custom Colors Available.
19. Optional Roll-Rite or Aero Electric Tarp.

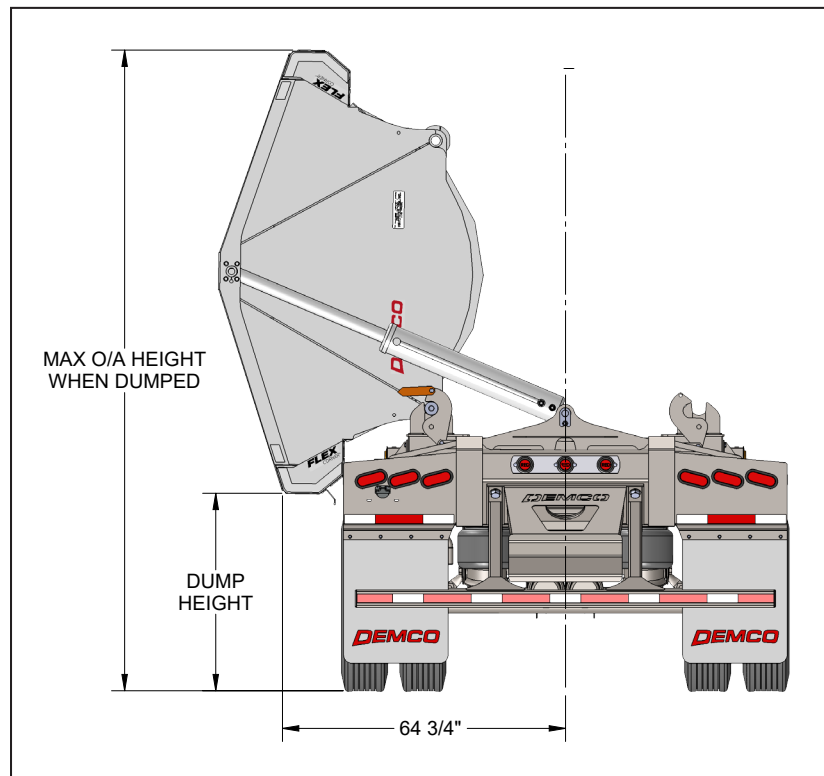



## RECOGNIZE SAFETY INFORMATION

This is the safety-alert symbol. When you see this symbol on your machine or in this manual, be alert to the potential for personal injury. Follow recommended precautions and safe operation practices.



## FOLLOW SAFETY INSTRUCTIONS

- Carefully read all safety messages in the manual and on your machine safety signs.
- Keep safety signs in good condition.
- Replace missing or damaged safety signs.
- Learn how to operate the machine and how to use controls properly.
- Do not let anyone operate without instruction.
- Keep your machine in proper working condition.
- Unauthorized modification to the machine may impair the function and/or safety and affect machine lift.



## PROTECT CHILDREN AND BYSTANDERS

- Before you back, LOOK CAREFULLY behind for children.
- Clear area of children, pets and bystanders.



## ADOPT SAFE DRIVING PRACTICES

- Always drive at a safe speed relative to local conditions and ensure that your speed is low enough for an emergency stop to be safe and secure. Keep speed to a minimum.
- Reduce speed prior to turns to avoid the risk of overturning.
- Avoid sudden uphill turns on steep slopes.
- Always keep the tractor or towing vehicle in gear to provide engine braking when going downhill. Do not coast.
- Do not drink and drive.
- Comply with state and local laws governing highway safety and movement of equipment on public roads.
- Use approved accessory lighting and necessary warning devices to protect operators of other vehicles on the highway during daylight and nighttime transport.

**HIGHWAY AND TRANSPORT OPERATIONS**

- Plan your route to avoid heavy traffic.
- Be a safe and courteous driver. Always yield to oncoming traffic in all situations, including narrow bridges, intersection, etc.
- Be observant of bridge loading ratings. Do not cross bridges rated lower than the gross weight at which you are operating.
- Always operate the tractor trailer in a position to provide maximum visibility at all times. Make allowances for increased length and weight of the equipment when making turns, stopping the unit, etc.

**AVOID HIGH PRESSURE FLUIDS**

- Escaping fluid under pressure can penetrate the skin causing serious injury.
- Avoid the hazard by relieving pressure before disconnecting hydraulic or other lines. Tighten all connections before applying pressure.
- Search for leaks with a piece of cardboard.
- Protect hands and body from high pressure fluids.
- If an accident occurs, see a doctor immediately.

**DISPOSE OF FLUIDS PROPERLY**

- Improperly disposing of fluids can harm the environment and ecology. Before draining any fluids, contact your local environmental agency for the proper waste disposal methods.
- Use proper container when draining fluids. DO NOT use food or beverage containers that may mislead someone into drinking from them.
- DO NOT pour oil into the ground, down a drain, or into a stream, pond, or lake. Observe relevant environmental protection regulations when disposing of oil and other harmful waste.





**THIS SYMBOL MEANS:  
ATTENTION!  
BECOME ALERT!  
YOUR SAFETY IS  
INVOLVED!**

**TAKE NOTE! THIS SAFETY ALERT SYMBOL FOUND THROUGHOUT THIS MANUAL IS USED TO CALL YOUR ATTENTION TO INSTRUCTIONS INVOLVING YOUR PERSONAL SAFETY AND SAFETY OF OTHERS. FAILURE TO FOLLOW THESE INSTRUCTIONS CAN RESULT IN INJURY OR DEATH!**

### **SIGNAL WORDS**

Note use of following signal words **DANGER**, **WARNING**, and **CAUTION** with safety messages. The appropriate signal word for each has been selected using the following guidelines:

**DANGER:** Indicates an imminently hazardous situation that, if not avoided, will result in death or serious injury. This signal word is to be limited to most extreme situations typically for machine components which, for functional purposes, cannot be guarded.

**WARNING:** Indicates a potentially hazardous situation that, if not avoided, could result in death or serious injury, and includes hazards that are exposed when guards are removed. It may also be used to alert against unsafe practices.

**CAUTION:** Indicates a potentially hazardous situation that, if not avoided, may result in minor or moderate injury. It may also be used to alert against unsafe practices.

### **EQUIPMENT SAFETY GUIDELINES**

Every year many accidents occur which could have been avoided by a few seconds of thought and a more careful approach to handling equipment. You, the operator, can avoid many accidents by observing the following precautions in this section. To avoid personal injury, study the following precautions and insist those working with you, or you yourself, follow them.

Operator should be a responsible adult. **DO NOT ALLOW PERSONS TO OPERATE THIS UNIT UNTIL THEY HAVE DEVELOPED A THOROUGH UNDERSTANDING OF SAFETY PRECAUTIONS AND HOW IT WORKS.**

**DO NOT** modify the trailer in anyway. Doing so may impair the function and/or safety and could affect the life of the trailer.

Never exceed the maximum capacity of the trailer. By doing so you risk damage to your Demco trailer. If it's ability to do a job, or to do so safely is in question **DON'T TRY IT.**

Review safety instructions with all users annually.

Replace any caution, warning, danger or instruction safety decal that is not readable or is missing. Location of such decals is indicated in this booklet.

Do not paint over, remove, or deface any safety signs or warning decals on your equipment. Observe all safety signs and practice instructions on them.



### **LOAD DISTRIBUTION SAFETY**

The total weight of the load you put on the trailer, plus the empty weight of the trailer itself, must not exceed the trailer's Gross Vehicle Weight Rating (GVWR). You must distribute the load on the trailer such that the load on any tire or axle does not exceed the tire load rating or the Gross Axle Weight Rating (GAWR). If you do not know the weight of your trailer you must weigh it at a commercial scale. See your VIN Plate for proper ratings. Not following these guidelines could cause serious injury or even death.



### **TIRE AND LUG NUT SAFETY**

It is essential to inspect the trailer tires and wheels before each tow. Trailer tires are more likely to fail compared to car tires due to the heavier load the trailer carries. Please follow the list of guidelines and/or possibilities below that could cause serious injury or even death.

- Replace the tire before towing if the tire has a bald spot, cut, bulge, is showing any cords, or is cracked.
- If uneven tread is noticed, take the trailer to a dealer service center for an inspection. Tire imbalance, axle misalignment, or incorrect inflation could cause the uneven tread.
- Too little of tread will not be adequate enough for traction and can cause loss of control on wet highways.
- Tire pressure that is improper causes an unstable trailer and could blowout the tire causing loss of control.
- Check the tire pressure before towing, while the tire is cold. For the recommended PSI, see the VIN Plate or the side wall of the tire.
- Always order and install tires and wheels with appropriate type and load capacity to meet or exceed gross weight of unit.

The inspection of the tire and wheel lug nuts is necessary since they are prone to loosen after first being assembled. Please follow the list of guidelines and/or possibilities below that could cause serious injury or even death.

- When towing a new trailer, check the lug nuts after the first 50 to 100 miles of driving.
- Metal creep between the wheel and the lug nuts will cause wheel to loosen and could come off. Check to make sure the lug nuts are tight before each tow.
- Improper torque could cause the wheel to separate from trailer. A torque wrench should be used to tighten the lugs nuts. If one is not available use a lug wrench then take to a trailer dealer or service garage to tighten them to the required torque.

## Working on Hydraulic Systems

**⚠ DANGER:** Clear area around trailer of bystanders before raising tub.

**⚠ DANGER:** Do not perform maintenance on tub body without physically blocking body and cylinders to prevent lowering.

**⚠ DANGER**

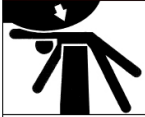

To prevent serious injury or death:  
 • Before performing maintenance between the frame rails, the trailer should be hooked to tractor on a level surface, fully dumped, then hydraulic hoses uncoupled.  
 • If service requires the tub to be partially dumped refer to owner's manual for proper safety procedures. 12-1003

Before performing maintenance between the frame rails, the trailer should be hooked to tractor on a level surface, fully dumped, then hydraulic hoses uncoupled.

If service requires the tub to be partially dumped follow the proper safety procedures.

1. Make two tub braces using 1/4" x 3" x 3" angle iron.
2. Raise tub and insert angle iron over cylinder rod on each end. (See Photo)
3. After tub is secured in raised position:
  - a. Disengage the PTO; relieve the pressure from the hydraulic system by jogging control valve both directions to relieve pressure from the system.
  - b. When working on hydraulic systems, **EXTREME** caution must be used to avoid injuries from high pressure or hot oil.
  - c. Never attempt to work on loaded trailer.

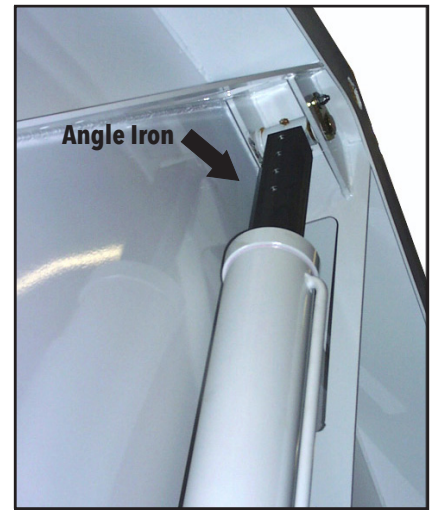

1/4" x 3" x 3" Angle Iron  
(20" Min. Length)

**WARNING:** Hydraulic fluid escaping under pressure can have enough force to penetrate the skin. Hydraulic fluid may also infect a minor cut or opening in the skin. If injured by escaping fluid, see doctor at once. Serious infection or reaction can result if medical treatment is not given immediately. Make sure all connections are tight and that hoses and lines are in good condition before applying pressure to the system. Relieve all pressure before disconnecting the lines or performing other work on the hydraulic systems.

## Tub and Frame Inspections

An important phase of trailer upkeep and maintenance is the inspection and repair, if any, of all structural steel members of the trailer frame and tub. It is readily apparent that the frame and tub must be one solid unit to carry the load safely and quickly without danger of accident or further damage to the trailer. This also prevents subsequent major repair, cost and trailer down time.

The need for a complete frame and tub inspection stems from various reasons:

- Trailer loaded to maximum rated capacity, or greater.
- Rough handling may also cause structural failures of varying degrees. The failures are the results of metal fatigue due to flexing, twisting, distortion.

Frame and tub failure will show up in the steel frame members as weld cracks, cracked and loosened steel sections.

To detect any fractures before they become major failures:

- Once a month thoroughly inspect the trailer for any sign of failure and correct any defects.
- It is desirable to have the trailer completely washed down so all the joints and welds may be closely viewed.

Tighten all bolts to torques specified in chart unless otherwise noted. Check tightness of bolts periodically, using bolt chart as guide. Replace hardware with same grade bolt.

**NOTE:** Unless otherwise specified, high-strength Grade 5 hex bolts are used throughout assembly of equipment.



**Torque Specifications**

Bolt Torque for Standard Bolts *						
"A"	GRADE 2		GRADE 5		GRADE 8	
	lb-ft	(N.m)	lb-ft	(N.m)	lb-ft	(N.m)
1/4"	6	(8)	9	(12)	12	(16)
5/16"	10	(13)	18	(25)	25	(35)
3/8"	20	(27)	30	(40)	45	(60)
7/16"	30	(40)	50	(70)	80	(110)
1/2"	45	(60)	75	(100)	115	(155)
9/16"	70	(95)	115	(155)	165	(220)
5/8"	95	(130)	150	(200)	225	(300)
3/4"	165	(225)	290	(390)	400	(540)
7/8"	170	(230)	420	(570)	650	(880)
1"	225	(300)	630	(850)	970	(1310)

Bolt Torque for Metric Bolts *						
"A"	CLASS 8.8		CLASS 9.8		CLASS 10.9	
	lb-ft	(N.m)	lb-ft	(N.m)	lb-ft	(N.m)
6	9	(13)	10	(14)	13	(17)
7	15	(21)	18	(24)	21	(29)
8	23	(31)	25	(34)	31	(42)
10	45	(61)	50	(68)	61	(83)
12	78	(106)	88	(118)	106	(144)
14	125	(169)	140	(189)	170	(230)
16	194	(263)	216	(293)	263	(357)
18	268	(363)	--	--	364	(493)
20	378	(513)	--	--	515	(689)
22	516	(699)	--	--	702	(952)
24	654	(886)	--	--	890	(1206)

Torque figures indicated are valid for non-greased or non-oiled threads and heads unless otherwise specified. Therefore, do not grease or oil bolts or cap screws unless otherwise specified in this manual. When using locking elements, increase torque values by 5%.

\* GRADE or CLASS value for bolts and cap screws are identified by their head markings.

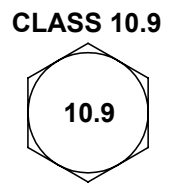
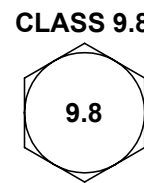
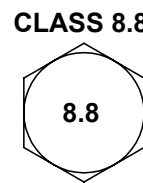
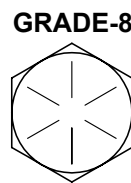
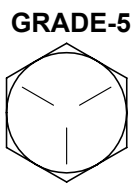
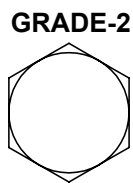
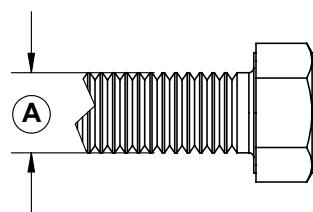

## TORQUE REQUIREMENTS

It is extremely important to apply and maintain proper wheel mounting torque on your trailer axle. Torque is a measure of the amount of tightening applied to a fastener (nut or bolt) and is expressed as length times force. For example, a force of 90 pounds applied at the end of a wrench one foot long will yield 90 lbs-ft of torque. Torque wrenches are the best method to assure the proper amount of torque is being applied to a fastener.

**NOTE:** Wheel nuts or bolts must be applied and maintained at the proper torque levels to prevent loose wheels, broken studs, and possible dangerous separation of wheel from your axle.

Be sure to use only the fasteners matched to the cone angle of your wheel (usually 60 degrees or 90 degrees). The proper procedure for attaching your wheels is as follows:

1. Start all bolts or nuts by hand to prevent cross threading.
2. Tighten bolts or nuts in the following sequence.
3. The tightening of the fasteners should be done in stages. Following the recommended sequence, tighten fasteners per wheel torque requirements diagram:

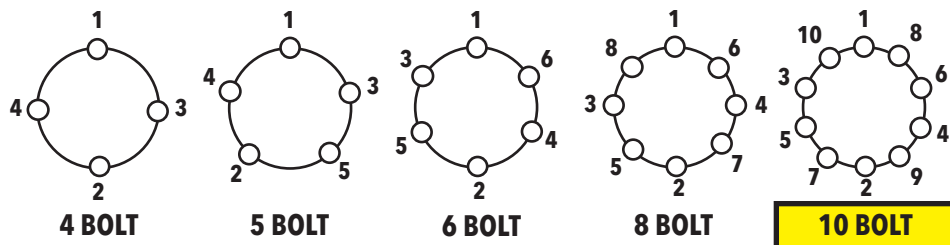

4. Wheel nuts or bolts should be torqued before first road use and after each wheel removal. Check and re-torque after the first 50 miles and again at 100 miles. Check periodically thereafter.

## WHEEL AND RIM TORQUE REQUIREMENTS

Description	Application	Minimum Torque	Maximum Torque
		(lbs-ft)	(lbs-ft)
1/2" Cone Nut	12" - 13" Wheel	50	65
	14" - 15" Wheel	90	120
5/8" Cone Nut	Flat Disc Wheel	175	225
3/4" Hex Nut	Demountable	210	260
	Ring Clamp		
3/4" Spherical Nut	Single Wheel	450	500
	Inner Dual	450	500
1-1/2" Spherical Nut	Outer Dual	450	500
5/8" Flange Nut	Wheels	275	325



**Setting the Tub to Dump Curb-Side or Road-Side**

**CAUTION:** Make sure the latches on each end of the tub are locked in the same direction. Failure to do so will result in damage to the side dump and/or tractor.

Latch Indicator Flag indicates direction of dump as shown below.

**Latch Indicator Flag Open**

**Curb-Side Dump**

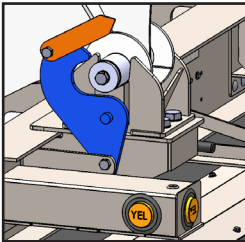

**Latch Indicator Flag Closed**

**Road-Side Dump**

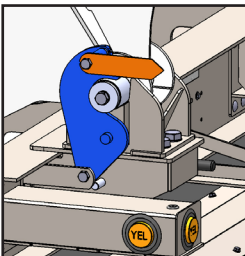

Before dumping the tub determine which direction the tub is going to dump when raised.

**All steps are performed on the driver's side only.**

**NOTE:** The following steps must be performed on both the front and the rear pivots.

**Step One:** Pull latch out to release pivot lock handle.

**Step Two**

**Step Two:** Pull bolt handle towards pivot pin to lock the tub in the left-hand (road-side) dump position.

Push bolt handle away from pivot pin to lock tub in the right-hand (curb-side) dump position.

Return latch to the locked position.

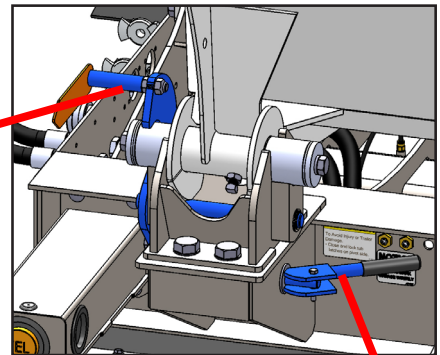
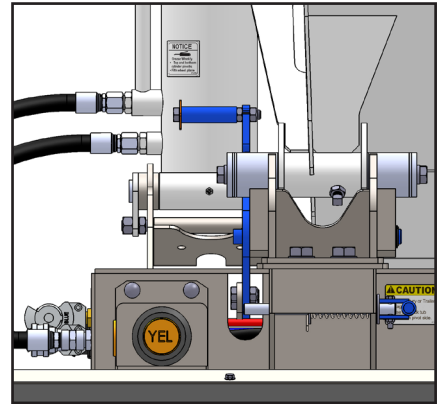

**Step One**

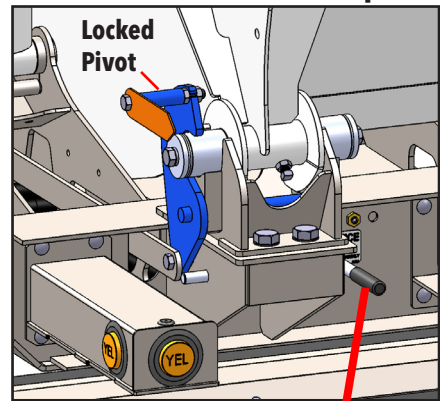

**Locked Position**

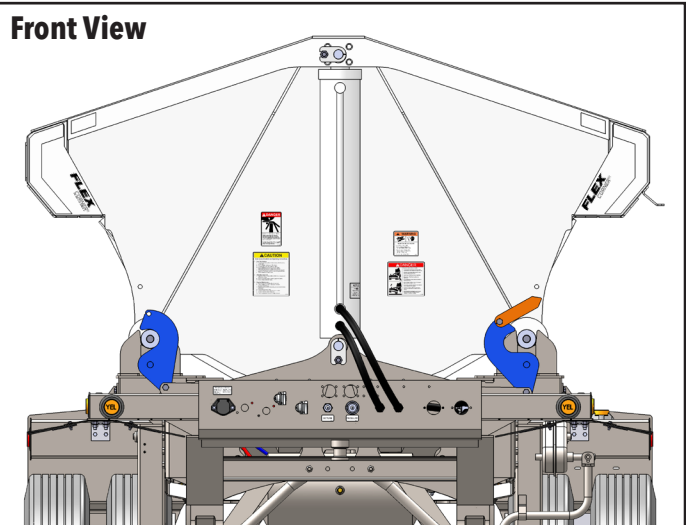

**Front View**

**Locked Position for Curb-Side Dumping**

## First Time Hookup and Charging Cylinders

**⚠ DANGER:** Clear area around trailer of bystanders before charging system.



Tilt tub part way several times to fill hydraulic cylinders before extending cylinders completely. Extend and retract cylinders completely. Check for proper operation.

## Filling and Dumping Trailer

**⚠ DANGER:** Clear area around trailer of bystanders before filling and dumping trailer.



**NOTE:** When Filling or Dumping loads, remain at the controls and stand clear of the trailer. The tub should dump in 20 seconds or less. DO NOT stop cylinder extension in middle of cycle, equipment may upset. DO NOT attempt to dump load on uneven or unstable ground.

Tub Size	Level Full - Cubic Yards	Heaped Full - Cubic Yards
20'	13.2	17.3
24'	15.8	20.8

**Lubrication  
Maintenance**

- Grease upper and lower pivot point zerks of both lift cylinders weekly. (Front lift cylinder zerks shown)

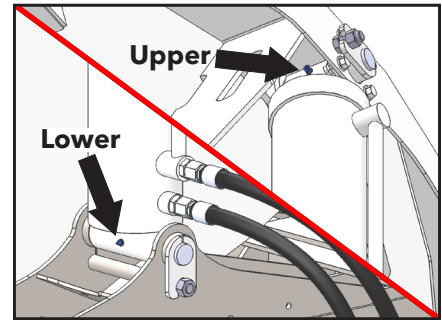

- If equipped with the remote grease zerk option, front lift cylinder zerks can be found near the curb-side front pivot. The rear lift cylinder zerks can be found near the road-side rear pivot. (Front lift cylinder zerks shown)

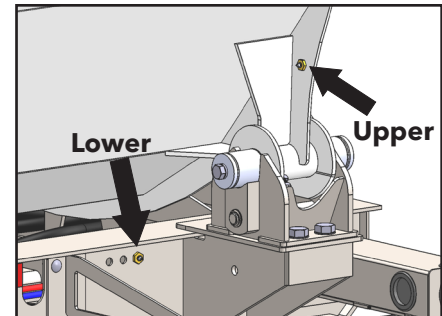

- Grease fifth wheel zerks weekly.

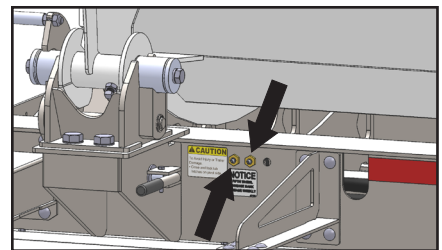

- Grease slack adjuster pivot on all wheels monthly.

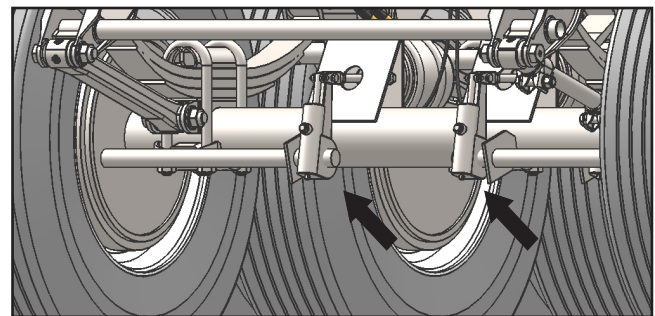

**Inspect Hydraulic  
and Air Lines Daily**

- Inspect hydraulic lines, air lines, and valves for leaks, rubbing, or crimped lines.

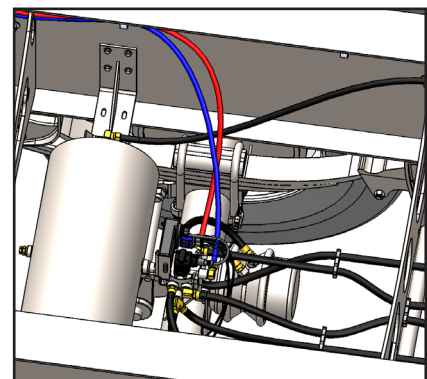

## Inspect Lights Daily

- Turn on truck lights and 4-way flashers.
- Walk around tractor and trailer to inspect that all lights are operating.

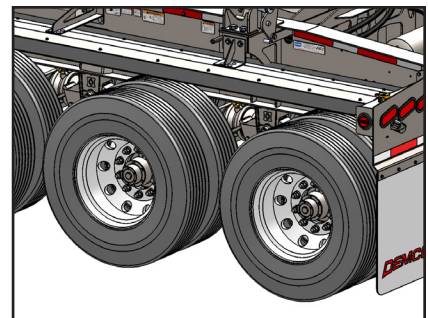
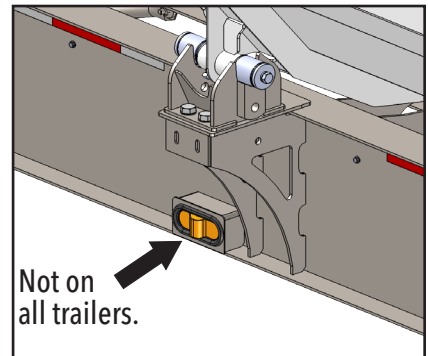
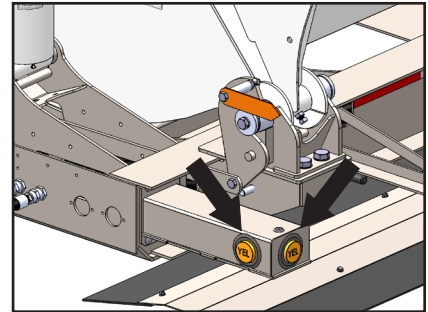
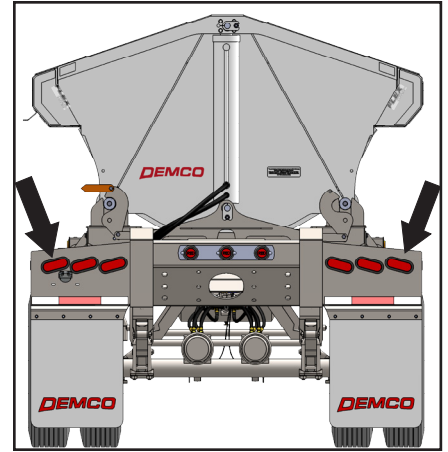

## Inspect Tires and Lug Nuts Daily

- Check Tire pressure. If necessary, inflate tires to pressure recommended by the tire manufacturer. Maximum tire pressures are molded into the tire sidewall.
- Check all hubs for loose lug nuts.
- Re-torque all wheel lugs nuts. Recommended torque dry: 450-500 ft. lbs. See sequence below.
- Check all hubs for proper oil level.
- Check all valve stems for proper mounting.
- Check that tires and rims do not rub.
- Tighten flange nuts to recommended torque using sequence shown.

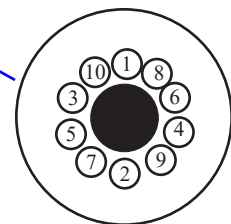

**Break-in Procedure Checklist**

**After the first twenty-four (24) hours of use, perform the following maintenance procedures:**

1. Re-torque all suspension bolts and axle u-bolts. Torque specifications (as shown on the previous page) are also on a decal located on the trailer sub-frame above the suspension.
2. Re-torque all wheel lug nuts.
3. Check all clearance lights, turn signal indicators, and stop lights.
4. Inspect all brake hoses and airlines for kinks and leaks.
5. Check hub oilers for leaks or low levels.
6. Check pintle hitch and/or push block mounting bolts for proper torque. (380 ft. lbs. dry)
7. Check turntable ring bolts for proper torque.
8. Inspect hydraulic lines and valves for leaks, chaffing or crimped lines.

**Pre-Trip Checklist**

**Perform the Pre-Trip checklist whenever the tractor-trailer has been left unattended.**

1. Check that the tongue is properly coupled to pintle hitch along with the safety cables.
2. Check that air hoses are securely attached to the trailer gladhands.
3. Check that electrical cord is properly connected to the trailer plug.
4. Walk around trailer to check conditions of tires, lights, and landing gear.
5. Check tub dump latches to ensure they are both set for dumping to the same side.

**Daily Inspection Checklist**

**Perform the Daily Inspection Checklist each day before operating your side dump trailer.**

1. Perform the Pre-Trip Checklist.
2. Inspect air and hydraulic lines for leaks, crimps, and abrasions.
3. Visually inspect tires for damage. Check tire air pressure.
4. Check hubs for loose lug nuts. Check hub caps for damage.
5. Check hub oil level and refill as needed.
6. Check trailer chassis and tub for loose fasteners of damaged parts.
7. Turn on lights and flashers. Walk around trailer to check that all lights are working. Replace any lights that are not working.

**Weekly Inspection Checklist**

**Perform the Weekly Inspection Checklist at the beginning of each week or if the trailer has not been used for more than a week.**

1. Perform the Pre-Trip and Daily Inspection Checklists.
2. Grease the top and bottom cylinder pins on the front and rear cylinders.
3. Grease the turntable ring using the six grease zerks located around the ring.

**Every 2,000 Miles or Monthly**

**Perform the following Checks Every 2,000 Miles or Monthly - Whichever Comes First**

### **AIR BRAKE SYSTEM**

1. Check air brake hose and Synflex lines for chaffing and crimping.

### **TIRES**

1. Check for signs of uneven tire wear.
2. Check tires for cuts, side wall breaks, tread cracking, or separation or feathered wear.
3. Check duals for uneven wear, and rotate if necessary.

### **BRAKE DRUMS AND WHEELS**

1. Check and determine how much brake lining has worn.
2. Inspect closely for worn stud holes, loose cap nuts and/or clamp nuts.
3. Inspect wheel, rims, and hubs for cracks, breaks or other damage.
4. Grease slack adjusters.

### **SUSPENSION ASSEMBLIES**

1. Inspect rubber bushings.
2. Inspect mounting brackets for damage or broken parts.
3. Make certain lock nuts on alignment adjusting screws are tight.
4. Check and re-torque all suspension bolts and pushblock bolts.

### **HYDRAULIC SYSTEM**

1. Check hydraulic hoses for chaffing, crimping and fasten securely.
2. Check for hydraulic leaks.
3. Make sure valves are not leaking and are operating properly.
4. Hydraulic system is entirely dependent upon towing vehicle for its supply and control. Therefore, you must maintain hydraulic system on tow vehicle. Tow vehicle should maintain 30 GPM, oil flow at 2500 PSI.

**Every 25,000 Miles  
or Annually****Perform the following Checks Every 25,000 Miles or Annually -  
Whichever Comes First****AIR BRAKE SYSTEM**

1. Inspect the brake linings and reline if necessary.
2. Check the brake drum for distortion, heat checking, out of roundness and/or scoring.
3. Remove the brake shoes to examine bushings and anchor pins.
4. Examine the brake cam, brake cam rollers and/or brake shoe wear plate for wear.

**Every 50,000 Miles  
or Annually****Perform the following Checks Every 50,000 Miles or Annually -  
Whichever Comes First****AIR BRAKE SYSTEM**

1. Inspect the brake chambers. Replace if damaged.



**CAUTION:** WE DO NOT RECOMMEND DISASSEMBLING SPRING BRAKE CHAMBERS. REPLACE THE ENTIRE SPRING BREAK.

2. Check slack adjuster bushing and brake chamber yoke pin for wear.



**CAUTION:** BE CERTAIN THE PRECEDING CHECKLIST INSPECTIONS HAVE BEEN PERFORMED.

**AIR PRESSURE BRAKE SYSTEM**

The air system of a trailer is entirely dependent upon the air brake system of the towing vehicle for its air supply and control. Therefore, the air brake system of the towing vehicle must be in good condition, or it will be impossible to obtain good brake performance on the trailer.

**HYDRAULIC PRESSURE SYSTEM**

The hydraulic systems of these trailers are entirely dependent upon the hydraulic system of the towing vehicle for its oil supply, pressure and control. Therefore, the hydraulic pressure system of the towing vehicle must be in good condition, with steady clean oil supply for proper dumping performance on the trailer.

**NOTE:** Perform this air brake system maintenance on a minimum schedule, whether on the mile or calendar basis, whichever comes first.

**NOTE:** Clean the hydraulic system at least once per year.

## Lights and Wiring

The lights and wiring system on every Demco Side Dump trailer meet or exceed all federal and state requirements in effect at the time of manufacture. Wherever required by law, lights and reflectors are marked by the manufacturer to indicate the appropriate specifications with which each complies.

For optimum performance and long life from the trailer's lights and wiring, follow this inspection procedure:

1. Clean all reflectors and lights. See that all lights burn properly. Replace all burned out lights and broken reflectors. Factory approved replacement parts should be used, and replacement bulbs of equal candle power should be used for safety.

**⚠ WARNING!** Use only a 12 volt DC battery for checking lights or anti-lock systems. Never use battery chargers or transformers.

2. Inspect all wiring to see that it is not frayed, and that it is properly supported and protected, with all connections tight. See that the light cable is clean and long enough to permit jackknife parking. Be certain that the cable is supported so that it cannot be pinched or entangled by the lower and upper couplers. Keep the 7-way plug on the light cable and the 7-way connector on the trailer free of corrosion.
3. Never replace fuses or breakers with metal foil or other devices.
4. A decal is located near the 7-way connector. You may trace individual electrical circuits by the wire colors indicated. Refer to the schematic drawing and the decal for conductor number and wire colors.

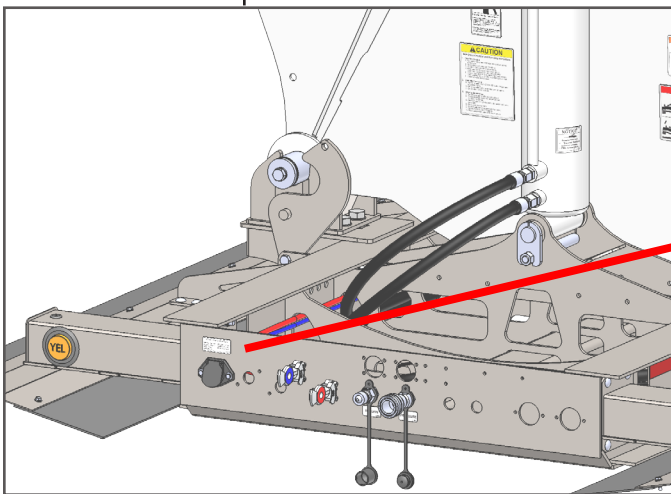

### Wiring Harness Color Code

WHITE - Ground	YELLOW - Lt Turn
BLACK - Marker	GREEN - Rt Turn
RED - Stop	BLUE - Auxiliary
BROWN - Tail	

AP 3674

**1AQAP3674**  
**WIRING HARNESS COLOR CODE DECAL**



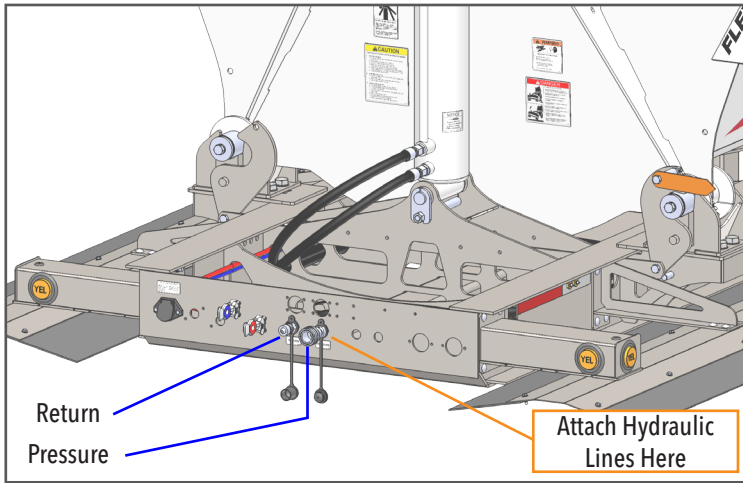

**WARNING:** Hydraulic fluid escaping under pressure can have enough force to penetrate the skin. Hydraulic fluid may also infect a minor cut or opening in the skin. If injured by escaping fluid, see doctor at once. Serious infection or reaction can result if medical treatment is not given immediately. Make sure all connections are tight and that hoses and lines are in good condition before applying pressure to the system. Relieve all pressure before disconnecting the lines or performing other work on the hydraulic systems.

**Truck-Tractor Hydraulic Systems**

Efficient, safe operation of side dump trailers require that the tractor hydraulic system provide a clean, high pressure, high volume oil supply. The hydraulic pump pressure should be set at 2500 PSI with a minimum output of 25 GPM supply and a minimum 15 gallon filtered and strained reservoir.

**NOTE:**

Hydraulic Oil Filter should be Changed every 25,000 miles or yearly, which ever comes first and hydraulic system flushed every 50,000 miles with pressure and flow rates checked.

**Generic Tractor Hydraulic System**

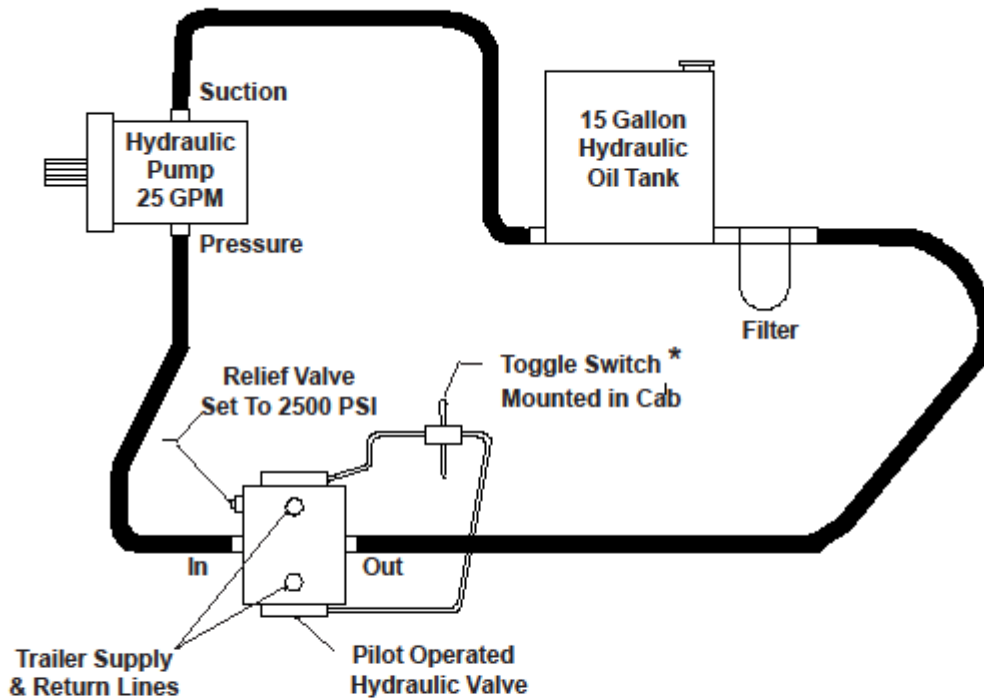



**CAUTION:** The spring brake chamber plug must remain in place when not being serviced. Chamber plugs prevent contaminants from entering brake chambers.

**NOTE:** For additional instructions on how to release makes of spring brakes, refer to the specific manufacturer's instructions.

All axles, except converter dolly axles, are equipped with spring brake chambers. Each spring brake chamber is separated into two units.

The front unit operates the service brakes. The rear unit contains a high loading capability spring that must be pressurized by air within the chamber to compress the spring to release the spring brake portion of the chamber. Loss of air pressure to the brake chamber will automatically apply the spring brake portion of the chamber for parking and/or emergency braking.

In the case of a service brake system air failure, when the spring brakes are applied in an emergency stop, a spring brake air reservoir retains enough stored air to release the spring brakes at least once by means of the tractor parking brake control.

In the absence of air pressure, a manual release is provided to allow release of the spring brake. Here's how to release spring brakes, which are standard on most Demco Side Dump trailers.

1. Always install wheel chocks at both front and rear of tires before manually releasing spring brakes.
2. An emergency parking brake release tool is stored in a pocket on the side of the brake chamber.
3. Insert the detachable release bolt through hole in head and through the piston. Turn the release bolt clockwise until it stops and locks, then pull the release bolt out as far as possible, and run the nut down, holding the bolt in place. Using a hand wrench, turn the release bolt nut clockwise until the bolt extends about three inches. Make sure the release bolt is locked properly in the piston.
4. The parking brake is now caged.

**WARNING:**

DO NOT operate your trailer with parking brakes caged or in any other way disabled. Never attempt to open a spring brake chamber. The internal spring is very dangerous.

This trailer is equipped with a Haldex Full Function Anti-Lock Brake System (FFABS) to maintain stability and control during braking by preventing wheel lock-up. FFABS consists of Sensors and Exciters, Modulating Relay Valve, and an Electronic Control Unit (ECU) to maximize the braking ability of the trailer. The ECU monitors wheel speeds, and thus vehicle speed, through the use of sensors and exciters that are mounted on the hubs of the trailer. When the ECU detects the speed of a wheel or wheels decreasing rapidly during a braking application, it releases the air pressure in the brake chamber of the affected wheel (s) via the modulator. This allows the wheel(s) to begin rotating again, thus avoiding lock-up. As soon as the wheels begin to rotate again, the ECU reapplies pressure in the affected brake chambers to maximize braking effectiveness. If the condition that caused the lock up remains, the cycle is repeated until either the brake application or vehicle is stopped. Operation is totally automatic and can occur up to six times per second.

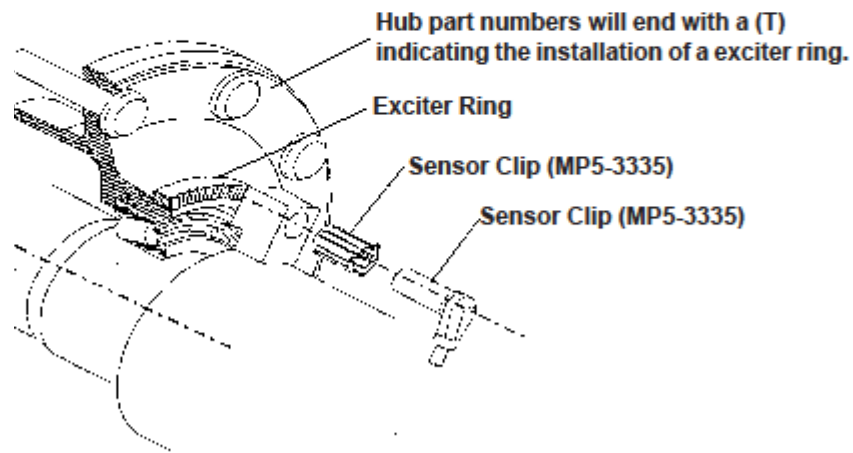

**NOTE:** FFABS can be installed on a variety of trailer configurations capable of controlling 2, 4 or 6 service/spring brake chambers. When the system is installed on a multi-axle trailer, it is important the proper axle is selected for positioning of the ABS wheel end sensors. Several factors are involved in making this decision, including but not limited to, the selected axle should be the one that carries the least load or is most likely to lock first in a hard brake application.

The Full Function ABS Valve was designed as a method of providing a complete trailer braking system combined with skid control in a single package. This valve combines the functions of several separate valves while providing all the valve needs for trailer service and spring brakes.

The FFABS valve has three control sections:

1. Skid control unit that modulates signal pressure to prevent wheel lock up.
2. Relay valve to provide the high flow of air from reservoir to brake chambers required for good brake response.
3. Spring brake control module which incorporates pressure protection, one way check, double check for anti-compounding, and quick release.

The electronic control unit of the FFABS valve receives operating power from the seven-way connector. In the event of a power failure, the system will revert to a typical relay valve system; spring brake control is unaffected by a power failure.

## ADJUSTMENT AND OPERATION OF BRAKES

### Care and Adjustment of Brakes

The trailer brake system will perform safely and efficiently only as long as you maintain it properly and do not abuse it. Trailer brakes should be inspected and adjusted frequently in connection with a Trailer Preventative Maintenance program. Out-of-adjustment brakes can cause increased stopping distance, shorter brake component life, and a greater tendency for the trailer to jackknife.

### Air System and Brake Operation

Proper operation of the brake system requires a firm seal between the air brake glad hands.

1. Inspect the glad hands for rubber washer damage and cracked housing. Inspect the air hoses for cracking and for frayed connections.
2. Keep the air system clean. Primary and emergency air tanks should be drained daily to remove moisture and other contaminants, especially during cold weather operations.
3. Some air valve manufacturers discourage the use of any kind of air line antifreeze. It may result in deterioration of seals in these valves.
4. If you use Teflon tape or other thread sealers to seal threaded connections in your air lines, be careful not to allow pieces of the sealer to enter the air system. They can clog passages into the valves.
5. Keep the air system tight. The air system cannot be charged properly if there are leaks in reservoirs, lines, hoses or valves. Always check the tractor pressure gauge for unusual drops or extended buildup times.
6. Run the tractor engine until the air brake system pressure gauge shows at least 70 psi. Listen for air leaks. With the engine off, check the gauge reading with no brakes applied. The gauge reading loss should not exceed three pounds in one minute.
7. With the engine still off, apply the brakes fully for two minutes. The gauge reading loss should not exceed four pounds per minute.
8. With the engine still off, slowly open a drain cock in an emergency or supply line and allow the pressure to drop gradually.
9. In a system that does not employ spring brake control valves, the relay emergency valve should function and apply the brakes.
10. In a system employing spring brake control valves, spring brakes should function and apply the brakes. Remember that serious air losses are extremely hazardous conditions that are likely to cause accidents or breakdowns.
11. Before entering traffic, check the operation of the trailer brakes to be sure they are in good working order. Try foot pedal, emergency dash control valve (push, pull or flip), and trailer brake lines to assure brake application and release in each instance. Listen for air leaks under each condition.

**WARNING:** Do Not operate this vehicle with any brake defects or with brakes out of adjustment.

### Check Brake Operation

## Tire Inflation and Inspection



### CAUTION:

The law requires that tires are inflated according to the inflation pressure molded on the tire by the tire manufacturer. Tires must be matched with proper compatible rims for safe operation. Replace any tire that has fabric exposed through the tread or sidewall, or that has less than 1/16" tread depth.

Do not over inflate. Check for proper inflation with an accurate gauge when the tires are cold.

Inspect tires for nails and other objects embedded in the rubber, and for stones and other objects lodged between duals.

Examine tires to see that they are free of breaks and other defects. Watch new and retread tires for signs of failure during break-in period. Dual tires on any axle end should have the same diameter.

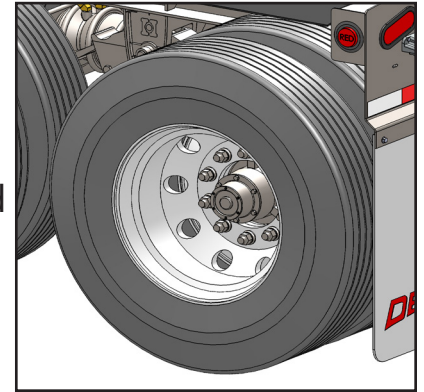

Do not overload the trailer tires. Overloading tires creates a dangerous, unsafe condition that should be avoided.

The total load per tire must not exceed the tire manufacturer's specified load carrying capacity at stated inflation pressures for both tires and rims. Demco Side Dump trailers, as required by the certification regulations of the National Highway Traffic Safety Administration (CFR 49, Part 567), has a Gross Axle Weight Rating plate on each trailer for your information on the running gear capacity.

The GAWR and tire information shown on the vehicle identification plate was applicable at the time the trailer was manufactured. If the tires or other components of the running gear have been changed or altered since the trailer was manufactured, the GAWR may have changed. This should be checked with the Demco factory representative.

## Tire Loads

GVWR: 34091 KG (75000 LB)				
	GAWR	WITH TIRES	RIMS AT	COLD
FRONT	11364 KG (25000 LB)	11R24.5	8.25X24.5	655 KPA (95 PSI) DUAL
INTER	11364 KG (25000 LB)	11R24.5	8.25X24.5	655 KPA (95 PSI) DUAL
REAR	11364 KG (25000 LB)	11R24.5	8.25X24.5	655 KPA (95 PSI) DUAL
THIS VEHICLE CONFORMS TO ALL APPLICABLE U.S. FEDERAL MOTOR VEHICLE SAFETY STANDARDS IN EFFECT ON THE DATE OF MANUFACTURE SHOWN ABOVE.				
SIDE DUMP TRAILER				

**Located on the drivers side near landing gear.**

## HUB PILOT WHEEL INSTALLATION



### CAUTION:

Do not intermix wheel types. Insufficient mounting torque can cause wheel shimmy, resulting in damage to parts and extreme tire tread wear. Excessive mounting torque can cause studs to break and discs to crack in the stud hole area.

Check all parts for damage. Insure that studs, nuts, and mounting faces of hub and wheels are clean and free from grease. Replace any defective parts.

Mount single wheel or inner and outer dual wheels over studs, being careful not to damage stud threads. Draw up nuts alternately in the sequence shown below. Do not tighten them fully, however. This procedure will permit the uniform seating of nuts and insure the even face-to-face contact of wheels and hub.

Tighten nuts fully, using the same alternate sequence. Be sure to tighten wheel nuts only to the torque level recommended below and to maintain them at that level through planned, periodic checks.

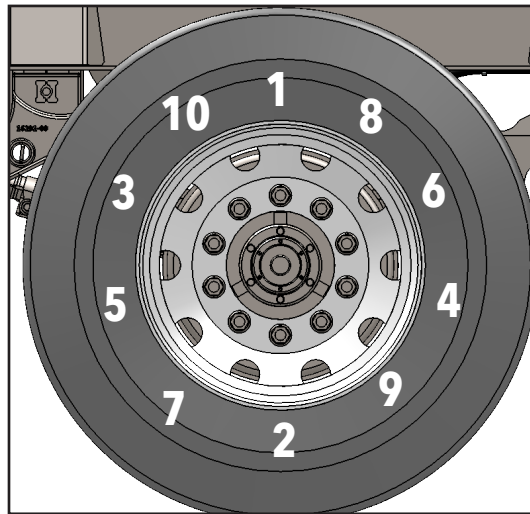

**NOTE:** Lug nuts should be rechecked for proper torque after vehicle has been operated for 50-100 miles, and every 3,000 miles thereafter, as well as during regular maintenance checks.



### CAUTION:

Excessively corroded or cracked rims or rings can be dangerous. Deflate tires prior to the removal of rims or wheels from the vehicle.



### CAUTION:

Insure that replacements are made with the proper sizes and types of rims and rings.

1. Check all metal surfaces thoroughly while making tire inspections, including areas between duals and on inboard side of wheel.

Watch for:

- a. Excessive rust or corrosion buildup
  - b. Cracks in metal
  - c. Bent flanges, resulting from road obstructions
  - d. Deep rim tool marks on rings or in gutter areas
  - e. Loose, missing or damaged nuts or clamps
  - f. Bent or stripped studs
  - g. Damaged or missing rim drive plates
  - h. Mismatched rim parts
2. Pull damaged rims or wheels.
  3. Mark damaged or hazardous areas with chalk so that part will be removed from service.
  4. Replace damaged parts.
  5. Inflate tires only to recommended air pressures.

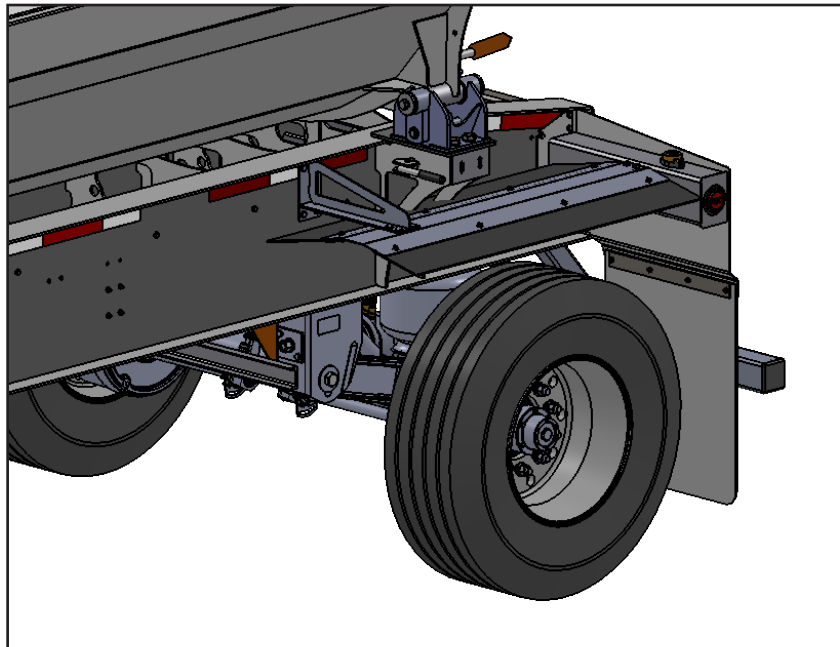

### Axle Inspection



#### **CAUTION:**

Too much oil can damage the wheel bearings.

Check hub gaskets and seals for oil leaks before each trip. Leaking seals can result in ruined wheel bearings and possible failure of the axle-wheel assembly.

Check oil level in hubs before every trip. Add oil when low, only to the level indicated by mark on the hub cap. Use a gear type oil: SAE 140 if temperature is above freezing, SAE 90 if temperature is below freezing, or a multipurpose oil with an SAE range of 85 to 140 for year round conditions.

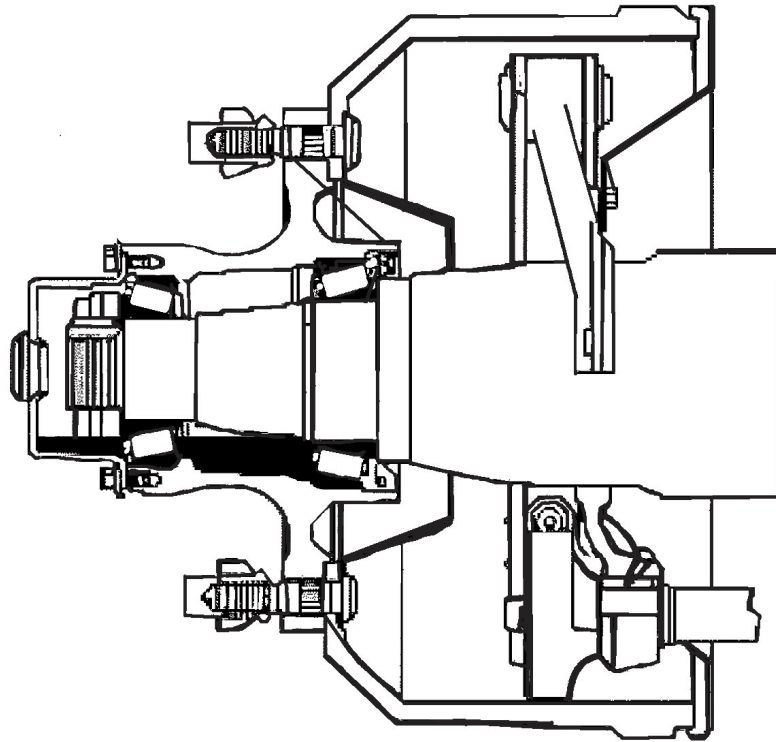

### Axle Alignment

Axle alignment must be checked at regular intervals. If the trailer is not following properly, check the General Troubleshooting section on page 41 or contact your dealer.

**NOTE:** Refer to the SAF-Holland Axle/Suspension online manual for alignment procedures at [www.safholland.us](http://www.safholland.us) or call Holland Technical Assistance at 1-800-876-3929.



The air suspension height is controlled by height control valves that maintains a constant trailer height by pressurizing or exhausting air in the air springs as needed to support the load being carried.

You must build up and maintain your trailer's air pressure higher than 65 psi before operating the trailer. The air protection valve won't operate until you have 65 psi in the system. This valve automatically maintains a safe air brake pressure higher than 65 psi in the event of an air loss due to a failure in the suspension system.

If an air spring failure occurs on one side, it is recommended to completely deflate the suspension and temporarily operate on the air spring's internal rubber bumpers, to allow your trailer to be moved to a shop for repairs.

To deflate or cut off the air pressure to the damaged air spring, disconnect the height control valve actuating levers from their link assemblies and rotate to the vertical down position.

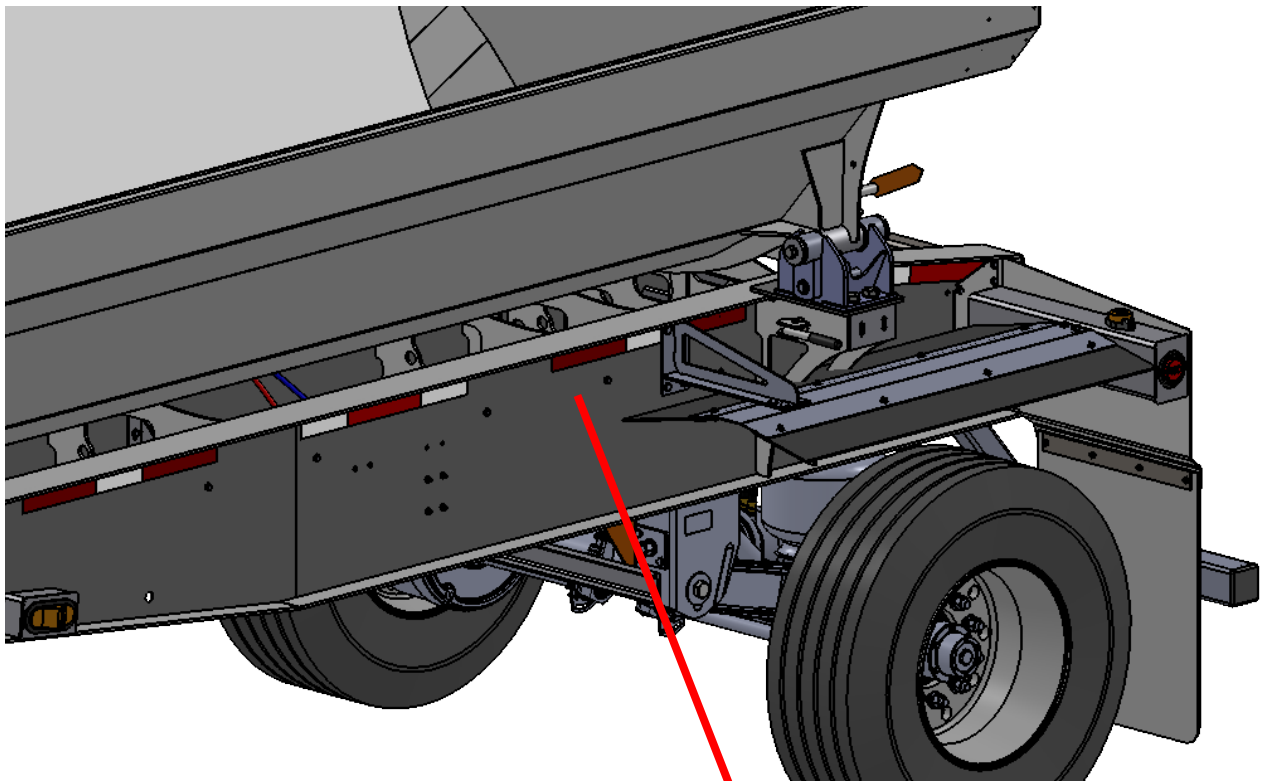

## CBX / CB FIXED FRAME TRAILER AIR SUSPENSION TORQUE SPECIFICATIONS

Torques are with clean, lubricated threads.  
Always apply torque to nut, if possible.

### REQUIRED RE-TORQUING SCHEDULE:

- All fasteners after first three (3) months or 5,000 miles.
- At every routine preventative maintenance.
- At every brake relining.

Fastener Size	Pivot Connection	Shock	Air Spring		SwingAlign
	1-1/8"	3/4"	1/2"	3/4"	1/2"
Torque Ft.-Lbs. (N•m)	450-500 (608-676)	140-175 (190-237)	30-40 (41-54)	40-45 (54-61)	50-60 (68-81)

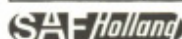

Copyright © 2012 • SAF-HOLLAND, Inc.

www.safholland.us

XL-48436 Rev. E

**AXLE AND ALIGNMENT**

<b>MALFUNCTION</b>	<b>PROBABLE CAUSE</b>	<b>CORRECTIVE ACTION</b>
Semi-trailer swerves.	Accidental damage to axle from striking obstruction	Replace axle.
	Damage to axle from overloading	Replace axle.
	Loose nuts holding shackle box	Tighten or replace shackle box or shackle box liners.
Hard pulling.	Dragging brakes	Adjust brakes.
	Improper wheel bearing adjustment	Adjust wheel bearings.
	Bent axle	Replace axle.
	Dragging Axle, lost U-bolt	Align axles and secure.
Excessively worn, scuffed, or cupped tires.	Improper tire pressure	Inflate tires to proper pressure.
	Loose wheels	Tighten cap nuts.
	Loose wheel bearings	Adjust wheel bearings.
	Bent rim or wheel	Replace wheel.
	Bent axle	Replace axle.
	Axles out of alignment	Align axles.
<b>For Additional FAQs on the Axles</b>		<b>Please go online to <a href="http://www.safholland.us">www.safholland.us</a> or call Holland Technical Assistance at 1-800-876-3929</b>

**BRAKES AND AIR SYSTEM**

<b>MALFUNCTION</b>	<b>PROBABLE CAUSE</b>	<b>CORRECTIVE ACTION</b>
Brakes erratic or unequal.	Improper lubricant or grease inside brake drum or outside of wheel	Clean and lubricate.
	Loose hub cap	Tighten hub cap.
	Defective oil seals	Replace defective oil seals.
Overheated brake drum.	Broken or weak brake shoe return spring	Replace return spring.
	Broken brake lining	Replace brake shoe assembly.
	Dragging brake shoe assembly	Adjust brake shoe assembly.
	Bent axle spindle	Replace axle.
Insufficient brakes.	Improper brake adjustment on worn brake linings	Adjust brakes or replace brake shoe assemblies as necessary.
	Improper slack adjuster adjustment	Adjust slack adjuster.
	Air leakage in brake system	Examine for air leaks in brake system. Replace components that are found defective.
	Low air pressure	Check air pressure gauge in towing vehicle cab. Pressure must not be below 80 psi.
	Restriction in air hose or lines	Look for dented or kinked air lines. Examine air hoses to make sure none are pinched between other components on the same trailer.
Slow brake application or slow release.	Maximum brake chamber pushrod travel	Adjust slack adjuster and adjust brakes as necessary.
	Weak brake shoe return spring	Check brake shoe return spring replace if found to be weak.
Noisy brakes.	Lining or rivets loose	Replace brake drum assembly.
	Road grit, rust or metal particles in brake drum or lining	Clean brake drum and lining. Replace brake shoe assembly if grit or metal particles are embedded in the lining.
	Brake drum out of round or scored	Repair or replace brake drum.

**BRAKES AND AIR SYSTEM (CONTIN.)**

<b>MALFUNCTION</b>	<b>PROBABLE CAUSE</b>	<b>CORRECTIVE ACTION</b>
Grabbing brakes or wheels.	Lubricant on brake lining	Inspect for lubricant on brake lining. Replace brake shoe assembly if lubricant on lining is evident.
	Loose brake lining	Inspect brake lining for sheared or worn rivets or bolts. Replace defective brake shoe assembly.
	Distorted brake lining	Replace brake shoe assembly.
	Loose or worn wheel bearings	Adjust wheel bearings. If adjustment of wheel bearings does not correct the condition, replace bearings.
Not holding air pressure.	Excessive leakage in relay-emergency valve, and exhausts port	Replace relay-emergency valve.
	Air leakage at line connectors	Tighten connectors until air leakage disappears. If air leakage persists, replace defective connectors and/or air lines.
	Leakage at service or emergency line couplings	Couplings are improperly connected or packing ring gasket in hose coupling is defective. Connect couplings properly or replace packing ring gasket in hose couplings.
	Air leakage at service or emergency air hose coupling when towing vehicle service air hose is disconnected	Replace relay-emergency valve.
No brakes.	Source of air supply shut off at towing vehicle	Open air line valves at rear of towing vehicle.
	Air brake hose between semi-trailer and towing vehicle not properly coupled	Examine air brake hose to make sure hoses marked SERVICE and EMERGENCY are properly connected to the semi-trailer and towing vehicle.
	Air reservoir drain cock open	Check air reservoir drain cocks on both semi-trailer and towing vehicle.
	Air leakage from RE-6 valve	Test for air leaks by applying soap suds to cover plate, cover plate vent, and exhaust port. Replace with new unit if any leaks are present.
	Air leakage in brake system	Examine all air hoses, lines, and connecting components in the brake system for air leaks. Replace any component that are found to be defective.
	Low air pressure	Check air pressure gauge in towing vehicle. Pressure must not be below 80 psi.
	Defective relay-emergency valve	Replace defective valve.
	Brake air chamber inoperative	Check for punctured diaphragm.
	Brakes need adjustment	Adjust brakes.
<b>For Additional FAQs on the FFABS</b>		<b>Call Haldex Technical Department at 1-800-643-2374.</b>

**Haldex ABS Diagnostic Flash Codes**

<b>Item</b>	<b>Flash Count</b>	<b>Actual Fault</b>
System OK	Lamp Stays On	07
Sensor 1A	1 Flash	01, 11, 21
Sensor 1B	2 Flashes	02, 12, 22
Sensor 2A	3 Flashes	03, 13, 23
Sensor 2B	4 Flashes	04, 14, 24
Sensor 3A	5 Flashes	05, 15, 25
Sensor 3B	6 Flashes	06, 16, 26
Red Valve	7 Flashes	41, 61, 67, 71, 77, 81, 87
Blue Valve	8 Flashes	42, 62, 58, 72, 78, 82, 88
Yellow Valve	9 Flashes	43, 63, 69, 73, 79, 83, 89
Low Voltage	10 Flashes	90
ECU Failure	11 Flashes	93, 99, E-Codes

**ELECTRICAL SYSTEM**

<b>MALFUNCTION</b>	<b>PROBABLE CAUSE</b>	<b>CORRECTIVE ACTION</b>
All lights fail to light.	Inter-vehicular cable not properly plugged into receptacles on semi-trailer and towing vehicle	Pull plugs out and reinsert them. Be sure plugs seat properly.
	Light switch on towing vehicle is malfunctioning	Check light switch.
	No current from towing vehicle	Check circuit breaker and wiring on towing vehicle.
	Short circuit in wiring	Check wiring for bare spots in insulation.
	Dirty or corroded contacts in receptacle or on plug of inter-vehicular cable	Clean receptacle and plug.
	Dirty or corroded contacts in connectors of semi-trailer wiring	Clean corroded contacts in connectors.
Lights burn dim or flicker.	Loose, dirty, or corroded terminals	Clean and tighten terminals.
	Poor or loose ground	Clean and tighten terminals on short (ground) cable.
	Defective lamps	Replace defective lamps.
	Dirty or corroded lamp socket or contact in receptacle, or on plug of inter-vehicular cable	Clean or replace lamp socket, receptacle, or plug.
Individual lamps do not light.	Burned out lamp	Replace lamp.
	Broken or loose connection	Tighten, repair, or replace broken connections. Clean poor or dirty connections.
	Damaged light assembly	Repair or replace light assembly.
	Dirty or corroded lamp socket	Remove lamp and clean contacts.
	Dirty or corroded contact in receptacle or on plug of inter-vehicular cable	Clean receptacle and plug.

**HYDRAULIC SYSTEM**

<b>MALFUNCTION</b>	<b>PROBABLE CAUSE</b>	<b>CORRECTIVE ACTION</b>
Tub will not dump.	Hoses not connected to power unit	Clean hydraulic coupler and connect to trailer.
	Power unit malfunction	Check power unit pressure and flow rate.
	Ruptured line or loose fitting	Check for hydraulic leaks - replace hydraulic hose and/or fitting.
	Hydraulic cylinder	Replace cylinder packing.
	Proportional valve	Check pressure at both cylinders for equal pressure.
	Double relief valve	Adjust high-pressure relief cartridge.
Tub dumping slowly.	Dirt in relief valve	Disassemble valve. Clean with diesel fuel or kerosene, or replace cartridge.
	Chattering noise in relief valve	Dirty valve or pressure set too low and by-passing. Check pressure setting.
	Power unit hydraulic system	Check pressure and flow rate on power unit.

## HUBS, BEARINGS, WHEELS, AND TIRES

MALFUNCTION	PROBABLE CAUSE	CORRECTIVE ACTION
Noise.	Brake shoes drag on drums	Adjust brakes.
	Brake shoes out of round	Repair or replace brake drum.
	Broken brake shoe return spring	Replace broken return spring.
	Loose wheel stud nuts	Tighten loose wheel nuts.
	Damaged wheel bearings	Replaced damaged wheel bearings.
	Wheel bearings not properly adjusted	Adjust wheel bearings.
	Obstruction between duals or in tread	Remove obstruction.
	Damaged wheels and/or hubs	Replace damaged wheels and/or hubs.
Wobbly wheels.	Loose cap nuts	Tighten or replace cap nuts.
	Improperly-adjusted wheel bearings	Adjust wheel bearings.
	Bent or damaged wheel	Replace damaged wheels.
	Bent axle spindle	Replace axle.
Overheated hubs.	Lack of wheel bearing lubricant	Lubricate wheel bearings.
	Wheel bearings improperly-adjusted	Adjust wheel bearings.
	Damaged bearing or cup	Replace damaged bearing or cup.
	Damaged hub	Replace damaged hub.
	Bent axle spindle	Replace axle.
	Overloading or unbalanced load distribution	Check load weights hauled and keep within rated gross capacity, or arrange load evenly.
Air leakage from tires.	Valve core loose or damaged	Tighten or replace valve core.
	Punctured tube	Repair or replace tube.
	Damaged bearing or cup	Replace damaged bearing or cup.
Undue wear of any or all tires.	Incorrect tire inflation	Inflate tire to proper pressure. Tighten valve caps finger tight.
	Overloading	Check load weights hauled and keep within rated gross capacity.
	Brake action too severe	Check and adjust brakes
	Tires not properly inflated	With tire properly inflated, check overall circumference of tires. The difference in overall circumference must not exceed the 3/4 inch limit. Remove wheel and tire assembly and match tires.

**TARP (Roll-Rite Optional Part)**

<b>MALFUNCTION</b>	<b>PROBABLE CAUSE</b>	<b>CORRECTIVE ACTION</b>
The motor is not working (Roll-Rite Tarp Brand)	Power Supply Issue	Disconnect both power wires from the motor. Using jumper cables and a fully charged spare battery, momentarily supply power to the motor terminals, first one direction, and then the other. If the motor does not run, call Roll-Rite Customer Service at 1-800-297-9905. If the motor runs when connected to the spare battery, then the motor is OK. Reconnect original power wires to the motor.
	The wiring and circuit breaker between the battery and the relay	Use a test light or a voltage meter to verify that the BATT+ and BATT- terminals on the relay are properly connected. If not, check the wiring and circuit breaker between the battery and the relay for problems, such as loose terminals and/or worn, broken, or pinched spots on the wire.
	The relay not clicking with T1 & T2 attached to BATT+	Use a small piece of jumper wire, momentarily connect first the T1 terminal and then the T2 terminal to BATT+. If you do not hear the relay click, call the Roll-Rite Customer Service at 1-800-297-9905.
	The wiring between the relay and the motor	Use a small piece of jumper wire, momentarily connect first the T1 terminal and then the T2 terminal to BATT+. If you hear clicking but the motor does not operate, check the wiring between the relay and the motor.
	The wiring between the switch and the relay	Assuming that you are using a standard SPST switch similar to the one that was shipped with the relay, (if you are using something else, you may have to adjust the procedure accordingly) use a small piece of jumper wire to momentarily connect the center terminal (common) first to one of the outer terminals. Then repeat for the other outer terminal. If the motor does not operate during this test, check the wiring between the switch and the relay.
	The Switch	Assuming that you are using a standard SPST switch similar to the one that was shipped with the relay, (if using something else, adjust the procedure accordingly) use a small piece of jumper wire to momentarily connect the center terminal (common) first to one of the outer terminals. Then repeat for the other outer terminal. If the motor operates during this test, then the problem is in the switch, call Roll-Rite Customer Service at 1-800-297-9905.
<b>For Additional FAQs on Roll-Rite Tarps</b>		<b>Please go online to <a href="http://www.RollRite.com">www.RollRite.com</a> and then to the Customer Support section or call Customer Support at 1-800-279-9905</b>

**TARP (Aero Optional Part)**

<b>MALFUNCTION</b>	<b>PROBABLE CAUSE</b>	<b>CORRECTIVE ACTION</b>
Cover only partially deployed and CANNOT get to covered position (Aero Tarp Brand)	Power loss or failure	<p><b>WARNING!</b> The Aero Side Kick 2 cover system operates under extreme spring tension to drive the swing-arms. To reduce the possibility of injury, the swing arms must be secured before servicing the system. The following instructions are for a temporary field repair. Contact Aero Industries or your Side Kick dealer for standard repairs.</p> <p>Step 1: Secure Swing Arms. Attach come-alongs to the swing-arms, NOT the roll bar. 1) See Figure 1. Attach one end of the come-along to the front swing arm (A), near the motor housing. Attach the other end of the come along to the trailer on the side the tarp is anchored (B). 2) Attach another come-along between the rear swing-arm (C) and the trailer (D). 3) Tighten the come-alongs equally until the tarp becomes slack and the swing-arms are secure.</p> <p>Step 2: Disengage the Motor 1) Once the swing-arms are secure, remove 3 hex head cap screws from front roll-up bar adaptor attached to front roll tube and slide front swing arm (with front roll-up bar adaptor) out of front of roll-up bar and remove rear swing arm by removing outside 1-1/4" lock collar from rear roll-up bar adaptor and sliding arm off back of roll tube.</p> <p>Step 3: Complete the Covering Process <b>WARNING!</b> The come-alongs are now retaining the force of the swing-arm spring tension. Use great care and make sure you understand how the come-along operates before adjusting. 1) To cover the trailer, slowly and equally adjust the come-alongs until the roll tube is resting in the supports on the driver-side of the trailer. Remove or secure the come-alongs before transport. <b>WARNING!</b> The tarp must be in the fully unrolled position and not under the latch plate, before any service/repair work can be performed.</p>
<b>For Additional FAQs on Aero Tarps</b>		<b>Please go online to <a href="http://www.aeroindustries.com">www.aeroindustries.com</a> or call Customer Support at 1-800-535-9545</b>

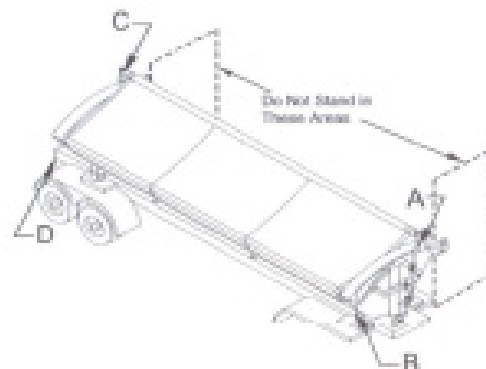

**Figure 1**

**DEMCO**

4010 320th St., Boyden, IA. 51234

Phone: (712) 725-2311

Fax: (712) 725-2380

Toll Free: 1-800-54DEMCO (1-800-543-3626)

**Demco warranty policies, operator manuals, and product registration  
can be found online:**

**[www.demco-products.com](http://www.demco-products.com)**